

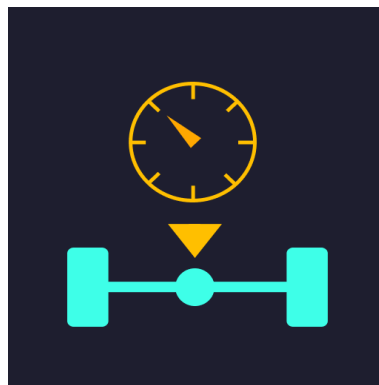

## **AXLE LOAD MONITOR**



**Mobile application**

**USER MANUAL**

**Version 1.1**



---

**TECHNOTON**  
ADVANCED VEHICLE TELEMATICS

## Contents

Contents .....	2
Revision history .....	3
Structure of external links .....	4
Terms and Definitions .....	5
Introduction .....	7
1 Purpose of application and areas of its employment .....	8
2 Functionality .....	9
3 Software/hardware requirements.....	10
4 Procedure for the application installation on the Android device .....	11
5 Subscription procedure .....	13
6 Use of application .....	15
6.1 Establishment of connection between the sensor and the mobile device .....	15
6.2 Interface of application .....	17
6.3 Operations with the sensor profile .....	19
6.4 Calibration of measuring system .....	20
6.5 Adaptation of axle load indications for a specific Vehicle.....	23
6.6 Configuring Events detection function and displaying recorded Events .....	26
6.7 Monitoring and recording readings .....	28
6.8 Malfunction diagnostics.....	30
7 Procedure for deleting the application from Android device.....	31
Contacts .....	32
Annex A Videography .....	33

## Revision history

<b>Version</b>	<b>Date</b>	<b>Editor</b>	<b>Description of changes</b>
1.0	10.2021	OD	Basic version.
1.1	05.2025	OD	Support for the Axle Load Monitor mobile application has been discontinued for iOS devices.

## Structure of external links

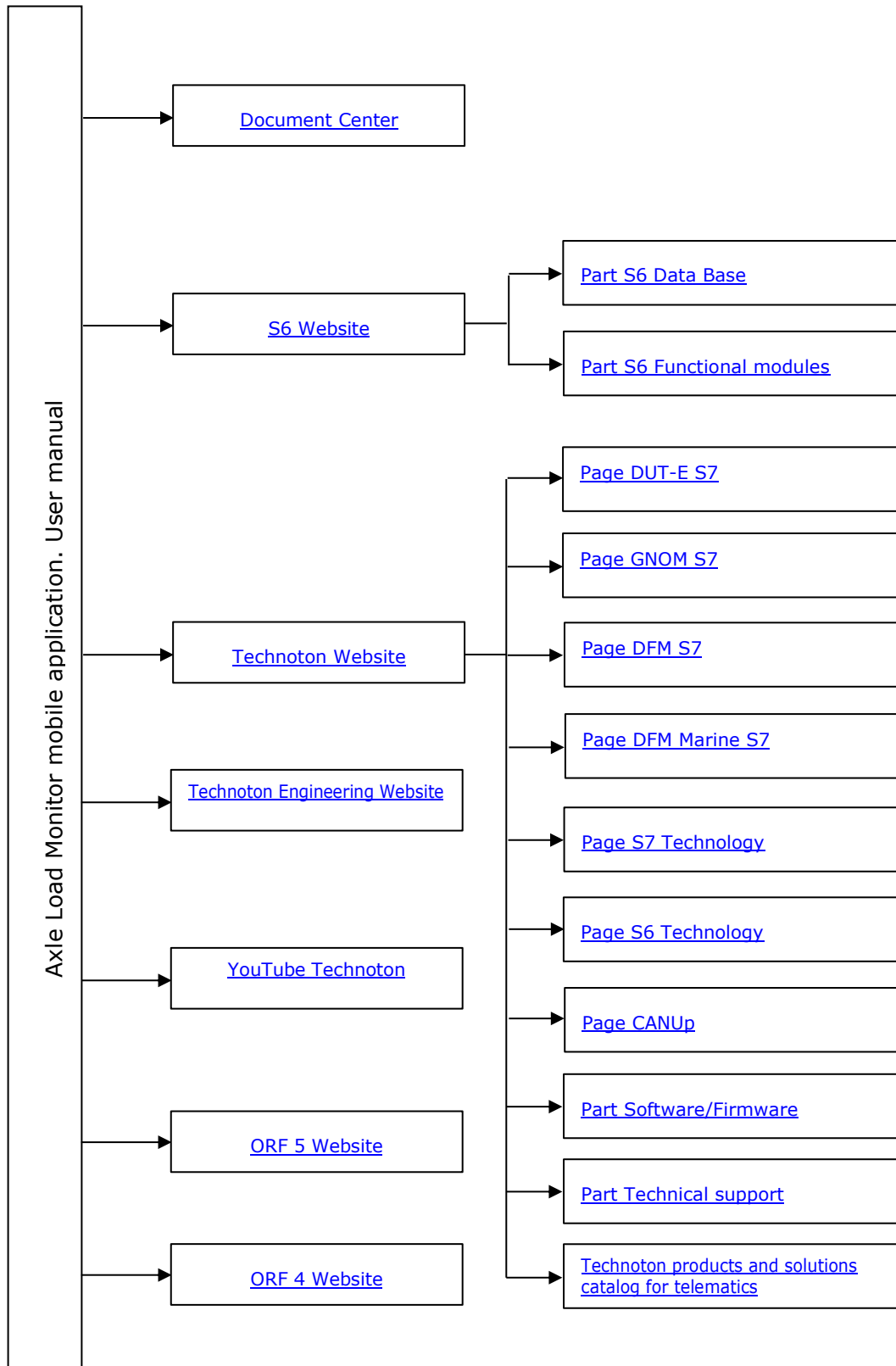

## Terms and Definitions

**S7** — Technology designed for wireless collection of data from unattended sensors in systems of industrial and automobile Telematics. S7 Technology is recommended for use in facilities where wiring is impossible or hard to install.



S7 Technology implements Bluetooth 4.X Low Energy (BLE) as a communication channel. S7 Technology provides ultra-low power consumption and a long period of independent operation for smart sensors and other IoT devices.

On the application level, S7 Technology is fully compatible with [S6 Technology](#) which uses cabling.

Advantages of S7 Technology:

- Simple design of data transmission protocol;
- Low power consumption, a potential for fully independent operation of sensors for several years;
- Option of data collection by several data recipients at one time.

[GNOM\\_DP\\_S7](#) and [GNOM\\_DDE\\_S7](#) wireless axle load sensors are designed based on S7 Technology.

**S6** is the Technology of combining smart sensors and other IoT devices within one wire network for monitoring of complex stationary and mobile objects: vehicles, locomotives, smart homes, technological equipment etc. The Technology is based and expands SAE j1939 automotive standards.



Information on cabling system, service adapter and S6 software refer to [CAN j1939/S6 Operation manual](#).

**PGN** (Parameter Group Number) — is a combined group of S6 parameters, which has common name and number. Functional modules (FM) of the Unit can have input/output PGNs and setup PGNs.

**SPN** (Suspect Parameter Number) — informational unit of S6. Each SPN has determined name, number, extension, data type and numerical value. The following types of SPN exist: Parameters, Counters, Events. SPN can have a qualifier which allows qualification of parameter's value (e.g. – Onboard power supply limit/Minimum).

**Onboard reports** (the Reports) — information about vehicle which is returned to a user of Telematics system in accordance with inputted criteria. The Reports are generated by a terminal unit both periodically (Periodic reports) and on Event occurrence (Event report).

**Parameter** — time-varying or space characteristic of the Vehicle (SPN value). For example, speed, fuel volume in the tank, hourly fuel consumption, coordinates. Parameter is usually displayed in the form of graph, or averaged data.

**Server** (AVL Server) — hardware-software complex of Telematics service ORF 4, used for processing and storage of Operational data, formation and transmission of Analytical reports through Internet by request of [ORF 4](#) / [ORF 5](#) users.

**Event** — relatively rare and sudden change in SPN. Sharp increase in axle load is "Load" Event. This Event may have one or more characteristics. So, the "Load" Event has the following characteristics: date/time, "axle load at the beginning of loading", "axle load at the end of loading", "cargo weight" etc. When the Event occurs, a terminal unit registers the time of occurrence, which is later mentioned in a report on the Event. Thus, the Event is always attached to exact time and place of occurrence.

**Counter** — cumulative numerical characteristics of Parameter. Counter is represented by a number, which can only grow in time. Examples of Counters: fuel consumption, engine operation time, total distance and other.

**Telematics terminal** (Tracking device, Telematics unit) is a unit of Telematics system used for reading the signals of Vehicle standard and additional sensors, getting location data and transmitting the data to the Server.

**Telematics system** — complex solution for vehicle monitoring in real time and trip analysis. The main monitored characteristics of the vehicle: Route, Fuel consumption, Working time, technical integrity, Safety. It includes On-board report, Communication channels, Telematics service [ORF 4](#) / [ORF 5](#).

**Vehicle** an object controlled within Telematics system. Usually Vehicle means a truck, tractor or bus, sometimes a locomotive or river boat. From Telematics system point of view, stationary objects are also considered to be vehicles: diesel gensets, stationary tanks, boilers/burners.

**Unit** is an element of vehicle on-board equipment compatible with S6 bus, which uses [S6 Technology](#) or [S7 Technology](#).

## **Information regarding the change in the usage policy of mobile applications for monitoring readings from wireless S7 Technology Units**

As of **April 1, 2024**, the **subscription fee** for all Technoton mobile applications **has been abolished**:

- Fuel Tanks Monitor
- Fuel Rate Monitor
- Axle Load Monitor

All these applications are available for **free** installation on your mobile devices and full use of their features.

**Any information related to the subscription fees for mobile applications provided in this document below is now outdated.**

## Introduction

Recommendations and rules set out in this User Manual apply to the **Axle Load Monitor mobile application** (further on — application) developed by [Technoton](#) company.

This document contains the purpose, basic features, a description of the application user interface, as well as the procedure of its use for the dedicated purpose.

**Axle Load Monitor — is a powerful software tool for mobile devices which serves for monitoring indications of GNOM DP S7 and GNOM DDE S7 next generation wireless axle load sensors.**

Distinctive features of Axle Load Monitor application:

- analytical processing of data arrays received via Bluetooth Low Energy (BLE) channel from wireless axle load sensors by means of S7 Technology;
- real-time monitoring axle load indications of road trains on the display of a smartphone / tablet — total and separately for each axle (up to 11 axles);
- automatic notification of exceeding the admissible axle load;
- remote pressure check in the compressed air system during vehicles examination\*;
- convenient monitoring cargo weight precisely on the Vehicle load/unload site;
- function of digital self-diagnostics for sensor quality control;
- convenient intuitive interface, inexpensive subscription;
- high quality [technical support](#) and [documentation](#).



**ATTENTION:** While using the application, we recommend to follow the instructions provided in this User manual.

For proper use of the application together with GNOM DP S7 and GNOM DDE S7 sensors, we recommend to undergo [corporate training](#).



**ATTENTION:** Technoton company reserves the right to modify the application specifications that do not lead to deterioration of the consumer qualities, without prior customer notice.

---

\* When using GNOM DDE S7.

# 1 Purpose of application and areas of its employment

**Axle Load Monitor application is designed to load indications of [GNOM\\_DP\\_S7](#) and [GNOM\\_DDE\\_S7](#) wireless axle load sensors on the display of a smartphone/tablet by means of [S7 Technology](#).**

**Application area:** Visual monitoring axle load (cargo weight) of mobile equipment exactly on site where they operate (see figure 1).

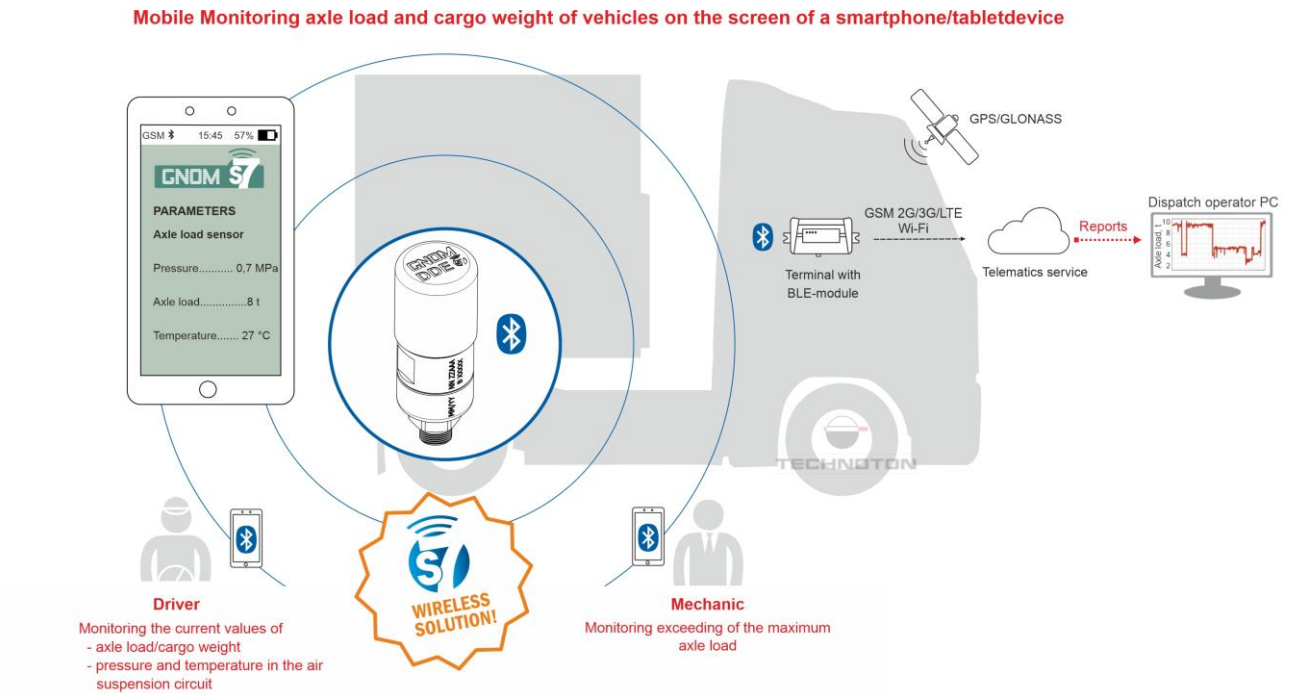

Figure 1 — Example of area of application of Axle Load Monitor application

## 2 Functionality

The functionality of Axle Load Monitor application enables to exercise:

- monitoring the sensor ID data, including specifying of:
  - model;
  - serial number\*;
  - mode of operation, depending on BLE-module status\*;
  - firmware version;
  - MAC-addresses of BLE-module\*;
  - received signal level (RSSI) and the time of the latest message reception\*;
- real-time monitoring of:
  - axle load;
  - compressed air pressure in the compressed air system (in case of employing GNOM DDE S7)\*;
  - angular deviation of pivot lever (in case of employing GNOM DP S7)\*;
  - ambient temperature\*;
- creation of the calibration table of the measuring system and its saving in the memory of the mobile device;
- selection of diagrams with layouts of monitored axles for:
  - tractor truck;
  - trailers (up to 5 pcs.);
- entering thresholds for "Maximal" and "Overload" modes of loading;
- registration and receiving notifications of "Overload" [Event](#);
- monitoring axle load indications of up to 11 pcs. of GNOM S7 sensors of any models, with displaying axle load values — total and separately for each axle;
- monitoring presence/absence of sensor active malfunctions \*;
- registration (logging) of current readings of:
  - axle load;
  - compressed air pressure in the compressed air system (in case of employing GNOM DDE S7);
  - angular deviation of pivot lever (in case of employing GNOM DP S7);
  - ambient temperature;
- carrying out operations with the sensor profile;
- selection between the metric / American systems of units of measurement for displaying indications\*;
- choosing Russian/English language of the application interface\*.

---

\* The feature is accessible without subscription to the application.

## 3 Software/hardware requirements

- 1) You may use the following mobile devices for work with Axle Load Monitor application:
  - smartphone or tablet of any producer based on Android 5.0 and higher operating system (further on — Android device).
- 2) The mobile device you are using should have:
  - Bluetooth, version not lower than 4.0;
  - Internet access.
- 3) [GNOM DP S7](#) / [GNOM DDE S7](#) readings can be loaded on the display of a mobile device **only after the sensor activation**. A wireless sensor is active and ready for work with the application from the moment "Operating" / "Manufacturing" mode of operation is activated in its BLE-module.

You can study the detailed description of modes of operation of wireless axle load sensors, depending on their BLE-module status, as well as the procedure of their activation, in [GNOM S7 operation manual](#).

### **IMPORTANT:**



1) To eliminate connection disruption between a wireless sensor and a smartphone/tablet during your work with the application, you are to make sure there are no sources of electromagnetic interference close to your workplace (radio telephones, video signal transmission units and other wireless devices operating within 2.4 or 5.0 GHz frequency bands, as well as running electric motors, powerful transformers and switching equipment, welding equipment, high-voltage lines etc).

2) The maximally allowed distance between a sensor and a smartphone/tablet depends on the quality of the Bluetooth module of a specific mobile device.

To assure the stable data transmission, it is recommended that this distance should not exceed 20 m.

## 4 Procedure for the application installation on the Android device

1) Open **Google Play** applications store and enter the search request "Technoton":

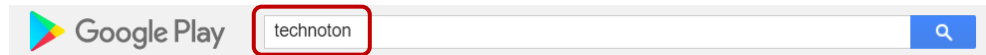

2) Select the line of Axle Load Monitor application from the list of [Technoton](#) mobile applications and press **Install** button:

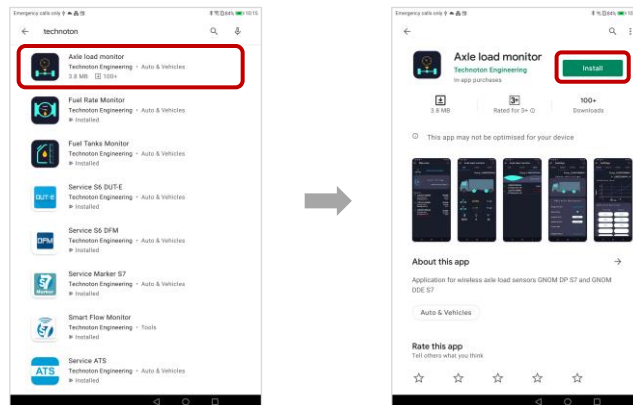

3) As soon as the installation is completed, start the application by pressing **Open** button and confirm the requested authorizations (activation of Bluetooth, access to geolocation, access to files) that are needed for running the application:

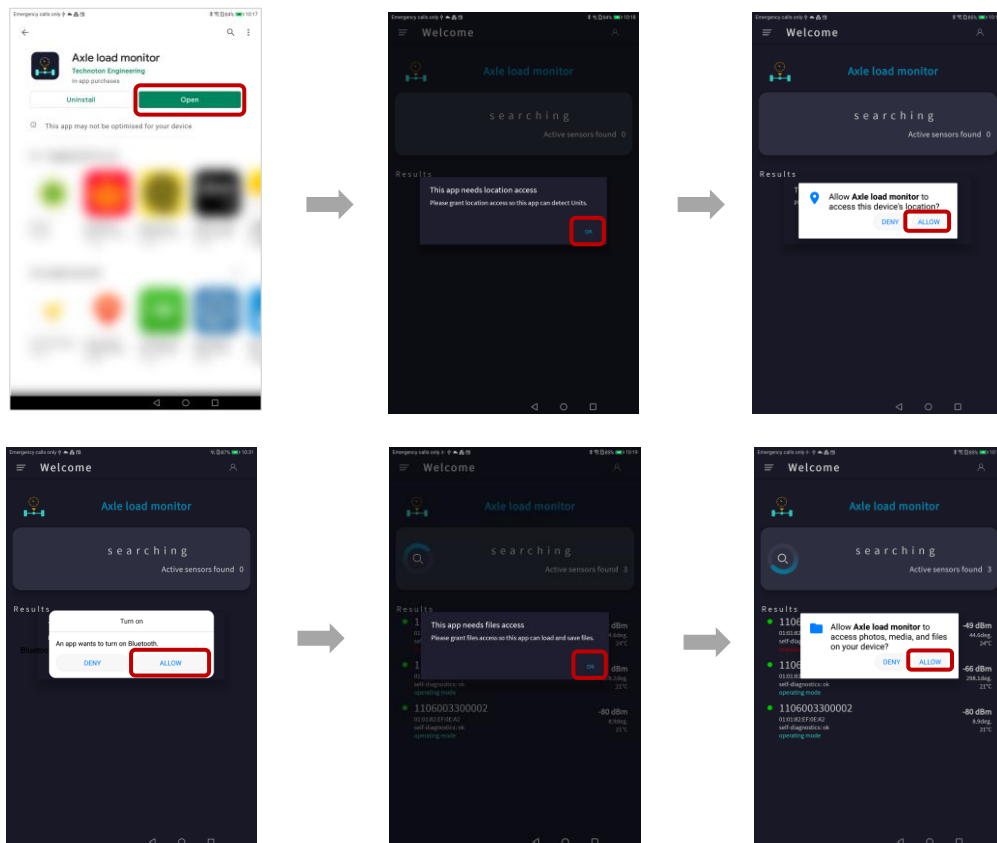

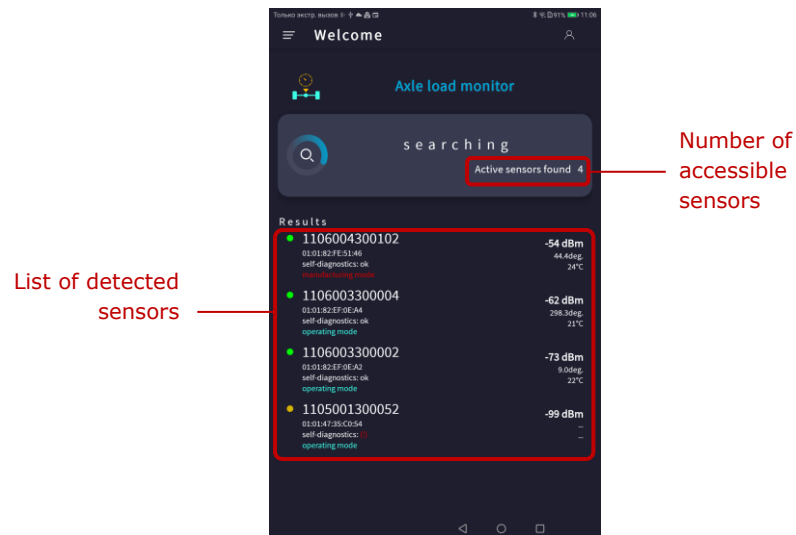

4) After confirmation of all requested authorizations, the application is ready for work and it will automatically search and detect accessible sensors:



## 5 Subscription procedure



Only ID data check and serviceability check of detected active sensors are available in Axle Load Monitor application without subscription (see 6.1).

For full-size use of the powerful application functionality (see 2), get the paid subscription with 10 days' test period.

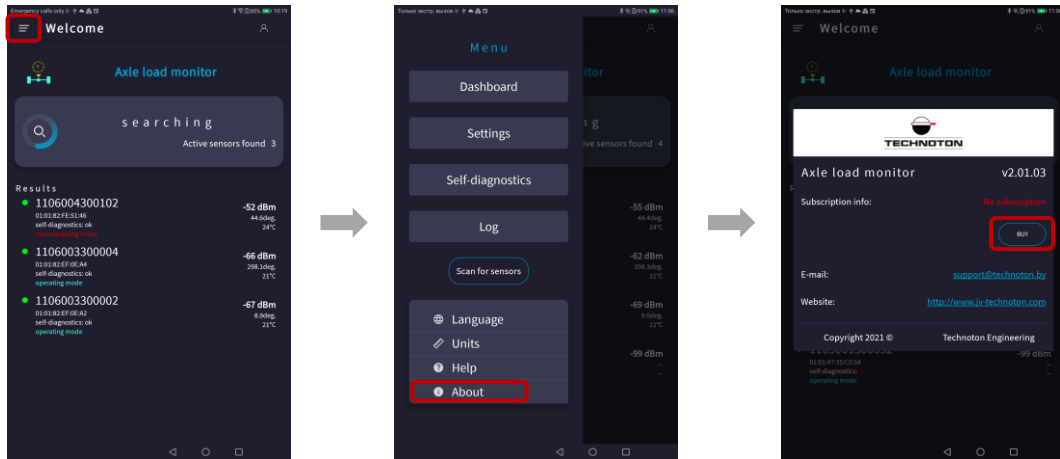
1) Press  icon on the screen to open the main menu; then press  button in  submenu.



Note — In case the installed application detects active sensors, to start subscribing, you may press the line of any sensor from their list. The following operations are similar to the described above.

2) In **Subscriptions** window select the required period of subscription to the application and press the respective  button. In the window of Google Play service that opens, the start of the subscription period and the test period for the application are indicated. By pressing  button, make a payment, after which you are considered subscribed to the application.

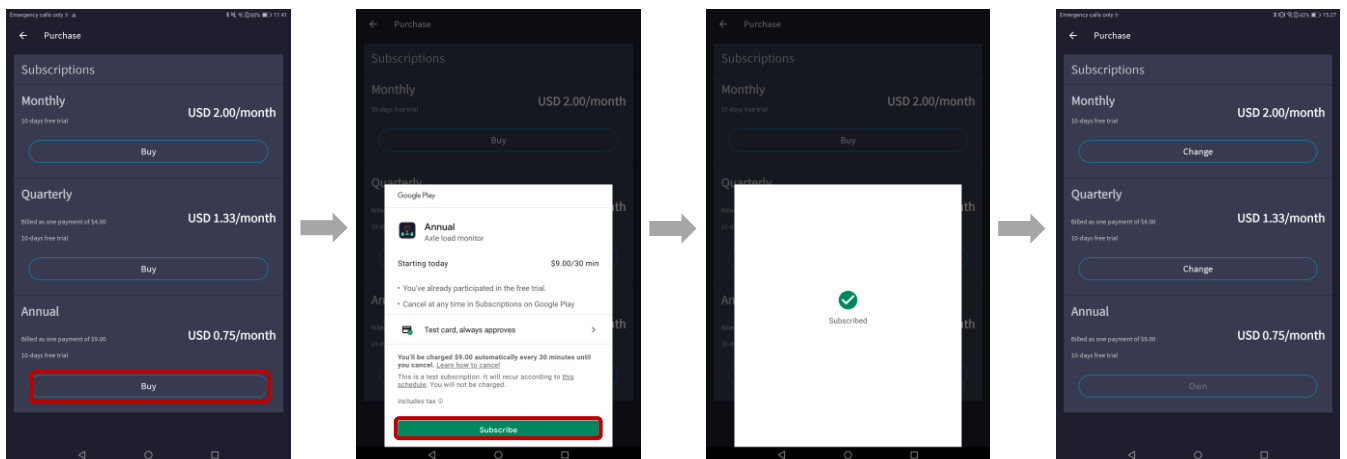

3) When you open **About** submenu next time, some of its elements will assume a different view:

- Instead of **No subscription** status, **Active subscription** link will appear. Using it, you may open **Manage subscription** of Google Play service. You are to open the application in this window, before the indicated test period expires, to confirm your subscription. Here, you may also update the method of payment or cancel the subscription.
- Instead of **BUY** button, **CHANGE** will appear which serves to open the window to choose the subscription period. In this window, you can change the initially specified period of subscription.

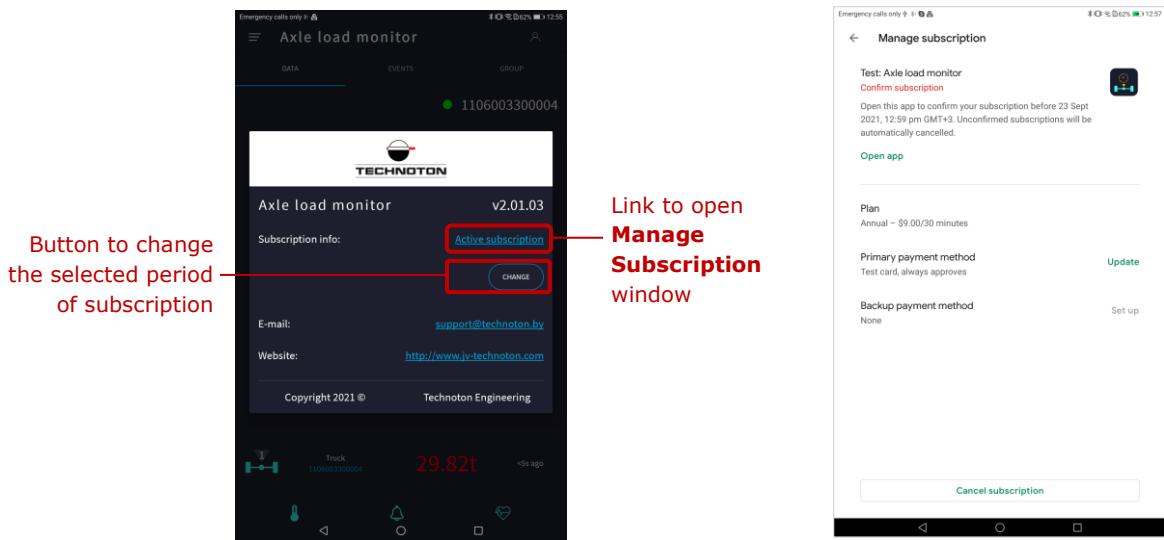

## 6 Use of application

### 6.1 Establishment of connection between the sensor and the mobile device



**WARNING:** All settings specified in Axle Load Monitor application are not stored in the sensor, but saved only in the memory of the mobile device used, in the profile file of a specific sensor (see [6.3](#)).

Start Axle Load Monitor application by clicking on  icon in the main menu of the mobile device.

The application will offer to activate Bluetooth (in case it was off) and will open **Welcome** screen. This screen always opens, whenever the application is loaded; this is the starting point during your work with wireless axle load sensors. It contains **Tools bar** (see [6.2](#)) to perform operations, as well as the search area for search of active sensors.

Monitoring data from [GNOM DP S7](#) / [GNOM DDE S7](#) is possible from the moment the sensor BLE-module is activated (activation of "Operating"/"Manufacturing" mode of operation).

Each sensor detected is automatically entered into the list of accessible devices by the application (**Results** list), with displaying the following data (see figure 2):





- serial number **(1)**;
- signal of the time the latest message was received **(2)** (see table 1);
- MAC-address of the BLE-module **(3)**;
- information on presence/absence of active malfunctions **(4)**;
- mode of operation, depending on the status of the BLE-module **(5)**;
- received signal strength indicator (RSSI) **(6)**;
- indications of: compressed air pressure in the compressed air system (during work with GNOM DDE S7) or of pivot lever angular deviation (during work with GNOM DP S7) **(7)**;
- ambient temperature **(8)**.

Monitoring the data listed above is available for the user without subscription to the application.

To establish connection with the required sensor from the list of accessible devices, press the line with its serial number.

During operation, signals of indicator time of receiving last message from the sensor on the mobile device should be displayed in Axle Load Monitor app (see table 1).

Table 1 – Values of signals of time indicator of receiving last message from sensor

Signal type	Signal color	Signal values
	Green	Less than 20 s passed after receiving last message from the sensor
	Yellow	(20...40) s passed after receiving last message from the sensor
	Orange	(40...60) s passed after receiving last message from the sensor
	Red	More than 60 s passed after receiving last message from the sensor

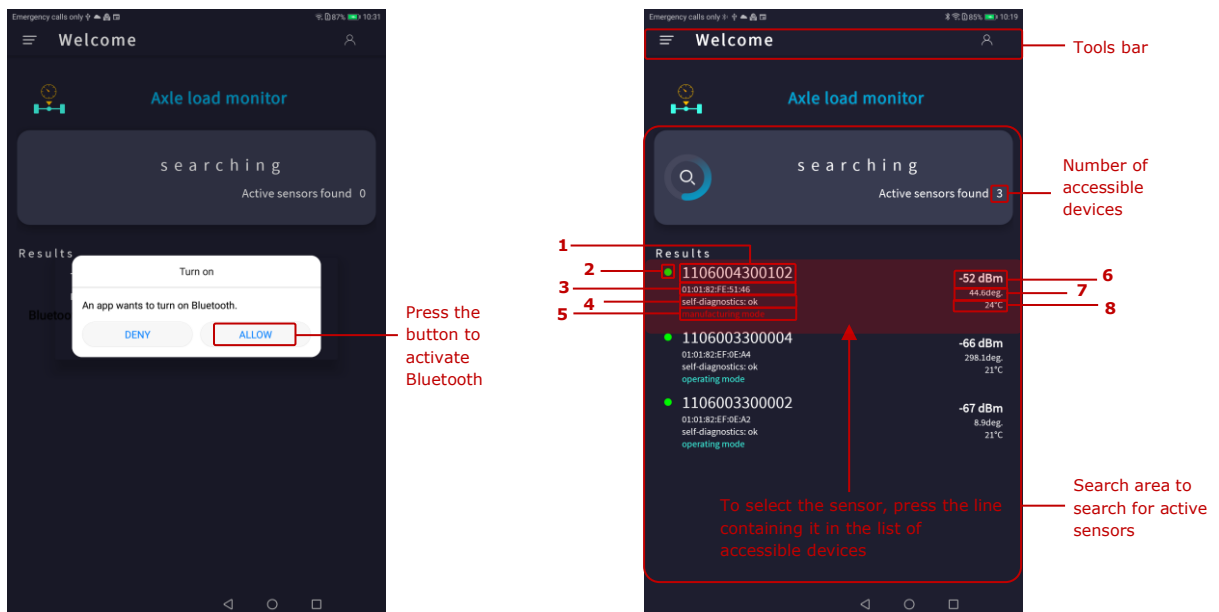

a) offer to allow the Bluetooth connection

b) sensor selection from the list of active devices for monitoring indications

Figure 2 – Establishing connection between the sensor and the mobile device using Axle Load Monitor application

## 6.2 Interface of application

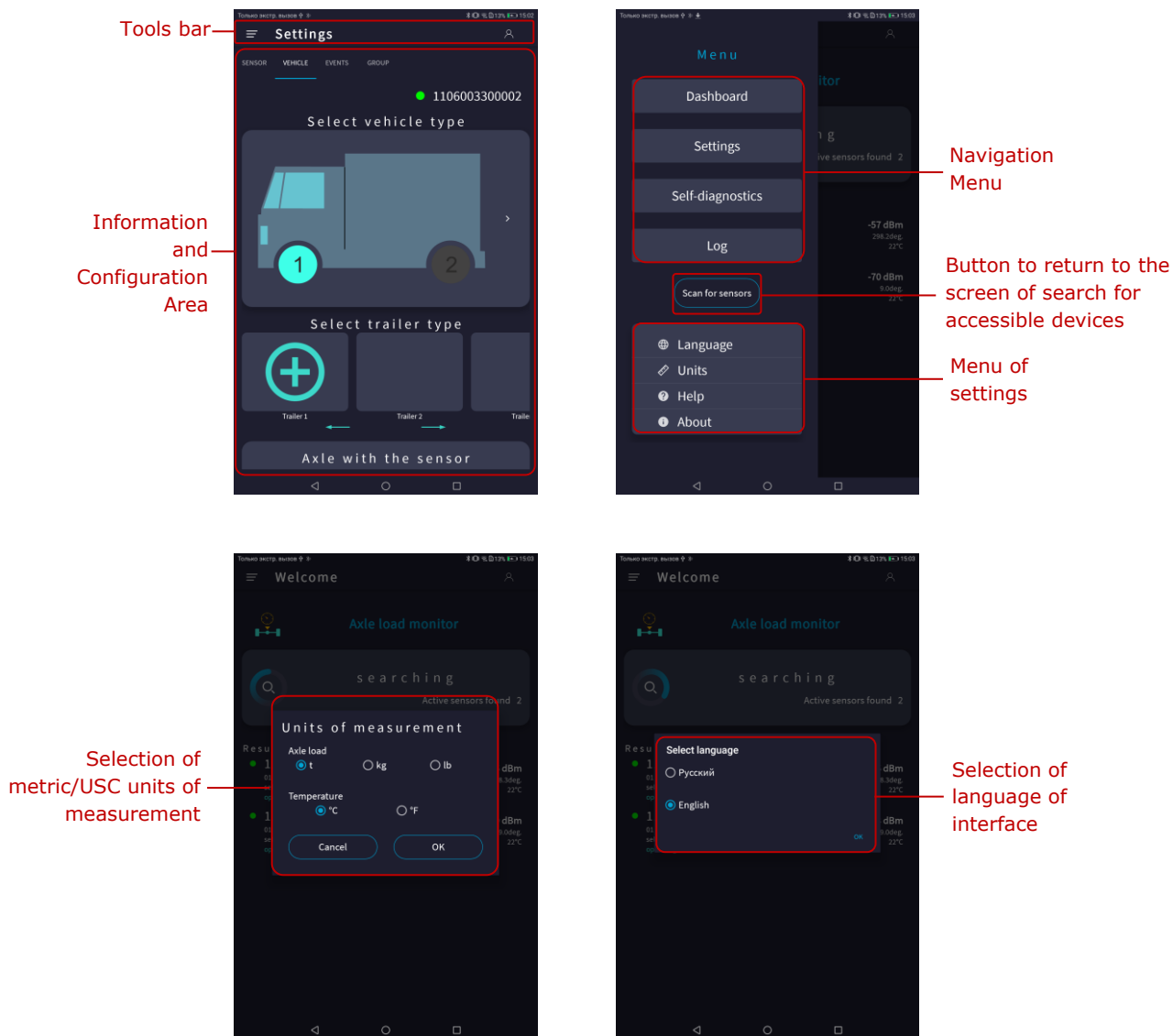
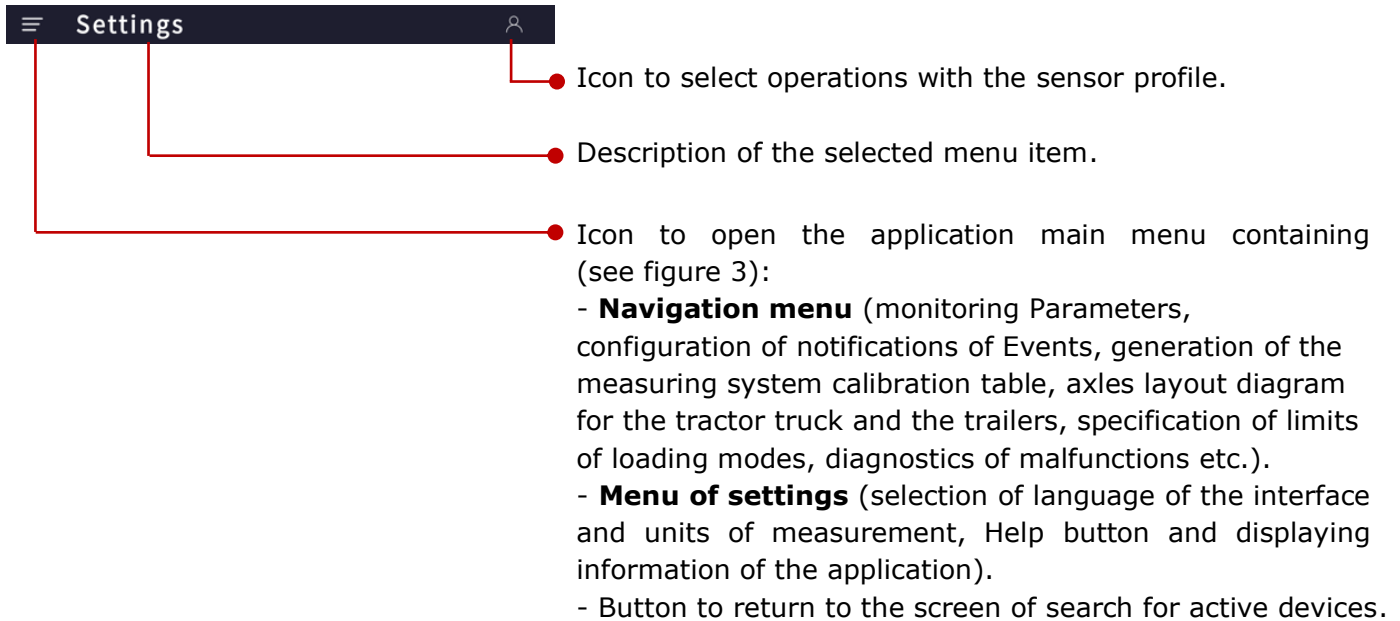

Figure 3 — Interface of Axle Load Monitor mobile application

In the **Information and Configuration** area current parameters and settings of the sensor are displayed.

When working with [GNOM DP S7](#) / [GNOM DDE S7](#), Axle Load Monitor mobile app operates with data ([PGN](#) and [SPN](#)) from [S6 databases](#).

In the **Tools bar** area there are the following elements for use during work with application:





## 6.3 Operations with the sensor profile

The sensor profile is the total of passport data and settings of a specific [GNOM DP S7](#) / [GNOM DDE S7](#).

It is opened by pressing  on the **Tools bar** (see [6.2](#)).

The **Profile** menu contains the following options for operations (see figure 4):

-  **Load from file** — is used to load the sensor profile saved in the memory of the mobile device before. In the window where the file is to be loaded you need to find and select the Profile file (**GNOM\_S7\_\*.prf7**, where \* — sensor serial number);
-  **Save to file** — is used to save the changed settings of the sensor profile in the mobile device memory;
-  **Load default profile** — is used for loading a profile with standard settings.

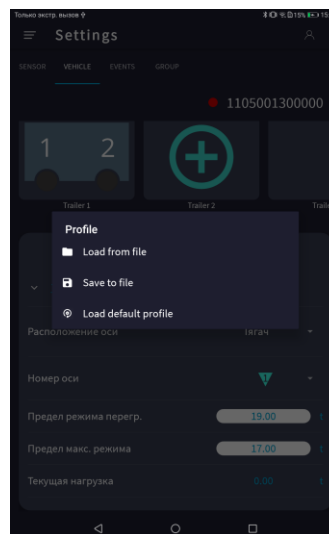

Figure 4 — View of Profile menu Axle Load Monitor mobile application



**IMPORTANT:** All changes of settings made in Axle Load Monitor application are not stored in the sensor, but saved automatically only in the internal memory of a mobile device in the file located in the application installation folder:

**\Axle Load Monitor\** (for Android operational system, version lower than 10).

**\Android\data\com.axle\_load\_monitor\files\** (for Android operational system, version from 10 and higher).

Note — If needed, you may save the sensor Profile file with the file name which is different from the file name assigned by default. However, in this case, the Axle Load Monitor application will not be able to find automatically the required profile, when the communication with the sensor is established.

## 6.4 Calibration of measuring system

**IMPORTANT:** For correct monitoring sensors' readings in Axle Load Monitor application, **first of all, you need to carry out calibration of the measuring system!**



During the calibration procedure, a calibration table is created **for each** sensor mounted on the Vehicle; this calibration table determines the dependence of air pressure in the air suspension circuit (for [GNOM DDE S7](#)) or of the pivot lever angular deviation (for [GNOM DP S7](#)) on various values of axle load (cargo weight).

Using the calibration table stored in the memory of the mobile device, Axle Load Monitor application calculates the current axle load value (cargo weight).

Depending on the aims of monitoring, the following types of calibration are carried out:

**1) "Monitoring the load on the Vehicle axles"** — each monitored axle of the Vehicle is weighed separately (irrespective of the number of sensors installed) and the dependence of indications of each sensor on different values of the axles load is determined.

Special scales for weighing each axle of a vehicle are used to determine values of the axles load in points of the calibration table.

**2) "Monitoring the Vehicle weight"** — the dependence of sensor readings on various values of the Vehicle weight is defined. In order to define the Vehicle weight in points of the calibration table, special scales for vehicles are used; the entire Vehicle climbs on the platform for weighing.

To enhance the accuracy of the cargo weight measurement, we recommend to install two sensors on one Vehicle: for the road train — on the rear axle (bogie) of the tractor truck and on the axle (bogie) of the semi-trailer. For a standard truck — on the front and on the far rear axles. The process of calibration is identical for each of the monitored axles.

**IMPORTANT:** During the calibration of the measuring system you must:



- Load the Vehicle while bearing in mind general health and safety regulations, as well as rules for loading/unloading, locating, and fixing cargo on the platform that are established at a particular road transport company.
- Discrete cargo must be located "front-back" along the Vehicle platform spreading it as evenly as possible all along the platform. During the weighing of the cargo, the most accurate data can be obtained with bulk or liquid cargo.

You can conduct the calibration using one of the following methods:

### 1) Loading of given weights (pieces of known weight)

Load weight is calculated according to formula (1)

$$\text{Load weight} = \text{Total weight of loaded pieces} \quad (1)$$

### 2) Weighing with axle weighing scales

- the most loaded axle of loaded vehicle with unknown weight;

With such calibration the system won't be able to process load weight.

- the whole vehicle loaded with unknown weight;

Load weight is calculated according to formula (2)

$$\text{Load weight} = \text{Weight of fully loaded vehicle} - \text{Weight of empty vehicle} \quad (2)$$



The calibration table is created in the application and is saved in the memory of a specific mobile device using **Settings** submenu (**Sensor** tab) (see figure 5).

To create a calibration table, select the required sensor from the list of accessible devices (see 6.1).

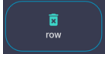
Calibration points are entered in the form of a table of correspondence of current pressure indications in the Vehicle air suspension circuit (**Pressure, kPa** column for [GNOM\\_DDE\\_S7](#)) or the deviation angle (**Pitch, deg** column for [GNOM\\_DP\\_S7](#)) to the Vehicle axle load (**Weight, t** column).

- To add lines into the calibration table, press  button. In case of loading additional cargo into the Vehicle platform, the current value of the sensor readings will be displayed on the left of this button. When the button is pressed, this value is automatically entered into the next line.
- New entries are automatically sorted from low to high pressure value. To delete an entry highlight it and click  button.

Button  is used for deleting all entries of calibration table.

- As soon as the calibration is completed, you may save the calibration table in the form of **\*.ttr7** file in the memory of the mobile device by pressing  button.
- If you need to load the file of the calibration table which was saved in the memory of the mobile device before (e.g. in case of the sensor replacement), use  button.
- As soon as the calibration table is completed, save the modified profile of the sensor in the memory of the mobile device (see 6.3).
- The calibration of the measuring system is completed.

#### ATTENTION:

**1)** The points of the calibration table are to be selected within the range from the minimal axle load (unloaded Vehicle) to the maximum possible (maximally loaded Vehicle).

**2)** The number of calibration points is in proportion to the axle load measurement accuracy. The recommended number of the calibration points — **2...6**. You can enter **up to 30 points** at a maximum in the Axle Load Monitor application. The calibration table should contain at least two points: "completely unloaded Vehicle" and "maximally loaded Vehicle".

**3)** The maximum possible axle load value in the calibration point is **655 metric tons**.

**4)** In the process of entering the calibration points, it should be borne in mind that the Axle Load Monitor application displays data with the time lag **no less than 10 s**.

**5)** In case of replacing old Android device, it is necessary to copy profile of particular sensor into memory of new mobile device (see 6.3) or repeat the calibration procedure of the measuring system.



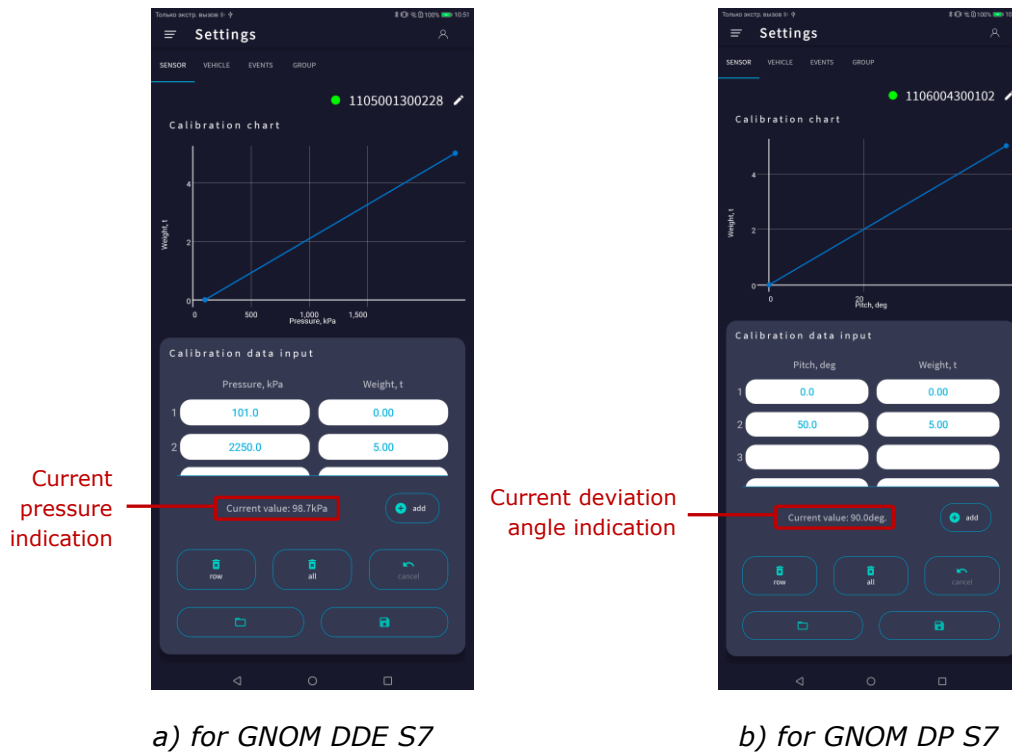

Figure 5 – Example of creating a calibration table in Axle Load Monitor mobile application



**RECOMMENDATION:** In case wireless [GNOM DDE S7](#) / [GNOM DP S7](#) sensors operate within the [Telematics system](#), the calibration table created in the application may be used for respective settings of the [Server](#) or [Terminal](#) software.

## 6.5 Adaptation of axle load indications for a specific Vehicle

Axle Load Monitor is configured for a specific [Vehicle](#) in the following way:

**1)** select the sensor (see [6.1](#)) mounted on the Vehicle most loaded axle from the list of accessible devices. The application will calculate and display the value of axle load for this sensor.

**2)\*** To monitor axle load readings of a complex Vehicle (road train) equipped with several wireless sensors, you need to create a group comprising all [GNOM\\_DP\\_S7](#) and/or [GNOM\\_DDE\\_S7](#) wireless sensors mounted on the Vehicle (**up to 11 pcs.** at a maximum).

You need to select Master sensor for the road train from the list of accessible devices (e.g. sensor mounted on the most loaded axle of the tractor truck). The application will calculate and display the total axle load value on all Vehicle axles.

Then, Slave sensors from the number of sensors mounted on the trailers or on other axles of the tractor truck are added to Master sensor (**Settings** submenu, **Group** tab). Indications of each Slave sensor will be displayed on the screen of the mobile device and counted by the application during the calculation of the total Vehicle axle load value.





**IMPORTANT:** Before that, you are to save profiles of Master sensor and Slave sensors in the memory of the mobile device you are using, in the application installation folder (see [6.3](#)). The profile of each connected sensor must contain the respective calibration table (see [6.4](#)).

You should not save the sensors profiles' files with the name different from the name specified by default. Because if so, the application would not be able to find automatically the needed profile during the establishment of connection with the appropriate sensor.

Sensors are added from **Searching** area to the group of sensors by pressing  button, to the right of the serial number of the respective sensor (see figure 6 a).

By pressing  button in the lower portion of **Multisensor group** area, you may add a sensor with any serial number specified by you.

Using  button, you may delete any Slave sensor from the group. However, you cannot delete Master sensor from the group.

The sensors' group number is generated automatically and always corresponds to the serial number of Master sensor. To enter a new group number, you may use  button located to its right.

For each sensor of the group are displayed: serial number, current axle load readings, data of presence/absence of active malfunctions and the indicator of time of receiving the latest message (see figure 6 b).

The total axle load indications measured by a group of sensors are displayed in **Total** field, in the upper right portion of **Group** tab (**Dashboard** submenu).

---

\* This paragraph is applicable only during the configuration of the application for monitoring axle load of the Vehicle on which more than one wireless sensor is mounted.

**WARNINGS:**



- 1) The serial number of the sensor which is being added to the group is displayed in red, in case its profile is not saved in the memory of the mobile device and/or the calibration table is missing. Also, the red-colored warning **No profile** will be displayed in **Dashboard** submenu (**Group** tab) for this sensor.
- 2) In case there are active sensor malfunctions, (!) warning sign will be displayed under its serial number in **Self-diagnostics** line (see figure 6 b).





a) creation of a group of sensors for monitoring axle load indications

b) displaying indications of axle load measured by a group of sensors

Figure 6 — Example of summation of indications of several GNOM S7 wireless sensors on a complex Vehicle

3) Using visualization tools that are available in the application (**Settings** submenu, **Vehicle** tab), specify the layout of the axles' location in the monitored Vehicle for the tractor truck and for the trailers (if any) (see figure 7).

To specify the tractor truck axles location layout, press the Vehicle picture in **Select vehicle type** area and select the appropriate layout among the offered options.

If there are trailers hitched to the monitored Vehicle, add the necessary number of single-axle or two-axle trailers hitched to the Vehicle (5 pcs. at a maximum) by pressing  **Trailer 1...Trailer 5** buttons in **Select trailer type** area. To delete the added trailer, press the appropriate button, then press  icon in the appearing window.

4) By pressing the sensor number in **Axle with the sensor** area, link it to the respective Vehicle axle and set thresholds for loading modes. The list of settings contains the following [Parameters](#) (see figure 7):

- **Axle location** — in the dropdown list specify the Vehicle element (**Truck** or **Trailer 1...5**) in which the monitored axle with the selected sensor is located.
- **Axle number** — in the dropdown list specify the number of the monitored tractor truck/trailer axle on which the selected sensor is mounted, in accordance with the axles' location layout diagram.  
After linking the sensor to the axle, the respective wheel on the tractor truck/trailer layout will be highlighted in blue.
- **Overload limit** — in this field, specify the threshold value for the "Overload" mode of the Vehicle loading. In case this value is exceeded, the application will automatically identify "Overload" Event and issue the appropriate notification.
- **Maximum limit** — in this field, specify the threshold value for the "Maximum" loading mode, to monitor the exceeding of the maximum Vehicle load. In case of overload, current sensor readings will be displayed in yellow.
- **Current load** — current readings of axle load are displayed.

During the application configuration for the created group of sensors, you need to establish linking to respective axles and specify loading thresholds for each sensor of the group.

6) For correct display of readings during the next session of work with the application, save the modified sensor profile in the memory of the mobile device (see [6.3](#))

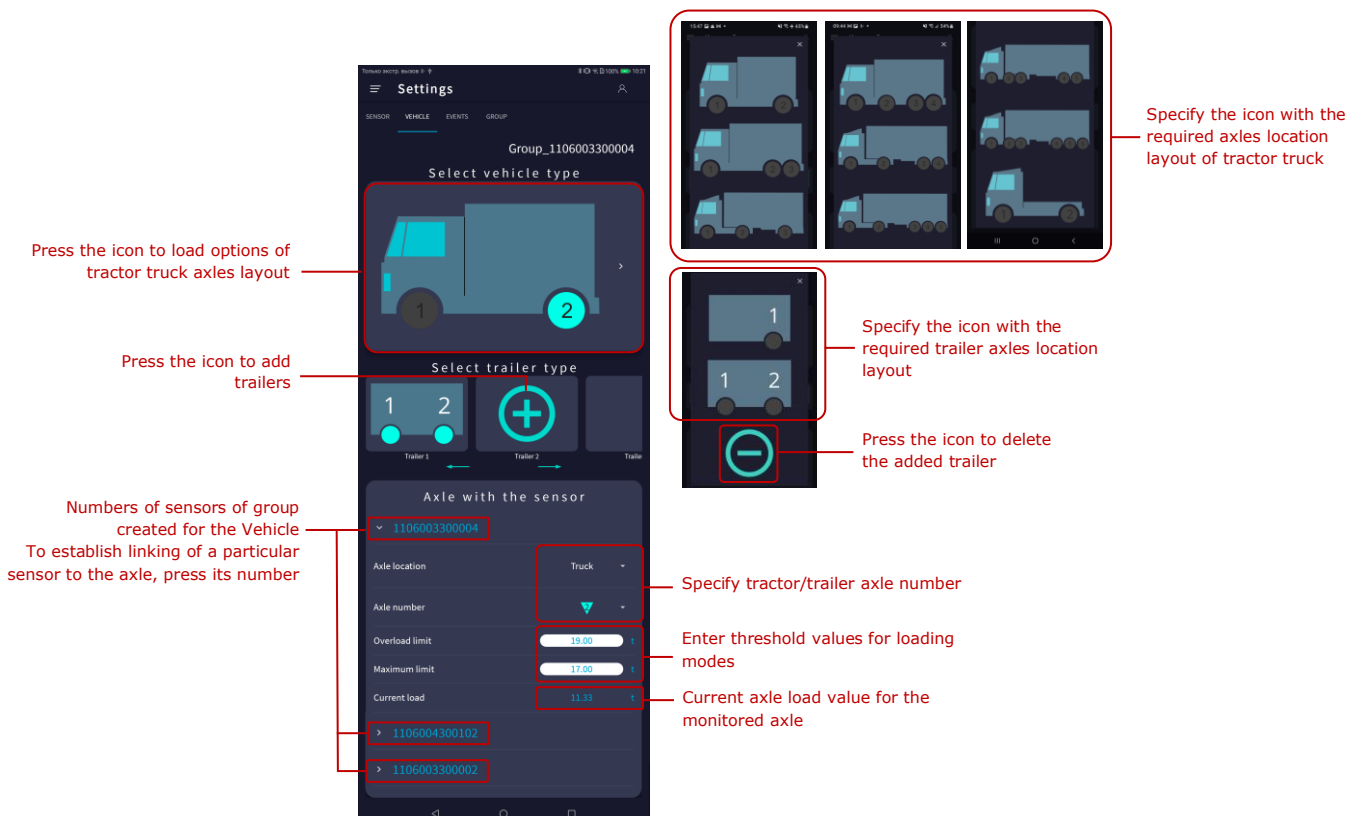

Figure 7 — Example of establishing linking of wireless sensors to their respective axles and entering threshold values for loading modes

## 6.6 Configuring Events detection function and displaying recorded Events

**Events detection** function serves for automatic recording of “Overload” [Event](#) by the application and for notifying the user of its occurrence.

By default, this function is off in Axle Load Monitor application. To activate it, press **Overload** line (**Settings**, submenu, **Events** tab) and move right the slide switch in the opening window of settings (see figure 8). This function is helpful to avoid penalties for exceeding limits of axle load.



**WARNING:** For correct operation of automatic detection of “Overload” Event function, the profile of the respective sensor must contain the calibration table (see [6.4](#)) and the specified threshold value for “Overload” loading mode (see [6.5](#)).

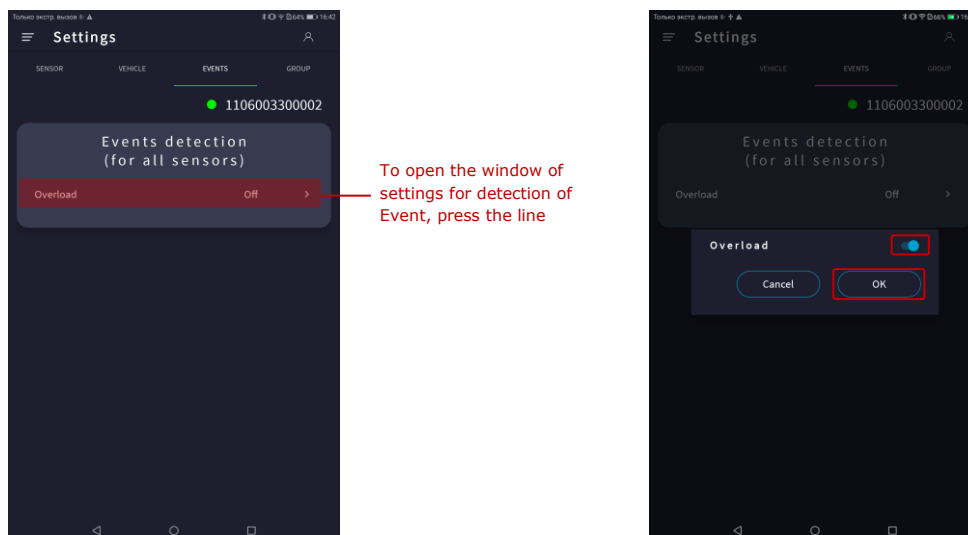

a) tab to configure the Events identification function

b) activation of “Overload” Event identification

Figure 8 — Settings of the Events Detection function in the Axle Load Monitor application

Information windows appearing on the display of a mobile device in case Events occur (see figure 9 a) are accompanied by a sound signal and vibration (in case the sound and vibration signals are switched on in the mobile device employed).

For Events the following information is displayed:

- date and time of its recording;
- number of the overloaded axle;
- axle load value.

The list of all Events recorded during work with the sensor, until the working session with Axle Load Monitor is completed, is displayed in **Dashboard** submenu (**Events** tab). To view detailed information on a specific Event from the list, press its line (see figure 9 b).

Information on the latest Event and on the total number of recorded Events is displayed in **Dashboard** submenu (**Data** tab). To switch over to the list of all Events, press the latest Event line (see [figure 10](#)).

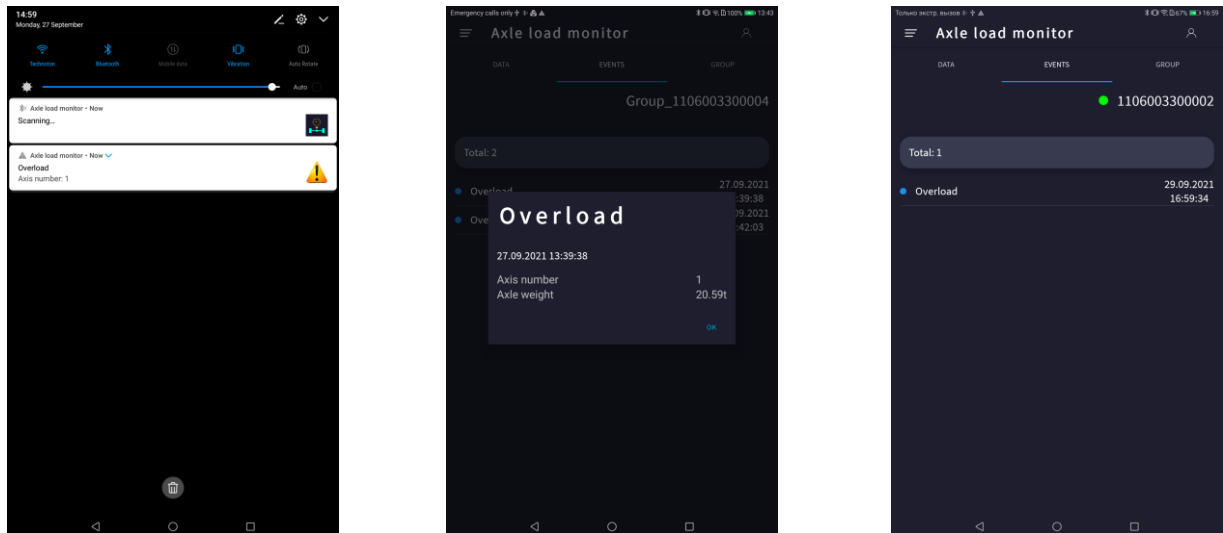

a) examples of the information windows of "Overload" Event

b) example of the list of recorded Events

Figure 9 — Display Events information in the Axle Load Monitor application

For automatic identification of Events during the next session of work with Axle Load Monitor application, you need to save the changed sensor profile (see [6.3](#)) in the memory of the smartphone/tablet used.

## 6.7 Monitoring and recording readings



**IMPORTANT:** Correct monitoring of indications of [GNOM DP S7](#) / [GNOM DDE S7](#) sensors in Axle Load Monitor is possible only after conducting the calibration of the measuring system (see [6.4](#)) and after adaptation of axle load indications for a specific Vehicle (see [6.5](#)).

In order to monitor axle load indications in the application, establish connection with the required sensor from the list of accessible devices (see [6.1](#)) and open **Dashboard** submenu in which on the screen of the mobile device are displayed data on:

- 1) Current values of [Parameters](#) (**Data** and **Group** tabs):
  - Axle load;
  - Vehicle loading mode ("Maximal" / "Overload")\*;
  - Ambient temperature.
- 2) Recorded "Overload" [Events](#) (**Data** and **Events** tabs).
- 3) Presence /absence of active malfunctions (**Data** and **Group** tabs).

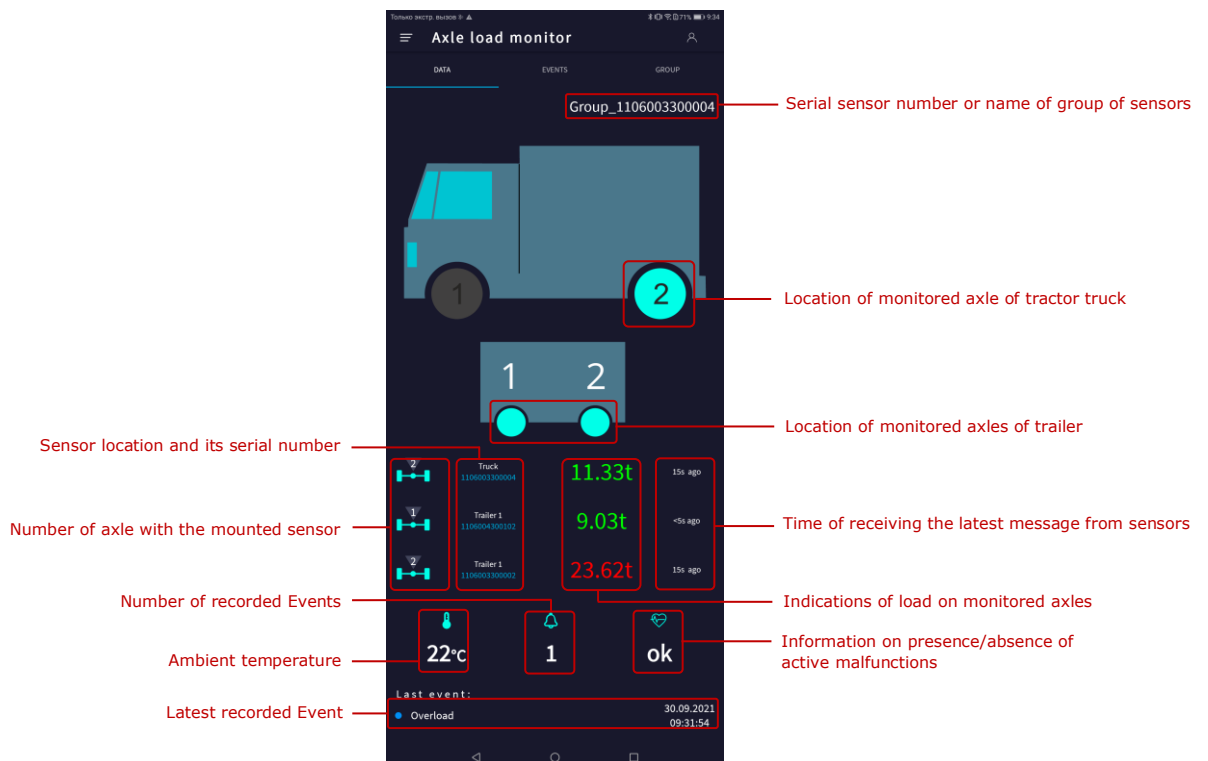

Figure 10 — Example of the screen of monitoring the current axle load indications for a road train in Axle Load Monitor application

\* In "Maximal" mode of loading, axle load indications are highlighted in yellow, while in "Overload" mode — they are highlighted in red.

In order to record indications, open **Log** submenu. You may activate registration (logging), with saving values of the following Parameters in the log file by moving right **Data logging** slide switch (see figure 11):

- Axle load;
- Compressed air pressure in the compressed air system (only for [GNOM DDE S7](#));
- Pivot lever angular deviation (only for [GNOM DP S7](#));
- Ambient temperature.

The maximum number of control points displayed — 200. The number of points recorded in the log file — not limited.

Whenever you tick the **Scrolling** field, each added line of the Parameters will be displayed in the bottom portion of the table.  button serves to clear the list of all control points registered during logging.

Log files names are generated automatically (**yyyy.mm.dd\_h:m:s\*.txt**, where \* - sensor serial number).

Log files are placed into the application installation folder, in the memory of the mobile device:

**\Axle Load Monitor\Logs\** (for Android operational system, version lower than 10);

**\Android\data\com.axle\_load\_monitor\files\Logs\** (for Android operational system, version from 10 and higher).

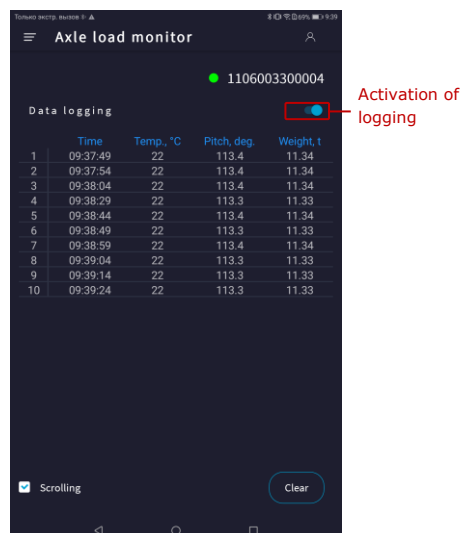

Figure 11 — Example of logging current indications of axle load wireless sensor in Axle Load Monitor application

## 6.8 Malfunction diagnostics



**Self-diagnostics** submenu in Axle Load Monitor application serves to monitor the quality of performance of the selected [GNOM DP S7](#) / [GNOM DDE S7](#) sensor. Names of all sensor active malfunctions (if any) for the whole working session with the application (see figure 12 b) and their indicators (see table 2) are displayed in the submenu window, in **Malfunctions** area. In case no active malfunctions are detected, the appropriate message in **Malfunctions** area is displayed (see figure 12 a).

You can also monitor the quality of the sensors performance:

**1)** In the list of identified accessible devices (**Welcome** screen) (see [6.1](#)) and in **Group** tab (**Dashboard** submenu) (see [6.5](#)), where **Self-diagnostics: Ok** message is displayed under the serial number of each sensor, in case no active malfunctions are detected; in case there are some, — **Self-diagnostics (!)** is displayed.

**2)** In **Data** tab (**Dashboard** submenu) (see [6.7](#)), where **ok** sign is displayed, in case no active malfunctions are detected; in case there are some, — **(!)** is displayed.

Table 2 – Meaning of signals of active malfunctions indicator of sensors

Signal type	Signal color	Signal values
	Red	Active sensor malfunction identified (see the list of all possible malfunctions in <a href="#">GNOM S7 operation manual</a> )
	Green	Active sensor malfunction eliminated

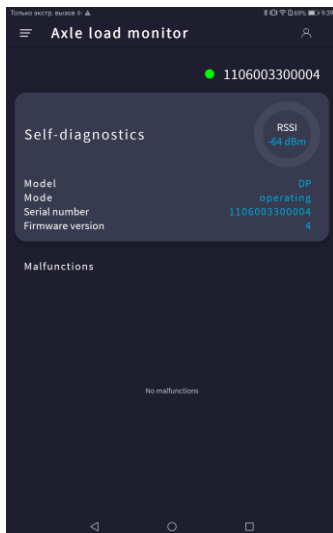

a) without active malfunctions

Indicator of active sensor malfunctions

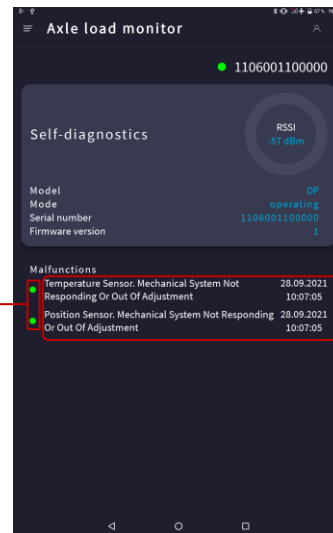

List of active sensor malfunctions

b) there are active malfunctions

Figure 12 — Sensor quality control in the Axle Load Monitor application

## 7 Procedure for deleting the application from Android device

To delete the application, you should open it in Google Play in the smartphone/tablet you are using and press  button.

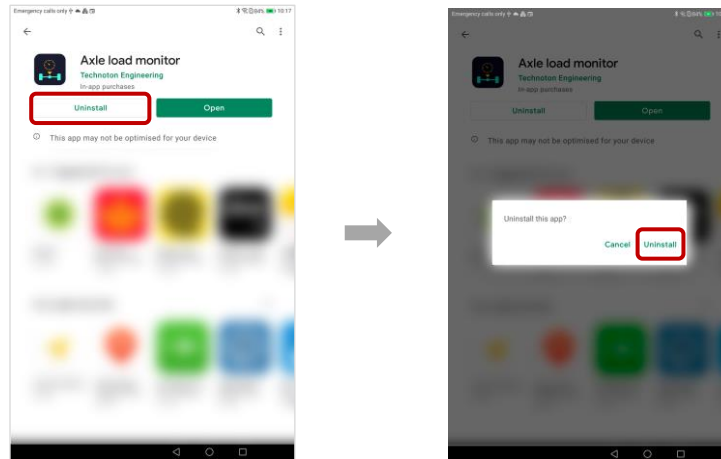

You may also use the standard method of deleting Android-based applications: holding  icon with your finger, drag and drop it into **Delete** wastebasket which appears on top of the screen.

## Contacts

### Development, technical support



[sales@jv-technoton.com](mailto:sales@jv-technoton.com)

[support@jv-technoton.com](mailto:support@jv-technoton.com)



## Annex A

### Videography

#### 1) Video "GNOM DP S7 axle load sensors, diving basics"

A common thing for Technoton technicians is to conduct "survival" experiments on our telematics hardware. We conducted an experiment on a new axle load sensor GNOM DP S7. In the morning we had put the sensor into the water, and in the afternoon get the sensor out of the water and checked out water impermeability — after 7 hours spent in the water, GNOM DP S7 worked as if nothing had happened! The sensor still showed the correct angles and temperature.



<https://www.youtube.com/watch?v=27VpRVeGpIU>

#### 2) Video "GNOM DP S7 axle load sensor: game of ice"

We conducted another experiment: sent the sensor for 3 days to the freezer! When GNOM S7 sensor was pulled out, it showed -23 °C, and continued to display correct data values.



<https://www.youtube.com/watch?v=hRnEOcNWJIE>

#### 3) Video "Axle load monitoring for leaf spring suspension. Demo stand"



<https://www.youtube.com/watch?v=ZEPp5FCZcBY>

#### 4) Video "Axle load monitoring for air suspension. Demo stand"



<https://www.youtube.com/watch?v=eUsBp1qRhwY>

#### 5) Animation "GNOM DP position sensors. Mounting and application".

The animation shows sensor mounting schemes for biaxial and threeaxial vehicles as well as instance of the diagrams built on sensor data in vehicle monitoring system.



<https://www.youtube.com/watch?v=9njffVByJog>

6) Other [JV Technoton videos](#) are on the YouTube channel which is regularly updated:



<https://www.youtube.com/channel/UCq7EF3DHrgl7fOWB2ynsR-A>