

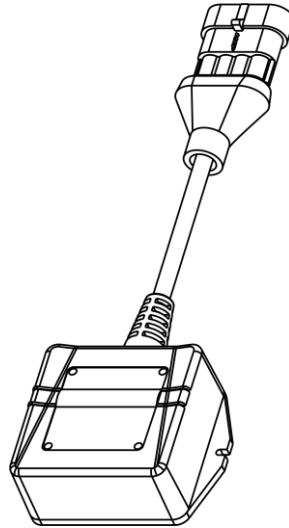

FUEL CONSUMPTION INDICATOR

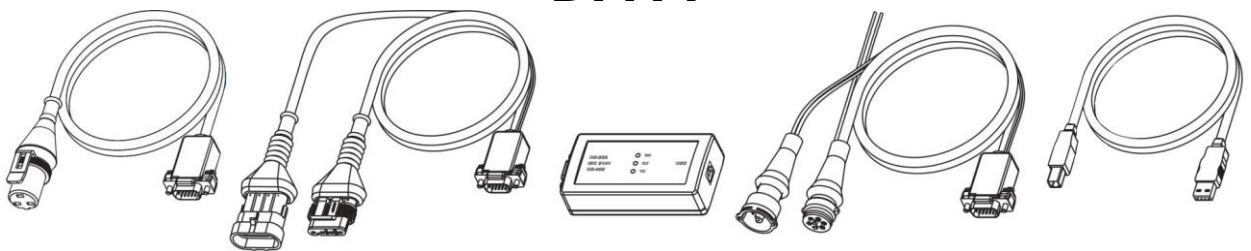

DFM i



SK DFM service adapter

OPERATION MANUAL
(includes Service DFM software manuals)

Version 1.0



TECHNOTON
ADVANCED VEHICLE TELEMATICS

Contents

| | |
|--|----|
| Contents | 2 |
| Revision history | 3 |
| Structure of external links | 4 |
| Terms and Definitions | 5 |
| Introduction | 6 |
| 1 General information and technical specifications of DFM i | 8 |
| 1.1 Purpose of use and application area | 8 |
| 1.2 Exterior view and delivery set | 10 |
| 1.3 Design and operation principle | 11 |
| 1.4 Technical specifications | 12 |
| 1.4.1 Main specifications | 12 |
| 1.4.2 Input signal specifications | 13 |
| 1.4.3 Power supply mode | 14 |
| 1.4.4 Recording engine operation mode | 15 |
| 1.4.5 Displayed data | 16 |
| 1.4.6 Protection from tampering of indications | 19 |
| 1.4.7 Overall and mounting dimensions | 20 |
| 2 DFM i installation | 21 |
| 2.1 Exterior inspection prior to starting works | 21 |
| 2.2 Choosing installation place | 22 |
| 2.3 Electrical connection | 23 |
| 3 Configuration of DFM i using the service adapter | 26 |
| 3.1 SK DFM purpose of use | 26 |
| 3.2 Hardware requirements | 27 |
| 3.3 Composition of the service adapter | 28 |
| 3.3.1 Exterior view and delivery set | 28 |
| 3.3.2 Universal service adapter | 29 |
| 3.3.3 USB A-B cable | 30 |
| 3.3.4 DFM i service cable | 31 |
| 3.4 Service adapter connection | 32 |
| 3.4.1 Exterior inspection prior to connection | 32 |
| 3.4.2 Operation restrictions | 33 |
| 3.4.3 DFM i connection to the PC | 34 |
| 3.5 Service DFM software operation | 36 |
| 3.5.1 User interface | 36 |
| 3.5.2 Working with DFM i profile | 38 |
| 3.5.3 Adapting indicator to operational conditions | 40 |
| 3.5.4 Reading indications of Counters | 41 |
| 3.5.5 Operation check | 42 |
| 3.5.6 Firmware upgrade | 43 |
| 3.5.7 Completion of the working session with the software and switching off the indicator | 45 |
| 4 Packaging | 46 |
| 5 Storage | 47 |
| 6 Transportation | 48 |
| 7 Utilization/re-cycling | 49 |
| Contacts | 50 |
| Annex A Videography | 51 |

Revision history

| Version | Date | Editor | Description of changes |
|----------------|-------------|---------------|-------------------------------|
| 1.0 | 09.2021 | OD | Basic version. |

Structure of external links

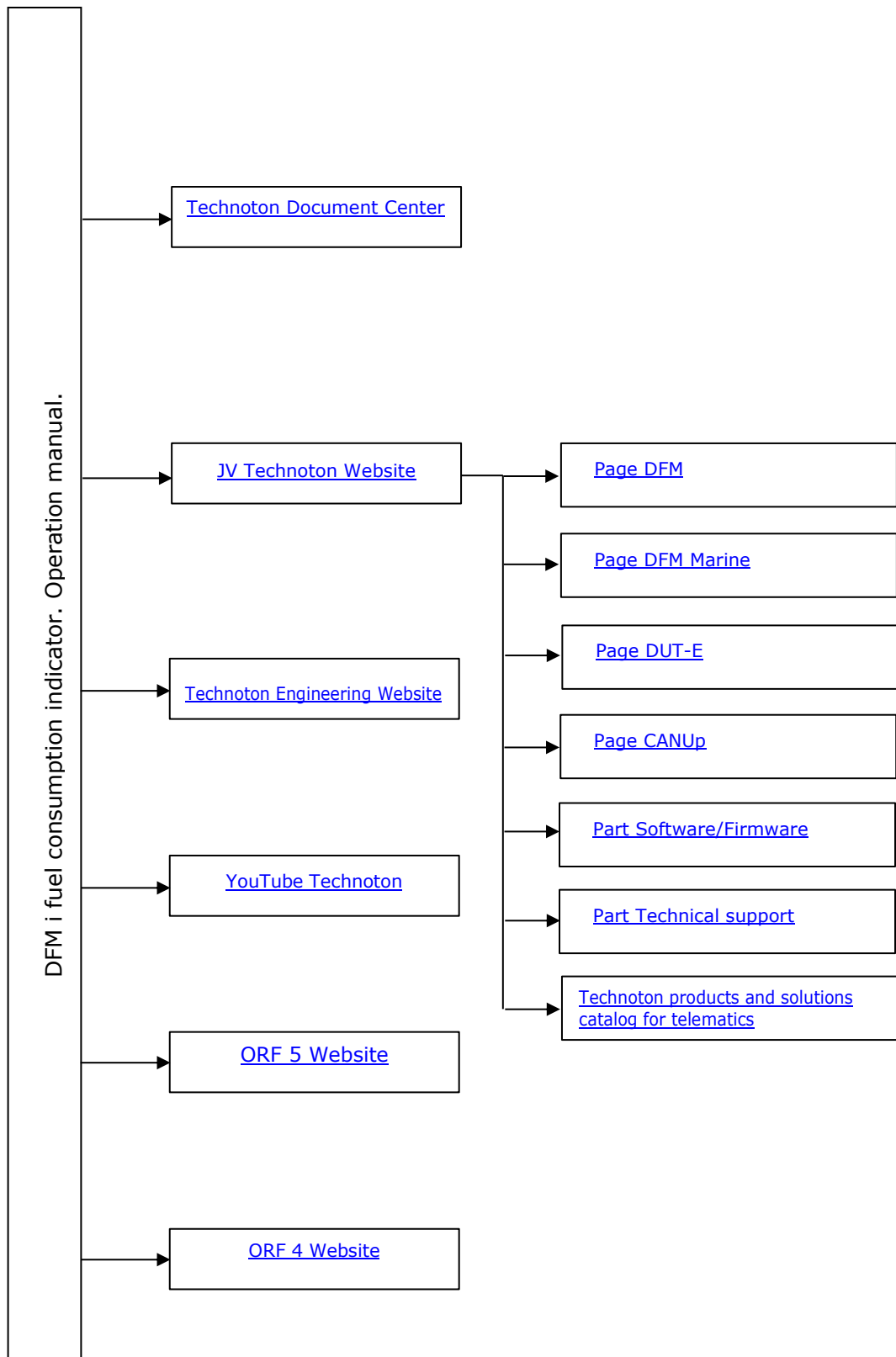

Terms and Definitions

Onboard equipment (OE) — Telematics system elements, directly installed in Vehicle.

Onboard reports (the Reports) — information about vehicle which is returned to a user of Telematics system in accordance with inputted criteria. The Reports are generated by a terminal unit both periodically (Periodic reports) and on Event occurrence (Event report).

GNSS (Global Navigation Satellite System) — System for area positioning of an object through satellite signal processing. GNSS is composed of space, ground and user segments. Currently, there are several GNSSs: GPS, GLONASS, Galileo, BeiDou.

Parameter — time-varying or space characteristic of the Vehicle (SPN value). For example, speed, fuel volume in the tank, hourly fuel consumption, coordinates. Parameter is usually displayed in the form of graph, or averaged data.

Server (AVL Server) — hardware-software complex of Telematics service [ORF 4](#) / [ORF 5](#), used for processing and storage of Operational data, formation and transmission of Analytical reports through Internet by request of users.

Event — relatively rare and sudden change in SPN. For example, applying the magnetic field to the fuel flow meter in order to falsify indications of the hourly fuel consumption is the "Interference" Event. An Event can have one or several characteristics. Thus, the "Interference" Event has the following characteristics: date/time and duration of the interference. When the Event occurs, a terminal unit registers the time of occurrence, which is later mentioned in a report on the event. Thus, the Event is always attached to exact time and place of occurrence.

Counter — cumulative numerical characteristic of Parameter. Counter is displayed by a single number and over time its value is increasing. Examples of counters: fuel consumption, trip, engine hours counter etc.

Telematics terminal (Terminal, Tracking device, Telematics unit) is a unit of Telematics system used for reading the signals of Vehicle standard and additional sensors, getting location data and transmitting the data to the Server.

Telematics system — complex solution for vehicle monitoring in real time and trip analysis. The main monitored characteristics of the vehicle: Route, Fuel consumption, Working time, technical integrity, Safety. It includes On-board report, Communication channels, Telematics service ORF 4 / ORF 5.

Vehicle an object controlled within Telematics system. Usually Vehicle means a truck, tractor or bus, sometimes a locomotive or river boat. From Telematics system point of view, stationary objects are also considered to be vehicles: diesel gensets, stationary tanks, boilers/burners.

Introduction

Recommendations and rules set out in this Operation Manual apply to **DFM i fuel consumption indicator** (further on — [DFM i](#)), model code **047** and **SK DFM service adapter** (further on — SK DFM) manufactured by [Technoton](#).

The model code of DFM is identified by the first three digits of its serial number printed on the label on the bottom part of its casing or printed on package label:



The manual contains information on design, operation principle, specifications and instructions on connection, configuration and use of DFM i.

DFM i — a portable, adjustable indicator aimed to record and display fuel consumption readings and operation time of the engine or any other fuel consumer, based on the output pulse signal of the flow meter.

SK DFM service adapter serves for data exchange between DFM i and personal computer (PC).

DFM i key features:

- versatility — compatibility with pulse fuel flow meters of different manufacturers;
- recording real fuel consumption and operation time of fuel consumer – total and in different consumption modes: “Idle”, “Optimal”, “Overload”, “Tampering” and “Interference”;
- monitoring petrol and liquid gas consumption by light commercial vehicles (LCV)*;
- inbuilt battery provides the indicator operation and storage of all [Counters](#) and [Events](#) in the internal memory in case of the external power supply cutoff;
- option to configure limits of operation modes of the fuel consumer based on the hourly fuel consumption;
- light and compact design, simple mounting and handling;
- convenient remote reading the flow meter indications from the driver’s cabin;
- protection from tampering;
- signal cables and fixing elements in the [mounting kit](#);
- convenient switching over indication modes (magnetic key included into the delivery set);
- conformity with European and national standards and directives;
- rich experience accumulated during the period of its use, high-quality [technical support](#) and [documentation](#).

* In case of using together with [NozzleCrocodile](#) or Nozzle BMCrocodile contactless reader.

For DFM i configuration using cable connection to the PC you should use SK DFM service adapter (to be purchased separately) and the Service DFM service software (the software current version can be downloaded at <https://www.jv-technoton.com/>, section [Software/Firmware](#)).



ATTENTION: It is strongly recommended to follow strictly the instructions of the present Manual when using, mounting or maintaining DFM i.

[The Manufacturer](#) guarantees DFM i compliance with the requirements of technical regulations subject to the conditions of storage, transportation and operation set out in this Manual.



ATTENTION: Manufacturer reserves the right to modify DFM i specifications that do not lead to a deterioration of the consumer qualities without prior customer notice.

1 General information and technical specifications of DFM i

1.1 Purpose of use and application area

DFM i is designed for remote indication of current readings of flow meters with pulse output (see figure 1):

- hourly fuel consumption in fuel lines of engines of [Vehicles](#) or in fixed units;
- total fuel consumption*;
- period of fuel consumer operation — total and in different modes of operation.

* DFM i also accumulates fuel consumption Counters in different modes of the consumer operation. Their readings are taken using the service software (see [3.5.4](#)).

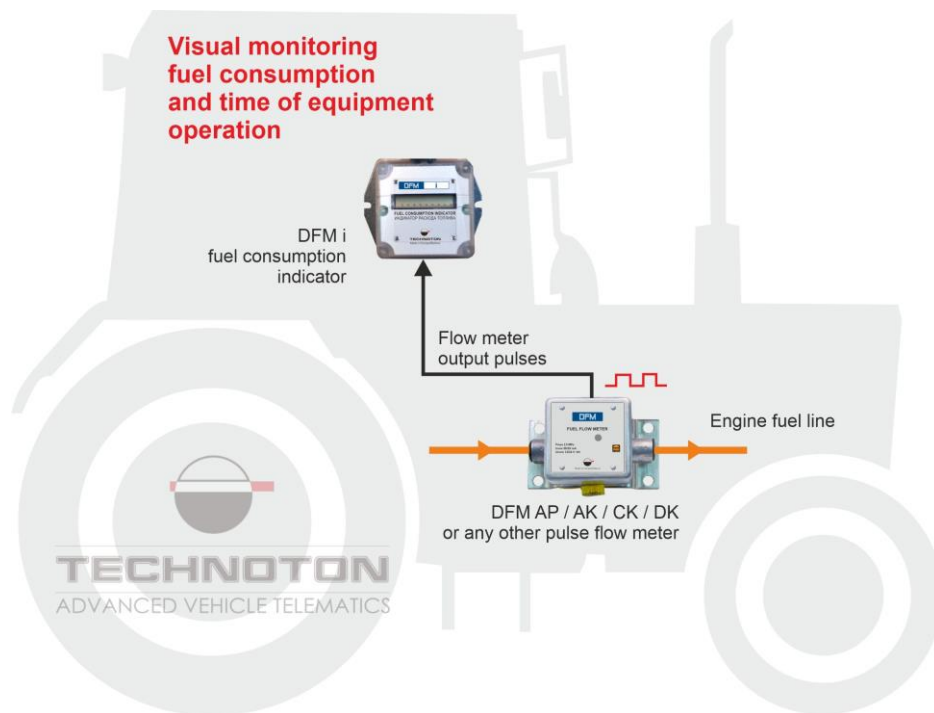

Figure 1 — Purpose of DFM i fuel consumption indicator

Application area (see figure 2):

DFM i operates in combination with pulse fuel flow meters (models DFM AP/AK/CK/DK), or with [NozzleCrocodile](#)/Nozzle BMCrocodile contactless readers manufactured by [Technoton](#) or with flow-type flow meters with output pulse signal produced by other manufacturers.

DFM i is employed as part of [Telematics systems](#) or independently, as inexpensive onboard device for visual monitoring fuel consumption and time of the Vehicle operation in cases, when immediate access to flow meters to take readings is limited or absolutely impossible. DFM i can be mounted in the driver's cabin or in a different location of a [Vehicle](#) which can be convenient for visual taking readings.



a) using DFM i together with [DFM](#) pulse-type fuel flow meter in vehicles and tractors

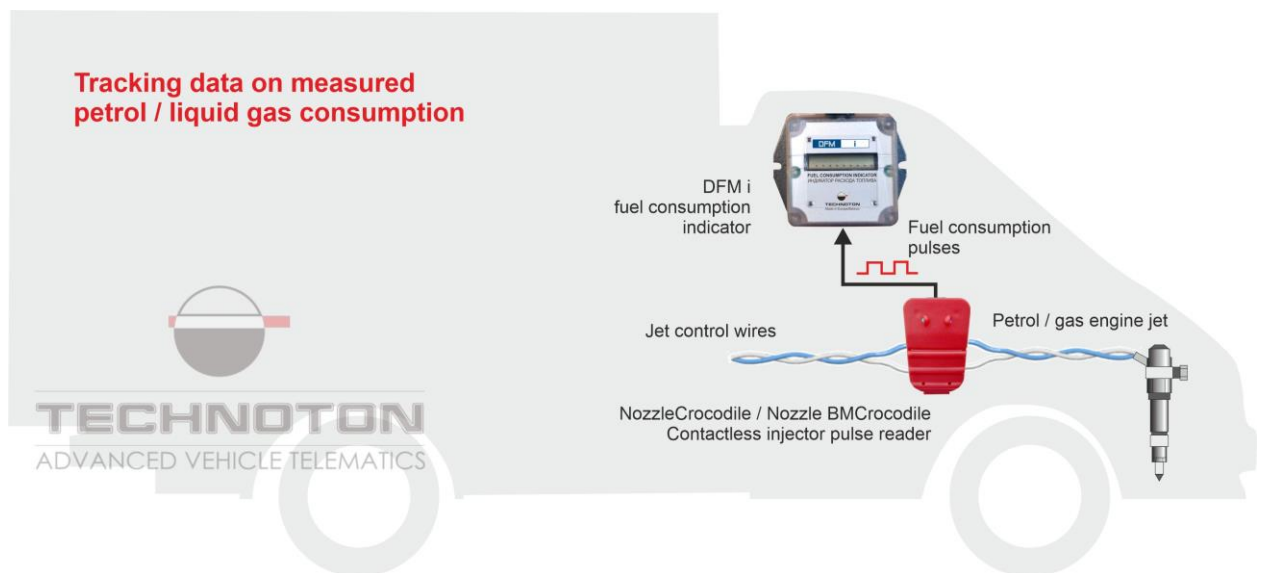

b) using DFM i together with [NozzleCrocodile](#)/[Nozzle BMCrocodile](#) contactless reader in LCV

Figure 2 — Examples of the area of application of DFM i fuel consumption indicator

1.2 Exterior view and delivery set

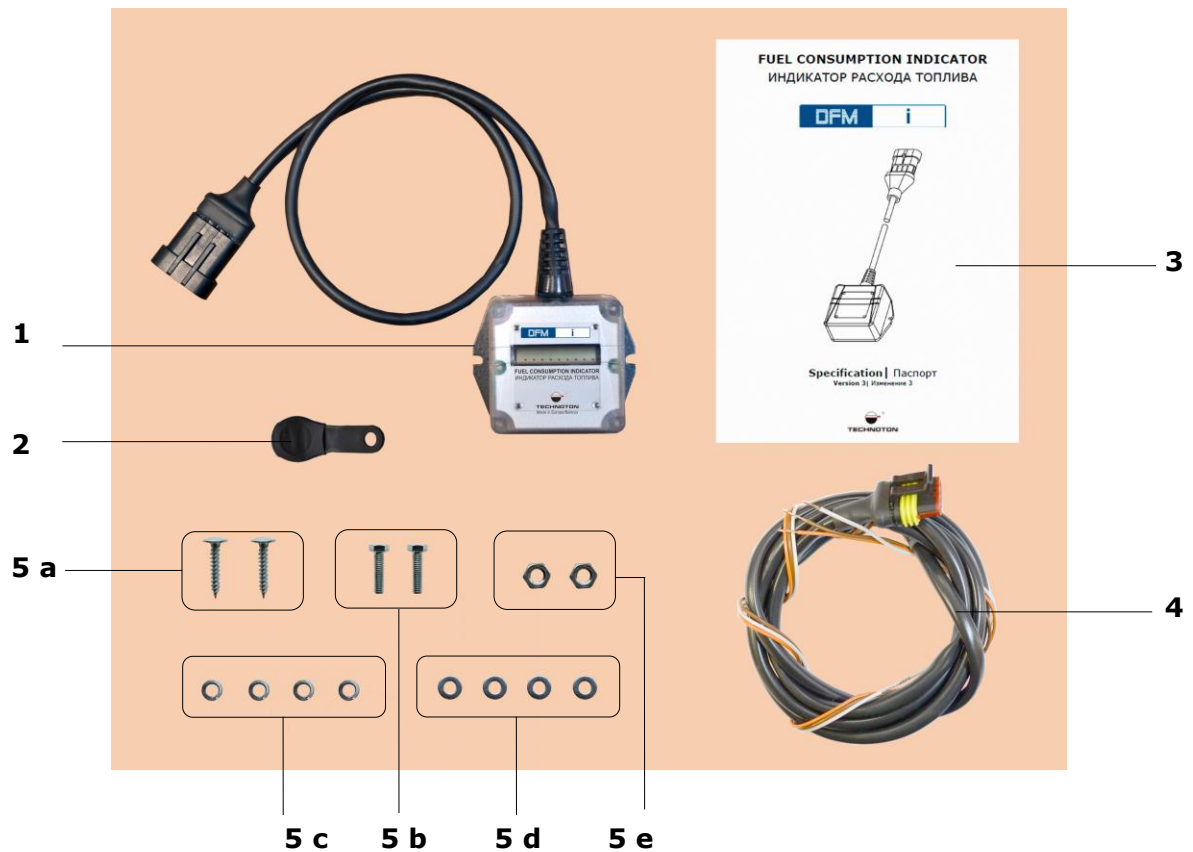

- | | | |
|----------|---|----------|
| 1 | DFM i fuel consumption indicator | - 1 pc; |
| 2 | Magnetic key | - 1 pc; |
| 3 | Specification | - 1 pc; |
| 4 | Signal cable (2 m) | - 1 pc; |
| 5 | Mounting kit (1 pc) including: | |
| | a) self-tapping screw 4.2x25 | - 2 pcs; |
| | b) screw M4x16 | - 2 pcs; |
| | c) lock washer M4 | - 4 pcs; |
| | d) washer M4 | - 4 pcs; |
| | e) nut M4 | - 2 pcs. |

Figure 3 — DFM i delivery set

1.3 Design and operation principle

[DFM i](#) consists of the electronic module with LCD display under the transparent plastic cover (**1**), the base with fixing elements for mounting (**2**), the interface cable (**3**) with a connecting plug (**4**) (see figure 4).

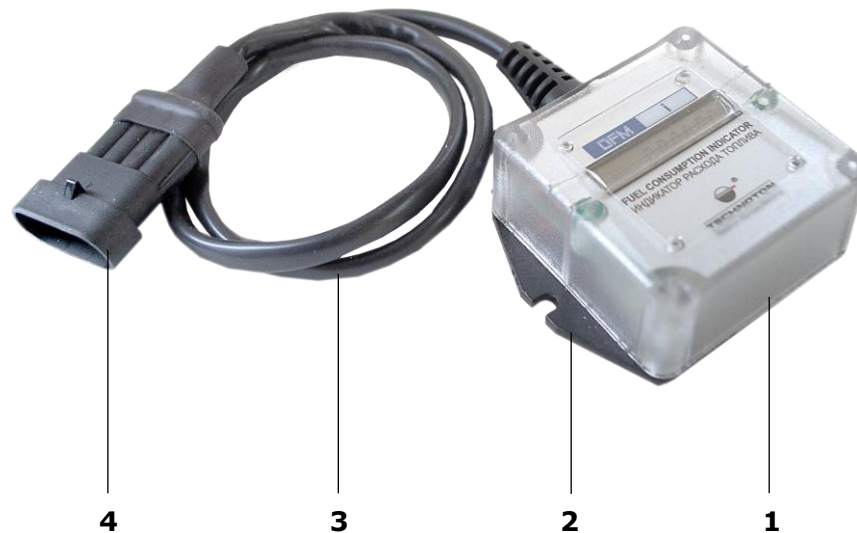

Figure 4 — Components of DFM i fuel consumption indicator

Principle of operation: DFM i is connected to the pulse output of the flow meter. Using Service DFM software the pulse value of the connected flow meter indicated in its passport is set (i.e. the value of the measured fuel volume corresponding to one output pulse of the flow meter). During the flow meter operation, the electronic module of DFM i automatically adds the fuel volume increment to the [Counter](#) accumulating the fuel volume; this increment is equal to the pulse value specified.

1.4 Technical specifications

1.4.1 Main specifications

Table 1 — DFM i main specifications

| Parameter, measuring unit | Value |
|--|-------------------------------|
| Range of fuel consumption recording, l/h | 0.5...1000 |
| Range of variation of the number of pulses per 1 l, pcs | 20...10000 |
| Power supply mode | see 1.4.3 |
| Range of external power supply voltage, V | 4...50 |
| Inbuilt power supply battery voltage, V | 3.6 |
| Impedance of input in which the measurement is taken, kOhm, no less than | 50 |
| Current consumption at 12 V / 24 V, mA, not more than | 50 / 25 |
| Ambient operation temperature range, °C | -20...+60 |
| Ingress protection rating | IP54 |
| Weight, kg, not more than | 0.3 |
| Overall dimensions | see figure 10 |

1.4.2 Input signal specifications

DFM i indicator can operate together with any flow meters whose output pulse signal meets specifications indicated in figure 5 and in table 2.

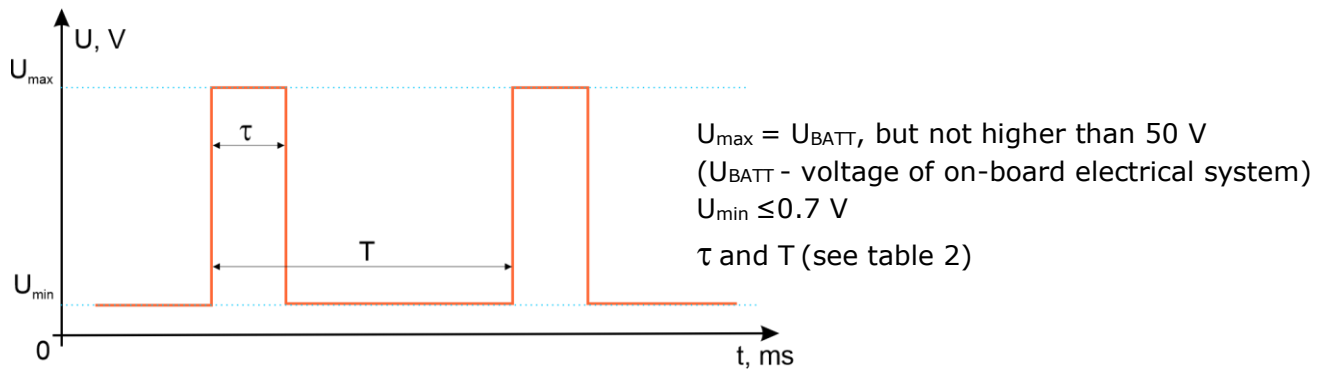

Figure 5 — Pulse input signal shape of DFM i

Table 2 — Parameters of pulse input signal of DFM i

| Period T , ms | Duration τ , ms | Pulse value, ml/pulse |
|--------------------|-------------------------|--------------------------|
| 4...9000 | (0.4...0.6) T | 0.1...50 |

1.4.3 Power supply mode

Power supply of [DFM i](#) indicator — **combined**.

DFM i can operate independently powered by the inbuilt lithium-silicone 3.6 V power supply battery without connection to the external power supply ([Vehicle](#) onboard circuit). In case connection to the onboard circuit is available, external power supply of DFM i is allowed within voltage range from 4 V to 50 V.

In case the external power supply voltage is missing or is lower than 4 V, DFM i automatically switches into the autonomous power supply mode.

Estimated DFM i service period until the inbuilt battery is fully discharged, with the onboard circuit power supply disconnected, — no less than 36 months.

1.4.4 Recording engine operation mode

Depending on the instant consumption value [DFM i](#) determines the following engine operation modes (see table 3):

- **“Idle”** – when the fuel consumer operates in the idle mode (less than 10 % of the maximum hourly fuel consumption);
- **“Optimal”** – in case of moderate load of the fuel consumer (from 10 to 75 % of its maximum hourly fuel consumption);
- **“Overload”** – in case of increased and maximum load of the fuel consumer (from 75 to 100 % of its maximum hourly fuel consumption);
- **“Tampering”** – in case of fuel consumption exceeding the maximally allowed (more than 100 % of its maximum hourly fuel consumption).

Monitoring modes of the fuel consumer operation allows to eliminate unauthorized use and downtime of the equipment, to set the efficient mode of its operation, to conduct service operations on time.

Table 3 – Modes of operation identified by DFM i

| Engine operation | | | |
|--|---|--|--------------------------------------|
| Normal consumption $0 < Q \leq Q_{\max}$ | | | “Tampering” $Q > Q_{\max}$ |
| “Idle” $0 < Q < 2.5Q_{\min}$ | “Optimal” $2.5Q_{\min} \leq Q < 0.75Q_{\max}$ | “Overload” $0.75Q_{\max} \leq Q \leq Q_{\max}$ | |
| Q — registered instant fuel consumption; Q _{min} — lower limit of recording the range of fuel consumption; Q _{max} — upper limit of recording the range of fuel consumption. | | | |



ATTENTION: Limits of modes of operation of the fuel consumer are accessible for editing using Service DFM service software (see [3.5.3](#)).

1.4.5 Displayed data

Indications of the connected flow meter and other helpful data are provided on data screens of [DFM i](#) display (see table 4); they are switched over by touching the casing cover under the display with the magnetic key for (1...2) s (see figure 6).



Figure 6 — Switching display DFM i screens

In order to save the charge of the built-in battery the DFM i display goes to sleep mode one minute after the last touch of the cover by the magnetic key. At the same time dots are shown on the display (see figure 7).



Figure 7 — DFM i display view in sleep mode

When the display is touched next time it wakes up and shows data again.

Data are shown on the display in the following way (see figure 8):

- service data are displayed during 0.5 s — screen number (on the left) and units of measurement or a comment (on the right);
- data are displayed during 1.5 s ([Counter](#) or [Parameter](#)).

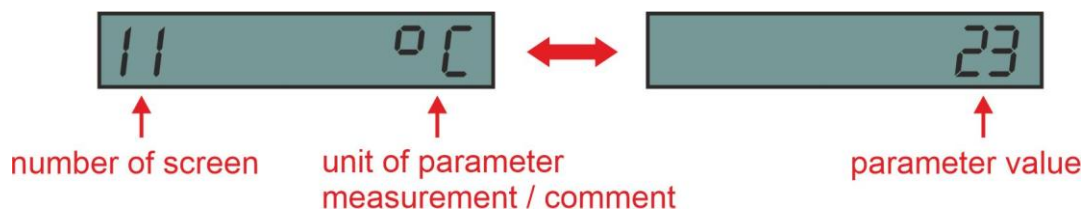

Figure 8 — Data presentation on DFM i display

Table 4 — DFM i display information screens

| Screen No | Displayed data | Digit capacity | Units |
|--|---|----------------|-------------|
| 1 | "Total Fuel Consumption" Counter | 0.1 | liters |
| 2 | "Total Fuel Consumption" Counter with higher digit capacity | 0.001 | liters |
| 3 | "Engine Operation Time" Counter | 0.1 | hours |
| 4 | "Engine Operation Time in "Idle" Mode" Counter | 0.1 | hours |
| 5 | "Engine Operation Time in "Optimal" Mode" Counter | 0.1 | hours |
| 6 | "Engine Operation Time in "Overload" Mode" Counter | 0.1 | hours |
| 7 | "Fuel Consumption in "Tampering" Mode" Counter | 0.1 | liters |
| 8 | "Instant Fuel Consumption" * | 0.1 | liters/hour |
| 9 | "Battery Charge in Percentage of the Maximum" | 10 | % |
| 10 | Temperature inside the indicator casing | 1 | °C |
| 11 | "Firmware Version" | | X.X |
| * In case of DFM i operation in combination with DFM DK differential fuel flow meter — instant differential consumption. | | | |

Screen 1 displays **"Total Fuel Consumption"** Counter value (with 0.1 liter step) accumulated since [DFM i](#) release.

Screen 2 displays **"Total Fuel Consumption value with higher digit capacity"** Counter (0.001 liter), accumulated since DFM release.

Screen 3 displays the Counter reading **"Engine Operation Time"** accumulated as the total time of engine operation in all modes including idle run.

Screens 4, 5, and 6 display the Counter readings of **"Engine Operation Time In "Idle", "Optimal" and in "Overload" Modes"** accumulated by DFM i as a total engine operation time in corresponding modes (see [1.4.4](#)).

Screen 7 displays the Counter readings of **"Fuel Consumption In "Tampering" Mode"** accumulated by DFM i measured as the amount of fuel higher than maximum consumption (see [1.4.6](#)). Value increase of this counter indicates the incorrect installation of the fuel flow meter or possible facts of fuel theft.

Screen 8 “Instant Fuel Consumption” displays the current value of the hourly consumption of fuel flowing through the measuring chamber of the flow meter connected to DFM i (in case of using single-chamber flow meter).

In case of DFM i operation in combination with [DFM DK](#) differential fuel flow meter — instant differential consumption.

It can serve for a visual check of device operability and its correct installation.

Screen 9 “Battery Charge in Percentage of the Maximum” displays the value of remaining charge of integrated battery.

Note — When the environment temperature is below 10 °C, displayed value of remaining charge can decrease by (10...30) %.

Screen 10 “Temperature inside the indicator casing” displays current inside temperature of the indicator body.

Screen 11 “Firmware Version” displays the firmware version of the indicator.

1.4.6 Protection from tampering of indications

“Tampering” mode is available in [DFM i](#) indicator providing protection from unauthorized impact on the flow meter aimed at increasing the fuel consumption Counter readings (e.g. by pumping air through flow meter).

Generally, tampering results in sharp increase of fuel consumption exceeding the maximum consumption. The electronic module of the indicator records increased consumption, sets the fuel consumption Counter to “pause” and activates “Tampering” Counter. This Counter records the volume of fuel that has passed at a higher rate through the flow meter measuring chamber. Dashes are displayed on DFM i display in “Tampering” mode. (see figure 9).



Figure 9 — Display view in “Tampering” Mode

“Tampering” mode is deactivated automatically, a few seconds after the flow meter connected to DFM i returns to the normal mode of operation.

1.4.7 Overall and mounting dimensions

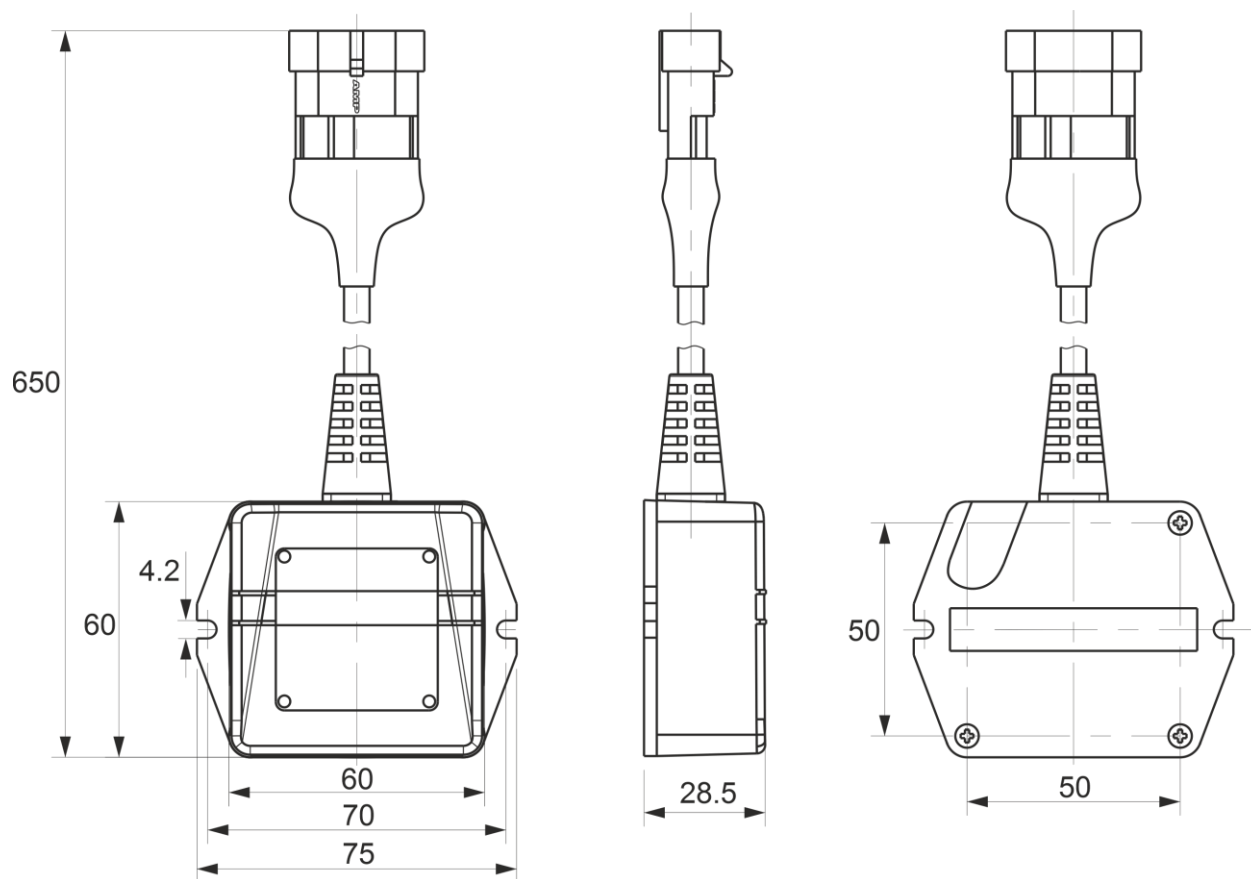

Figure 10 — Overall and mounting dimensions of DFM i

2 DFM i installation

ATTENTION:



- 1) When mounting [DFM i](#), strictly follow safety rules of car repair works as well as local safety rules of the customer' company.
- 2) Before the start, it is recommended to carefully study through the electrical circuit diagram and Operation manual for the [Vehicle](#), where DFM i is mounted.

For DFM i correct operation its mounting and configuration should be carried out by certified specialists who have passed [corporate technical training](#).

2.1 Exterior inspection prior to starting works

It is required to conduct DFM i exterior inspection for the presence of the possible defects of body, interface cable or connectors arisen during transportation, storage or careless use.

Contact the supplier if any defects are detected.

2.2 Choosing installation place

[DFM i](#) installation should be done in a dry location protected from aggressive impact of the environment. DFM i should not be mounted near heating and cooling devices (e.g. the climate control system). Also, it is not recommended to mount DFM i close to the vehicle electrical circuits.

DFM i is recommended for mounting in the driver's cabin of the [Vehicle](#) in such a way that the data screens should be located within the view of the driver. In case DFM i is mounted in the underhood space, the DFM i body and its cable have to be mounted no less than 30 sm away from the engine rotating parts and surfaces.

When mounting the indicator, we recommend to use fixing elements from the delivery set (see [1.2](#)).



Figure 11 — Example of DFM i mounting location in the tractor driver's cabin

2.3 Electrical connection



ATTENTION:

- 1) To ensure proper operation of [DFM i](#), it should be electrically connected by specialist, who finished [official technical training](#) and was certified for that.
- 2) When installing DFM i it is obligatory to follow safety rules on carrying out repair works applicable to the machinery being equipped.







DFM i is connected to the external power source (e.g. the Vehicle onboard circuit) using the **signal cable** from the [delivery set](#), in compliance with the designation of the plugs' contacts, according to table 5.

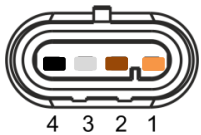

ATTENTION:

- 1) Before mounting and connecting DFM i switch off power supply of the [Vehicle](#) electrical circuits. To do this switch off the battery switch or release the terminals of the wires connected to the battery.
- 2) It is recommended to use **fuses** when connecting DFM i power supply. Nominal fuse current is not more than 2 A (purchased separately).
- 3) When connecting DFM i to onboard power source it is necessary to connect feed "+" and chassis "-" wires to the same sockets where appropriate wires of recording and display devices (trackers) are connected.
- 4) Before starting electrical connection of the DFM i special attention must be paid to the quality of the chassis ground. Resistance between any point of the chassis and the negative clamp of the battery must not exceed 1 Ohm.
- 5) It is **strongly recommended** to lay DFM i connection cable together with standard electrical vehicle wiring with mandatory cable ties fixing of every 50 cm.

Table 5 – Designation of the plugs' contacts of DFM interface cable and of those of DFM i signal cable; both are contained in the delivery set

| Connector Pinout | Connector Contact Number | Wire Marking | Wire Color* | | Circuit Designation |
|--|--------------------------|--------------|-------------|---|--|
| DFM i interface cable plug  | 1 | VBAT | Orange |  | Power "+" |
| | 2 | GND | Brown |  | Ground "-" |
| Signal cable plug  | 3 | IN | White |  | Flow meter pulse signal (see 1.4.2) |
| | 4 | KLIN** | Black |  | Digital, ISO 14230 Standard |

* [Manufacturer](#) reserves the right to modify wire colors, that is why pay attention to its markin.

** KLIN wire is missing in the signal cable.

For connecting DFM i to signal wires of [Vehicle](#), we recommend to use special **connectors** (see figure 12).

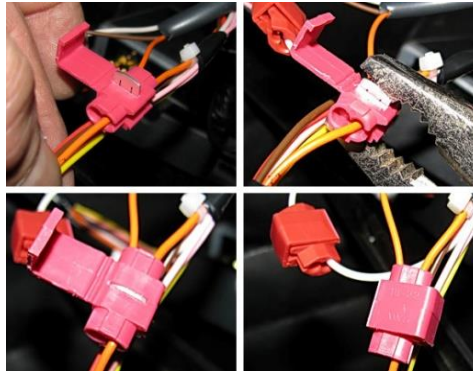
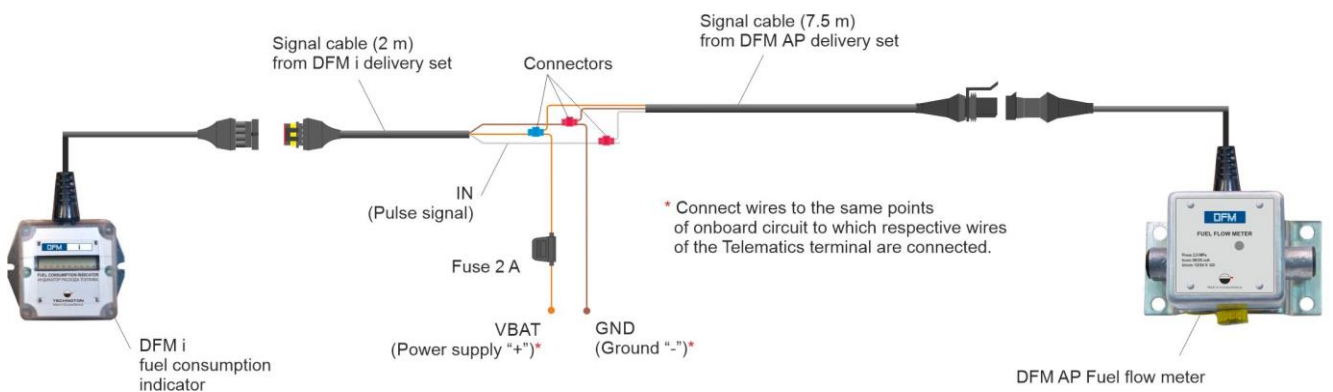
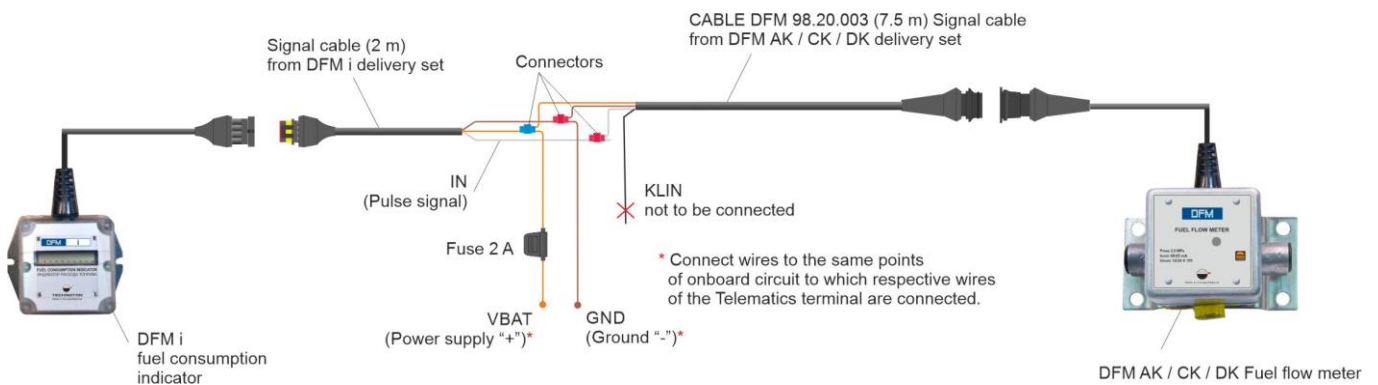

Figure 12 – Using connectors to connect signal wires

Examples of [DFM i](#) electrical connection diagrams for work in combination with [Technoton](#)-produced equipment (DFM AP/AK/CK/DK fuel flow meters and [NozzleCrocodile/Nozzle BMCrocodile](#) contactless readers) including specification of the necessary cabling are provided in figure 13.



a) connection of DFM i to DFM AP fuel flow meters



b) connection of DFM i to DFM AK/CK/DK fuel flow meters

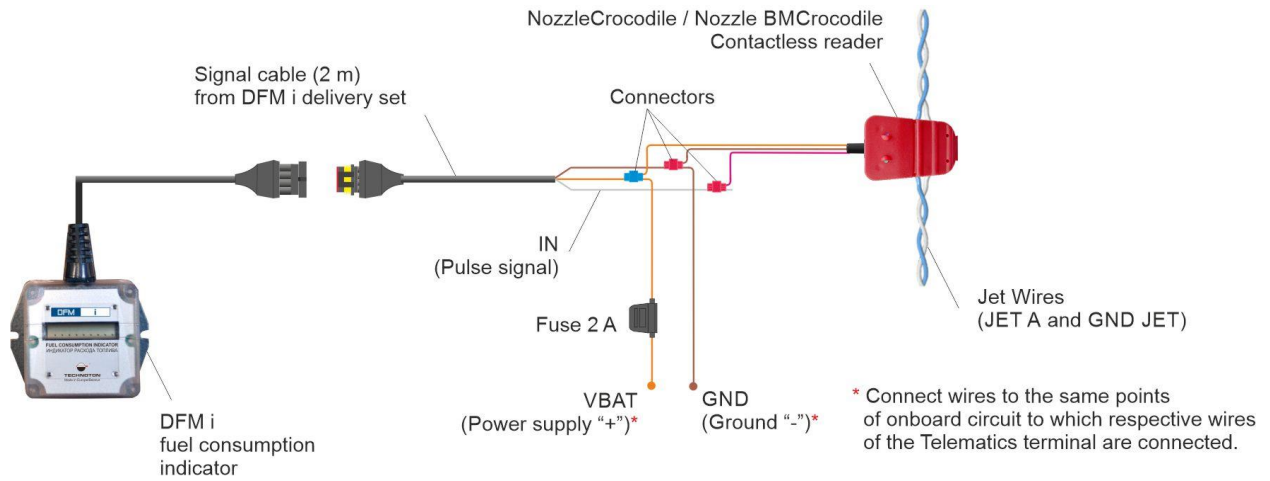

c) connection of DFM i to [NozzleCrocodile](#)/Nozzle BMCrocodile contactless reader

Figure 13 — Examples of DFM i electrical connection diagrams for work in combination with Technoton-produced equipment

3 Configuration of DFM i using the service adapter

To meet specific operational requirements, DFM i fuel consumption indicators are configured by means of K-Line (ISO 14230) service interface using **SK DFM service adapter** which is purchased separately.

Pulse fuel flow meters operating in combination with c DFM i are calibrated by their manufacturers and are supplied "ready for use". Output pulse value or the number of output signal pulses corresponding to 1 l of fuel flowing through the flow meter is indicated in their passports. Using the service adapter, the passport value of the number of pulses per 1 l is entered into the setting of DFM i pulse input (see [3.5.3](#)).

Before you start your work with the service adapter, you are to download at <https://www.jv-technoton.com/> (section [Software/Firmware](#)) and install on the PC the current version of the special software (further on — software):

- USB driver;
- Service DFM (version 4.1 and higher).

Note — Setup file has the following form: ServiceDFM_v_X_X_Setup.exe, where X_X — version of the Software.

3.1 SK DFM purpose of use

SK DFM service adapter is designed for data exchange between the PC and DFM i indicator during its configuration, viewing [Counters](#) and firmware upgrade.

Service DFM software functions:

- viewing and modifying DFM i settings;
- read indications of Counters;
- saving DFM i configuration profile to PC;
- uploading previously saved profiles to DFM i;
- print DFM i profile;
- DFM i firmware updating.

3.2 Hardware requirements

For work with Service DFM software you'll need a separate PC (desktop or laptop) on which **only** [Technoton](#) service software is installed. The PC should meet the following minimum requirements:

- Windows XP/Vista/7/8/8.1/10 operating system of X32/X64 bit depth;
- CPU — Intel Core i3, dual-core, 2.0 GHz;
- RAM — 4 Gb;
- availability of USB 2.0 port;
- display resolution 1366x768.



ATTENTION: Work with the service adapter is possible only after you install the [USB driver](#) on the PC.

3.3 Composition of the service adapter

3.3.1 Exterior view and delivery set

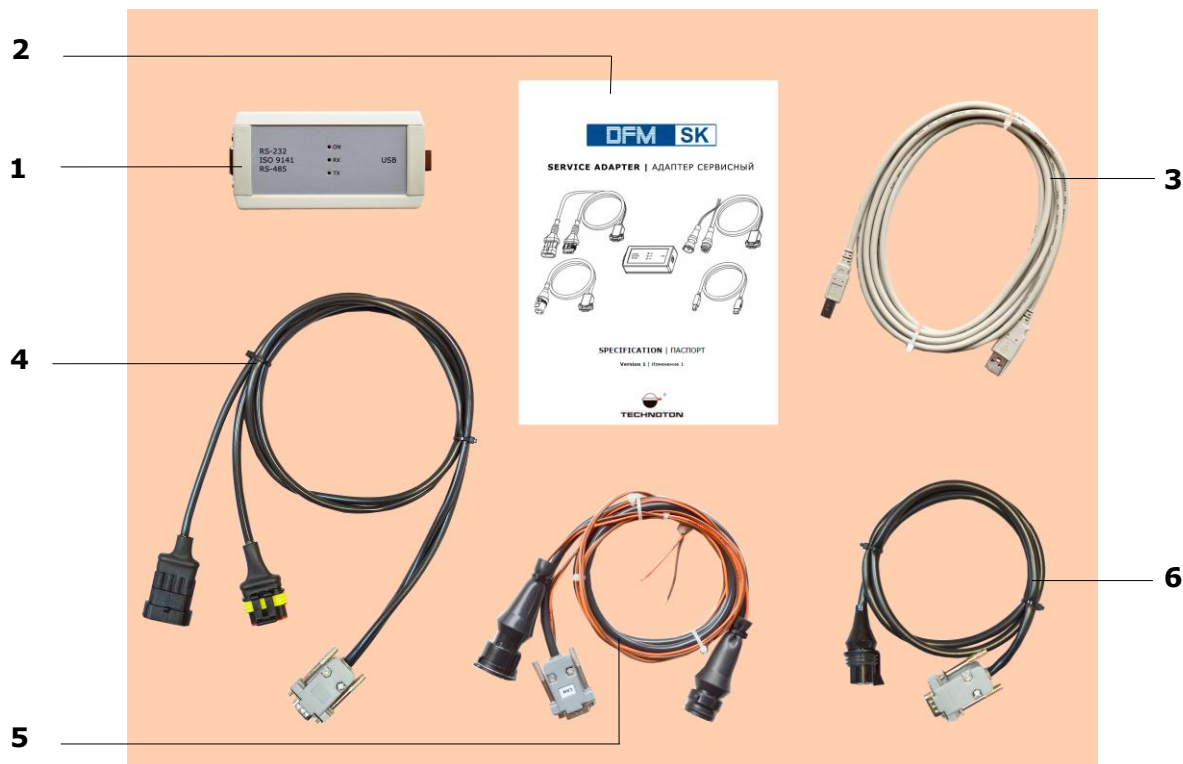

- | | |
|------------------------------------|---------|
| 1 universal service adapter | - 1 pc; |
| 2 SK DFM specification | - 1 pc; |
| 3 USB A-B cable | - 1 pc; |
| 4 DFM i service cable | - 1 pc; |
| 5 CAN service cable * | - 1 pc; |
| 6 DFM service cable * | - 1 pc. |

Figure 14 — Delivery set of SK DFM service adapter

* CAN and DFM service cables are not used during DFM i indicator configuration.

3.3.2 Universal service adapter

The universal service adapter (further on — adapter) is designed for data exchange between [DFM i](#) and PC.

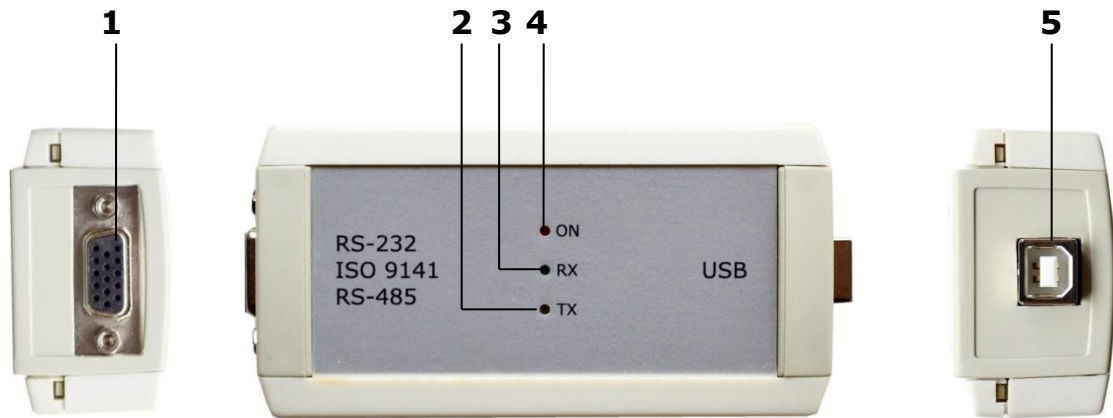

- 1** – **RS-232/ISO 9141/RS-485** socket for DFM i connection;
- 2** – **TX** yellow LED indicator of data transmitted to DFM i;
- 3** – **RX** green LED indicator of data received from DFM i;
- 4** – **ON** red LED indicator of power supply;
- 5** – **USB B** port for PC connection.

Figure 15 — External view of the universal service adapter

3.3.3 USB A-B cable

USB A-B cable is used for connection of PC and adapter.

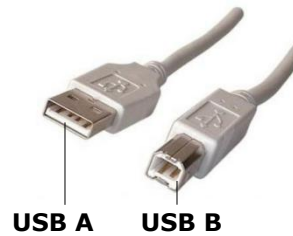
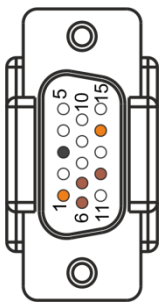





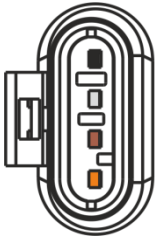



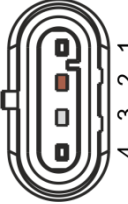



Figure 16 — USB A-B cable connectors

3.3.4 DFM i service cable

The service cable of DFM i is designed to connect the adapter to [DFM i](#) fuel consumption indicator.

Table 6 — Designation of contacts of connectors in DFM i service cable

| View | Pin No | Wire | | Signal | | |
|---|--------|----------|---|------------|------------------|------------------------------------|
| | | Marking | Color | Assignment | Type | |
|  | 1 | VBAT |  | Orange | Power "+" | Analog, Voltage 0...32 V |
| | 3 | KLIN |  | Black | K-Line | Digital, ISO14230 standard |
| | 6 | GND |  | Brown | Ground "-" | - |
| | 7 | GND |  | Brown | Ground "-" | - |
| | 12 | SEL2 |  | Brown | K-Line selection | Discrete |
| | 14 | VEE |  | Orange | Power "+" | Analog, Voltage 0...32 V |
|  | 1 | VBAT |  | Orange | Power supply | Analog, Voltage 0...32 V |
| | 2 | GND |  | Brown | Ground "-" | - |
| | 3 | PULSE IN |  | White | Pulse input | Pulse, pulse duration 0.5...500 ms |
| | 4 | KLIN |  | Black | K-Line | Digital, ISO14230 standard |
|  | 2 | GND |  | Brown | Ground "-" | - |
| | 3 | PULSE IN |  | White | Pulse input | Pulse, pulse duration 0.5...500 ms |

3.4 Service adapter connection

3.4.1 Exterior inspection prior to connection

Before the first connection of the service adapter, you are to conduct its external examination to reveal any damages caused during its shipment, storage, or careless handling:

- visible damages of the adapter body and connectors;
- connector and insulation damages of cables.

Contact the supplier if any defects detected.

3.4.2 Operation restrictions

Avoid the following when connecting service adapter to [DFM i](#), installed on the [Vehicle](#):

- ingress of fuel and lubricants and moisture to the contact pins of adapter slots or connectors of service cables;
- potential damage of the adapter and cables by the rotating and heating elements of the engine.



ATTENTION: To avoid any service adapter faults in communication between PC and DFM i make sure there are no sources of electromagnetic interference close to the workplace (running electric motors, welding equipment, high-power transformers, power lines, etc.).

3.4.3 DFM i connection to the PC



ATTENTION: Prior to connecting DFM i to a PC, it is necessary to turn off electrical circuits of the machinery unit ([Vehicle](#))*. To do this, use the battery switch or remove the battery terminals.

Connection of the DFM i for configuration is conducted in accordance with diagrams provided in figure 17.

You are to perform connection operations following the sequence below:

- 1) Using DFM i service cable, connect the interface cable plug of DFM i fuel consumption indicator (see [3.3.4](#)) to **RS-232/ISO 9141/RS-485** plug of the adapter (see [3.3.2](#)).
- 2) Connect the adapter using USB A-B cable to a free USB-port of your PC.

Note — Adapter can also be connected to USB-port of your PC after turning Vehicle's electrical system ON and starting the software.

- 3) Connect power supply wires to Vehicle onboard power network or power supply unit.

Notes

1 During the configuration of DFM i power is supplied from the PC USB-port via USB A-B cable. The adapter is ready for operation from the moment power is supplied from the PC USB-port.

2 If you need to check the correctness of data display in different modes of fuel consumption, you must provide the external power supply for the flow meter that operates in combination with DFM i.

- 4) Switch power on (battery).

Immediately after the adapter connection to the PC, the red LED **ON** indicator of power supply is lit on the front panel. In case DFM i is not connected to the adapter or the software is not activated, this indicator goes off after 15 s.

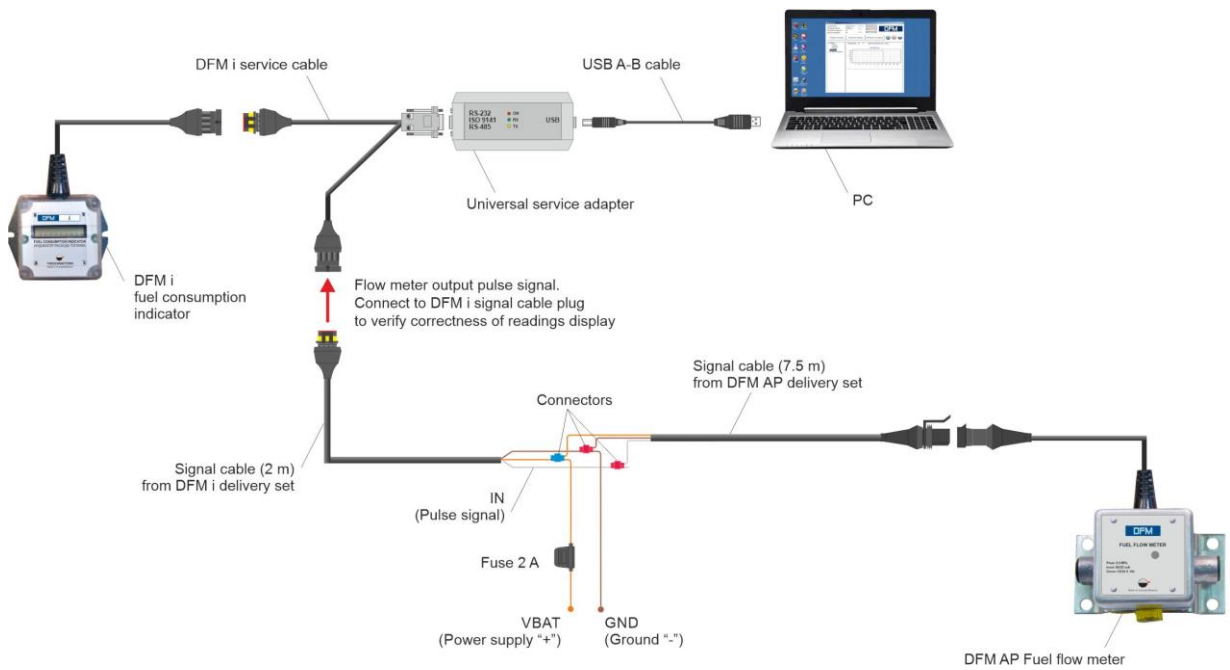

a) during DFM i operation together with DFM AP fuel flow meter

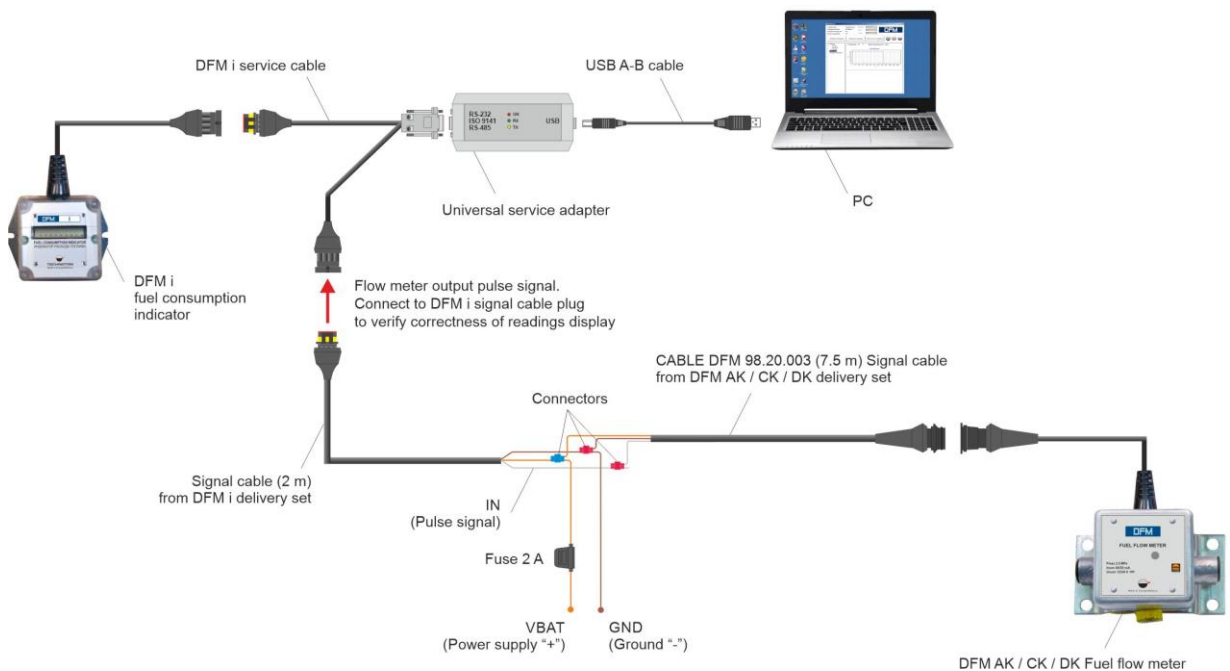

b) during DFM i operation together with DFM AK / CK / DK fuel flow meter

Figure 17 — Examples of DFM i connection diagrams to connect it to the PC with SK DFM

3.5 Service DFM software operation

3.5.1 User interface



Service DFM software is launched with a  label which is created during the installation process. User interface consists of **Horizontal menu**, **Vertical menu**, **Connection Status area** and **Information and configuration area** (see figure 18).

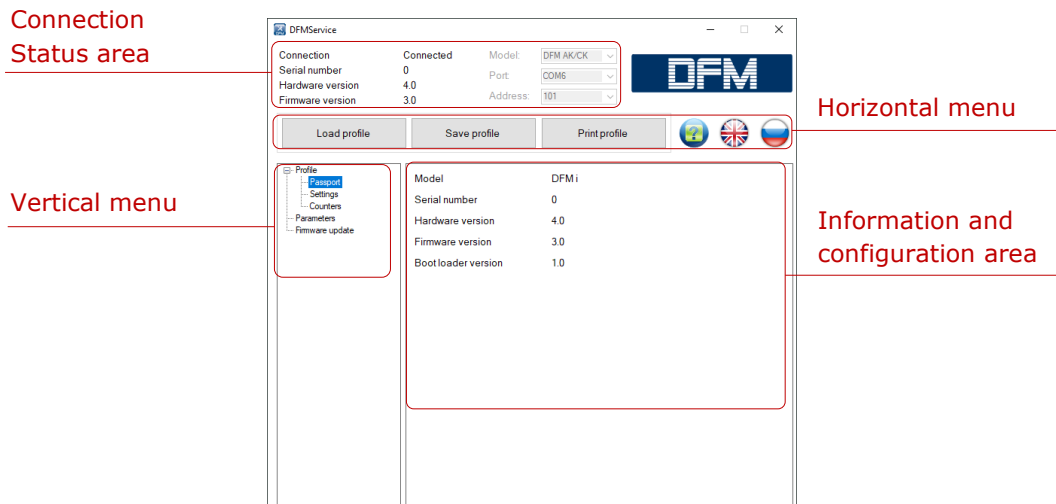

Figure 18 — Service DFM software user interface

In **Connection status** area data on the current connection status of DFM i and the PC (On/Off), the serial number, hardware version and firmware version of the connected indicator are displayed.

Horizontal menu provides following options:

- selection of operations with the indicator profile (loading profile, saving profile, printing profile);
- selection of interface language;
- viewing help file and information about the software.

Vertical menu is used to select elements of the indicator profile which are displayed in **Information and settings** area; it also enables you to conduct the indicator functioning check and to update its firmware.

Preparation for work with software includes the following operations:

- identification and selection of the virtual COM-port number of the PC;
- selection of the software interface language.



ATTENTION: Number of the virtual COM-port may be identified only when the following conditions are met:

- 1) USB driver is installed in the PC.
- 2) The adapter must be connected to the USB-port of the PC.

As soon as Service DFM software is started, with no adapter connected to the PC USB-port, the error message of opening the virtual COM-port appears (see figure 19).

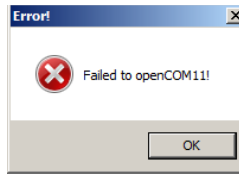
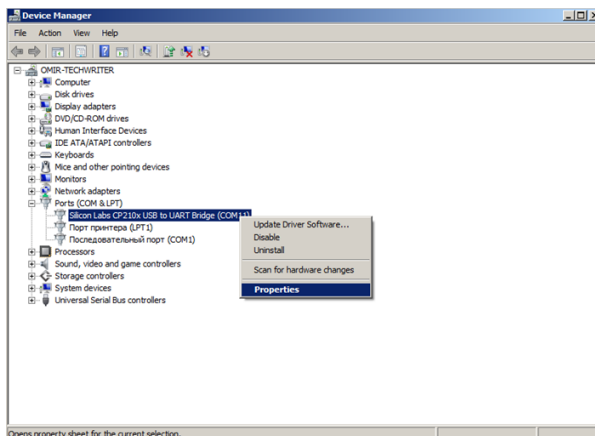

Figure 19 — Error message of opening COM-port

Windows automatically detects adapter connected to PC's USB port as USB device and enables virtual COM port driver for it. The virtual COM port will be displayed in the list of ports of Windows Device manager. To open it, press Win+X keys combination and start the Media Device Manager in the window that is opened (see figure 20).



ATTENTION: To work with Service DFM it is recommended untick power save check box in virtual COM-port properties.



a) selecting port properties

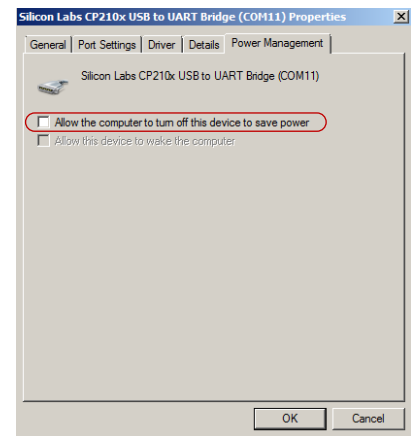

b) disabling power save option

Figure 20 — Virtual COM-port configuration in Device manager

After the number of the virtual COM-port is identified, you are to choose it in the software from **Port** dropdown list (see figure 21).

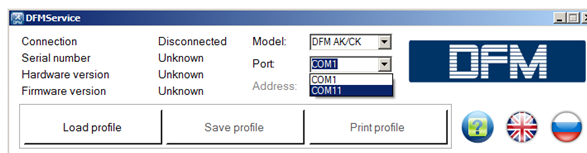

Figure 21 — Virtual COM port selection

The language of the interface of Service DFM software is selected by pressing one of the buttons with flags of countries corresponding to the interface language; after that, the software is automatically restarted.



ATTENTION: The selected number of the virtual COM-port and the language of the interface are stored in the configuration file of Service DFM software. You won't have to select them again during next sessions of work with the software.

3.5.2 Working with DFM i profile

DFM i profile is the total of the indicator passport data, settings and [Counters](#).

Service DFM software allows to work both with the profile of the connected indicator, and in the independent mode. During work in the independent mode loading and work with files of earlier saved profiles is possible.



ATTENTION: In this Operation manual, the operation of Service DFM software is described for the case, when the indicator is connected. In case the indicator operates in the independent mode, certain parameters and functions of the software are inaccessible.

Profile can be stored as a file to PC hard drive or loaded into the memory of the indicator. It can be printed as well.

The following operations with the indicator profile are available:

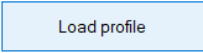
1) Loading profile. To load [DFM i](#) profile, press  button in **Horizontal menu**. The following options of loading the profile are offered (see figure 22):

- **Load profile from file** — for loading of previously saved profile from the hard drive or removable disk. Select the **(* .prf)** file of the indicator profile in the appeared open window.
- **Load default profile** — is used for loading profile with default factory settings. With this profile it is possible to study utility operation without real DFM i connection.
- **Load profile from device** — used for loading profile from the connected indicator.

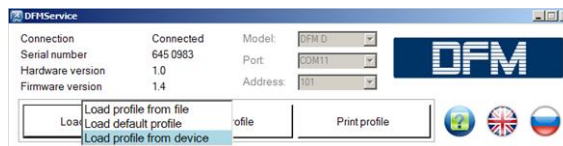
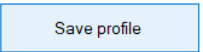

Figure 22 — DFM i profile loading

2) Saving profile. To save changes in DFM i profile, press  button in **Horizontal menu**. The following options of saving the profile are offered (see figure 23):

- **Save profile to file** — is used to save the profile on the hard disc or on detachable media. Choose the file location on the disc in the window that opens and assign a file name to the profile file **(* .prf)**. The saved profile can be loaded to other connected DFM i.
- **Save profile to device** — is used to save changes of the profile settings in the memory of the connected indicator.

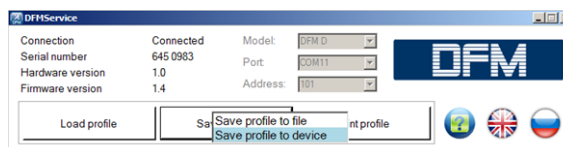
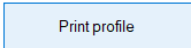

Figure 23 — DFM i profile saving

3) Print profile. To print [DFM i](#) profile, press  button in **Horizontal menu**. In **Print** window that opens you may select the printer and configure printing parameters, if necessary (see figure 24).

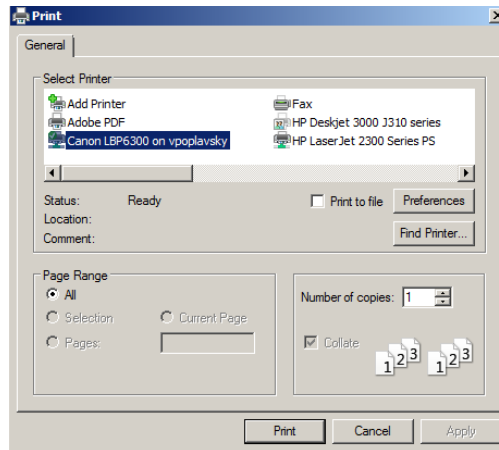

Figure 24 — Window of configuration of DFM i profile printing



RECOMMENDATION: The printed copy will contain flow meter profile data as well as the date when it been printed. It is recommended to attach the hardcopy of the profile to the meter's specification to log the history of the settings and configurations.

3.5.3 Adapting indicator to operational conditions

For correct display of indications, you are to configure [DFM i](#) for specific operational conditions (**Settings** submenu) (see figure 25):

The following indicator settings are available:

- **Input** — field to configure the pulse input in which you are to specify the passport value of the number of output pulses per 1 l for the flow meter operating together with DFM i indicator which is being configured. The allowed range of values that can be specified: 20...10000 pulses/l.

Notes

1 The fuel volume value which is equal to the rated volume of its measuring chamber corresponds to 1 output pulse of fuel of the flow meter (pulse value). The size of the pulse value or the number of output signal pulses per 1 l is generally indicated in the passport of a specific flow meter.

2 In case NozzleCrocodile or Nozzle BMCrocodile is used in combination with DFM i, you are to enter the value of the calibration coefficient for a specific vehicle in the field **Input** (see the calibration procedure in [Crocodile contactless readers operation manual](#)).

- **The boundaries of modes** — fields to specify limits of fuel consumption modes of the monitored engine, depending on the hourly fuel consumption (see [table 3](#)):
 - «**Idle**» – fuel consumption of less than 10 % of the maximum hourly fuel consumption;
 - «**Optimal**» – fuel consumption from 10 to 75 % of the maximum hourly fuel consumption;
 - «**Overload**» – fuel consumption from 75 to 100 % of the maximum hourly fuel consumption.

Values of the hourly fuel consumption in different fuel consumption modes for a specific engine can be found in its technical documentation or defined experimentally.

Monitoring modes of the engine operation allows to take into account the actual wear, to eliminate diversion of the equipment from its dedicated use or its idling, to monitor the economical mode of operation and to conduct servicing on time.

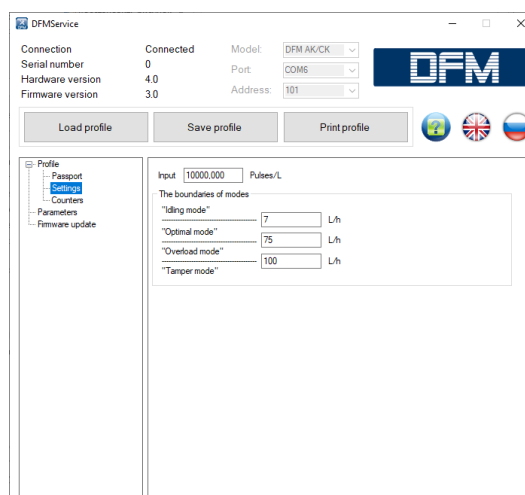

Figure 25 — Example of pulse input settings configuration and limits of operation modes of DFM i indicator

3.5.4 Reading indications of Counters

Counters submenu is convenient for use to take readings of fuel consumption [Counters](#) and time of operation of the monitored engine (see figure 26):

- **Total consumption** — total fuel consumption by the [Vehicle](#) within the whole range of loads including "Idle" mode of operation.
- **Total time** — counts the total time of the Vehicle engine operation within the whole range of loads including "Idle" mode of operation.
- **Consumption in "Idling mode"** — total fuel consumption by the Vehicle in "Idle" mode of operation.
- **Time in "Idling mode"** — total time of the Vehicle engine operation in "Idle" mode of operation.
- **Consumption in "Optimal mode"** — total fuel consumption by the Vehicle in "Optimal" mode of operation.
- **Time in "Optimal mode"** — total time of the Vehicle engine operation in "Optimal" mode of operation.
- **Consumption in "Overload mode"** — total fuel consumption by the Vehicle in "Overload" mode of operation.
- **Time in "Overload mode"** — total time of the Vehicle engine operation in "Overload" mode of operation.
- **Consumption in "Tamper mode"** — total fuel consumption by the Vehicle which exceeded the upper admissible limit for the used model of the flow meter.
Increased indication of this counter is a sign of the flow meter incorrect mounting or of possible facts of fuel discharge.
- **Time in "Tamper mode"** — total time during which exceeding of the upper admissible fuel consumption limit for the model of the used flow meter took place.
- **Operating time** — total operation time of the flow meter measuring chamber since the moment of its manufacturing.

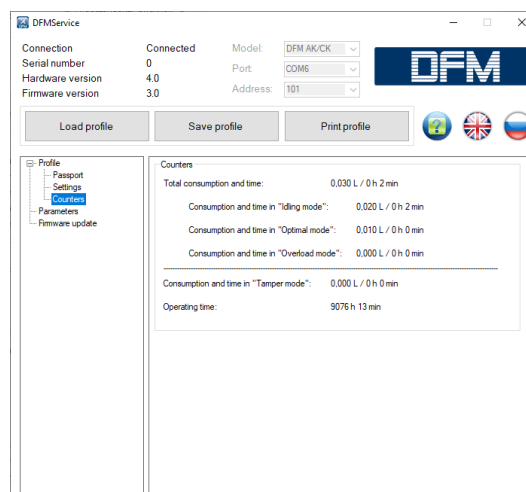

Figure 26 — Example of displaying readings of Counters accumulated in the memory of DFM i indicator



IMPORTANT: It should be taken into account that during DFM i operation, the update of values of the indicator internal Counters displayed in **Counters** submenu takes place only once in 6 min. Therefore, we do not recommend to use data from the internal Counters during monitoring accuracy of measurements of the connected flow meter.

During the calibration test it is allowed to use readings of Counters displayed on information screens of DFM i (see [1.4.5](#)).

3.5.5 Operation check

To check [DFM i](#) functioning together with the connected flow meter, **Parameters** submenu is used.

In **Instant consumption** area, the green graph of instant fuel consumption flowing through the flow meter measuring chamber is displayed in real time (see figure 27).

The **Interference sensor** parameter dedicated to detect the impact of external factors on the flow meter hampering its operation is not relevant for DFM i indicator and is always in **Off** position.

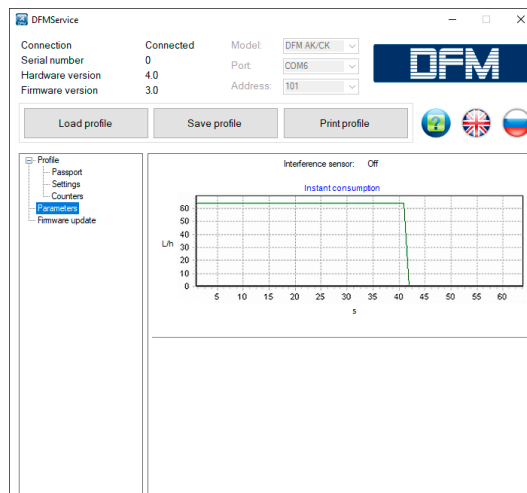

Figure 27 — Example of displaying the graph of instant consumption of fuel passing through the flow meter measuring chamber in Parameters submenu

3.5.6 Firmware upgrade

Firmware update submenu (see figure 28) is used to update the inbuilt software (firmware) of DFM i.

IMPORTANT: DFM i firmware update should be done **only** for implementation of improvements, recommended by [Manufacturer](#).



Before the firmware update, study the instructions attached to the firmware file and make sure it matches the hardware version of the indicator firmware to be updated.

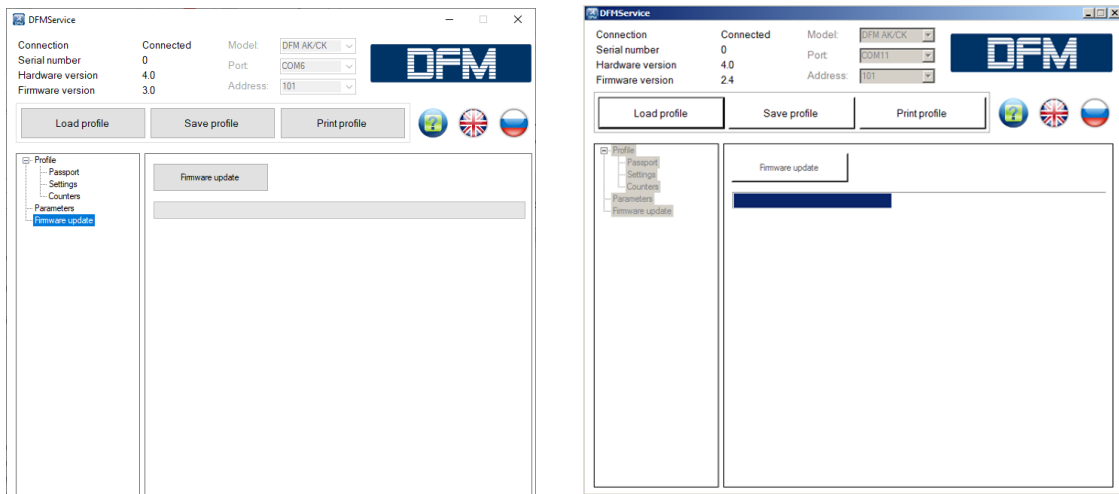
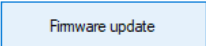
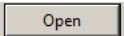

Figure 28 — Loading the updated software into DFM i

To upgrade DFM i firmware the following actions should be made:

- 1) Press  button.
- 2) Select the firmware file (***.cod**) on the PC disc or on the detachable media.
- 3) By pressing  button, start the firmware update procedure.

ATTENTION: Before the end of loading data into DFM i and automatic reload of Service DFM software, it is forbidden to:



- Disconnect DFM i from the adapter.
- Disconnect the adapter from the PC.
- Switch off the PC power supply.
- Run resource-heavy software on the PC.

In case the firmware update is successful, the new firmware version will be displayed in **Connection status** area of DFM Service software. DFM i indicator will be ready for further operation.

In case the firmware update procedure was completed incorrectly which resulted in the flow meter non-serviceable state, you have to go through the **emergency firmware update** procedure in the following way:

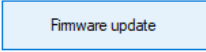
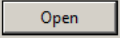
- 1) Close Service DFM software and disconnect the indicator interface cable from DFM i service cable.
- 2) Start Service DFM software and load DFM i profile from the file.
- 3) Open **Firmware update** submenu and press  button. Select the firmware file (***.cod**) in the opened window and start the procedure of data loading into DFM i by pressing  button.
- 4) Connect the service cable of DFM i to the interface cable plug and wait until the procedure of loading data into DFM i is completed.

In case the emergency firmware update is a success, after the automatic reboot, the indicator will be ready for operation again. If the emergency firmware update of the indicator also fails, we recommend to contact [Technoton technical support](#) by e-mail: support@jv-technoton.com.

3.5.7 Completion of the working session with the software and switching off the indicator

To complete the working session with [DFM i](#) indicator, you are to perform operations in the following sequence:

- 1) Save changes made during your work (see [3.5.2](#)).
- 2) Close Service DFM software by pressing  in the upper portion of the software window.
- 3) Disconnect DFM i service cable from the plug of the interface cable.

4 Packaging

[DFM i](#) delivery sets come in cardboard boxes of the following shape (figure 29).



Figure 29 — Packaging of DFM i fuel consumption indicator

Label sticker with information on the product name, certificates, serial number, firmware version, manufacture date, weight as well as Quality Control seal and QR code is stuck on two sides of the DFM i box (see figure 30).



Figure 30 — Packaging label of DFM i fuel consumption indicator

Note — Label design and contents can be modified by the [Manufacturer](#).

5 Storage

[DFM i](#) is recommended to be stored in dry enclosed areas.

DFM i storage is allowed only in original packaging at temperature range from -50 to +40 °C and relative humidity up to 100 % at 25 °C.

Do not store DFM i in the same room with substances that cause metal corrosion and/or contain aggressive impurities.

DFM i shelf life must not exceed 24 months.

6 Transportation

Transportation of [DFM i](#) is recommended in closed transport that provides protection from mechanical damage and precipitation.

When transporting by air, DFM i must be stored in heated pressurized compartments.

Air environment in transportation compartments should not contain acid, alkaline and other aggressive impurities.

Shipping containers with packed DFM i should be sealed.

7 Utilization/re-cycling

[DFM i](#) does not contain precious metals in amount that should be recorded.

The inbuilt lithium-thionyl chloride battery of DFM i contains harmful substances and components that are hazardous to human health and environment.

Battery must not be disposed of together with general domestic waste.

The Buyer is responsible for the disposal of battery by means of its delivery to the hazardous waste collecting center; this will ensure safety for human health and environment.

[Technoton](#) bears no responsibility for any non-compliance with the above disposal and recycling requirements for battery.

Contacts

Distribution, technical support and service



sales@jv-technoton.com

support@jv-technoton.com



Annex A

Videography

1) DFM Marine Fuel Flow Meter video.

Link:  https://www.youtube.com/watch?v=9IC4_RzfLik

2) DFM Fuel Flow Meter Installation video (DFM installation on tractor. After pump (pressure side) scheme).

Link:  <https://www.youtube.com/watch?v=ATscYhBsD3c>

3) DFM fuel flow meter operation principle video (fuel flow measurement principle of DFM measuring chamber).

Link:  <https://www.youtube.com/watch?v=RXjvwyy1zIY>

4) Interactive flash animation Fuel Consumption Monitoring. DFM Fuel Flow Meter

Link:  <https://www.youtube.com/watch?v=IOCQCNgGG7Uf>

5) Interactive animation video DFM fuel flow meter: selection of mounting scheme, accessories and mounting kit

Link: [DFM fuel flow meters: selection of installation layout, accessories and mounting kit](#)

6) Check out YouTube channel for other Technoton videos at:

 <https://www.youtube.com/channel/UCq7EF3DHrgl7fOWB2ynsR-A>