

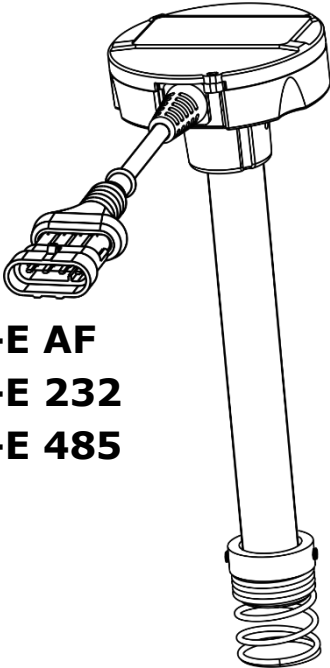

FUEL LEVEL SENSORS



DUT-E AF
DUT-E 232
DUT-E 485



DUT-E A5
DUT-E A10
DUT-E F
DUT-E I

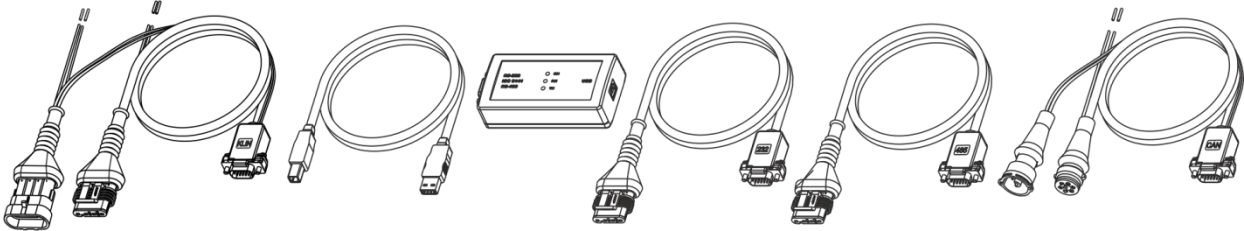

SK DUT-E service adapter

OPERATION MANUAL

(includes Service DUT-E software manuals)

Version 9.0



TECHNOTON
ADVANCED MACHINERY TELEMATICS

Contents

Revision history	4
Structure of external links	5
Terms and Definitions	6
Introduction	7
1 General information and technical specifications	9
1.1 Purpose of use and application area	9
1.2 Exterior view and delivery set	11
1.3 Design and operation principle	12
1.4 Technical specifications	14
1.4.1 Main specifications	14
1.4.2 Specifications of DUT-E AF output signal	15
1.4.3 Specifications of DUT-E A5/A10/F/I output signal	16
1.4.4 Specifications of DUT-E 232/485 output signal	17
1.4.5 Compatibility with Terminals and receiving devices	18
1.4.6 Overall dimensions	19
2 DUT-E installation	20
2.1 Exterior inspection prior to works start	20
2.2 General recommendations for sensor installation	21
2.2.1 Standard fuel sensor replacement	21
2.2.2 Installation into a special hole	22
2.2.3 Probe cutting according to tank depth	25
2.2.4 Length extension	26
2.2.5 Mounting a screen filter and fixing the sensor	27
2.3 Electrical connection	29
2.3.1 Electrical connection of DUT-E AF	31
2.3.2 Electrical connection of DUT-E 232/485	32
2.7.3 Electrical connection of DUT-E A5/A10/F/I	33
2.4 Monitoring of two and more tanks	34
2.4.1 DUT-E 232 readings totalizing	34
2.4.2 DUT-E AF readings totalizing	37
2.5 Sealing	40
3 Configuration of sensor using service adapter	41
3.1 SK DUT-E purpose of use	41
3.2 Hardware requirements	42
3.3 Service adapter components	43
3.3.1 Exterior view and delivery set	43
3.3.2 Universal service adapter	44
3.3.3 USB A-B Cable	45
3.3.4 RS-485 service cable	46
3.3.5 RS-232 service cable	47
3.3.6 AF service cable	48
3.3.7 CAN service cable	49
3.4 Software installation	50
3.4.1 USB driver installation	50
3.4.2 Service DUT-E software installation	51
3.5 Service adapter connection	52
3.5.1 Exterior inspection prior to connection	52
3.5.2 Operation restrictions	53
3.5.3 Connecting DUT-E to PC	54
3.6 Operation test	56
3.7 Software launch	57
3.8 User interface and initial setup	58

3.9 Operations with DUT-E profile.....	59
3.9.1 Load profile	59
3.9.2 Save profile	60
3.9.3 Print profile	61
3.10 Vertical menu description	62
3.10.1 Passport.....	62
3.10.2 Authorization	63
3.10.3 Settings - Calibration	65
3.10.4 Settings – Operation modes.....	66
3.10.5 Settings – Thermal compensation.....	67
3.10.6 Settings – Output message.....	68
3.10.7 Settings – Calibration table.....	69
3.10.8 Settings - Interface	71
3.10.9 Settings – Analog output.....	72
3.10.10 Diagnostics	74
3.11 Firmware update.....	76
3.12 Software shutdown and DUT-E disconnection.....	78
4 Measurement accuracy check	79
4.1 Basic principles.....	79
4.2 Check tests procedure	80
5 Accessories	81
5.1 MK DUT-E mounting kit	81
5.2 Connection cables	82
5.4 Additional accessories.....	83
6 Diagnostics and troubleshooting	84
6.1 DUT-E with analog output	84
6.2 DUT-E with frequency output.....	85
6.3 DUT-E with digital output.....	86
7 Maintenance.....	87
7.1 General instructions	87
7.2 Demounting	88
7.3 Examination	89
7.4 Cleaning	90
8 Packaging	91
9 Storage	92
10 Transportation	93
11 Utilization/re-cycling.....	94
Contacts.....	95
Annex A Template of check test report	96
Annex B Method of recording the calibration table for tanks of great capacity.....	97
Annex C DUT-E profile printed copy	98
Annex D DUT-E log file example	99
Annex E Electromagnetic compatibility specifications of DUT-E	100
Annex F ASCII text data transfer protocol for DUT-E 232/485	101
Annex G Videography.....	103

Revision history

Version	Date	Editor	Description of changes
1.0	01.2007		Basic version.
7.0	04.2016	OD	<ul style="list-style-type: none"> • New design of measurement head of DUT-E. • Changes in delivery set of DUT-E, MK DUT-E. • Addition and updates to description of installation of DUT-E. • Changes in description of Service software. • New packaging of DUT-E. • Methodology of thermal correction coefficient calculation added. • International certificates ISO 9001:2015 (DaKKs) and Customs Union added.
8.0	01.2017	OD	<ul style="list-style-type: none"> • Instructions on S6 SK operation while configuring DUT-E CAN added. • Schemes of connection of DUT-E CAN to PC via S6 SK added (including scheme of sensors for configuration within S6 interface). • Terminology updated. • Operation instructions for software Service DUT-E updated. • New accessories for DUT-E added.
8.1	02.2020	OD	<ol style="list-style-type: none"> 1) Updated: <ul style="list-style-type: none"> - currently valid certificates; - composition of DUT-E and MK DUT-E delivery sets; - diagrams of sensors connection to the PC with S6 SK service adapter; - minimum requirements for PC for work with Service DUT-E software; - examples of diagrams of DUT-E CAN connection to the Telematics terminal; - document terminology. 2) Information added on: <ul style="list-style-type: none"> - sensors models codes; - sensors electromagnetic compatibility; - taking into account the dead zone while creating the tank calibration table; - additional sensors accessories. 3) The structure of the document external links is introduced.
8.2	05.2021	OD	<ol style="list-style-type: none"> 1) Information on the transfer of data of DUT-E 232/485, according to ASCII protocol, is added. 2) Added specifications regarding tightening threaded connections of KDC additional sections in case of the sensors' length extension. 3) US-1 adapter unit is removed from the sensor accessories list.
9.0	05.2023	OD	<ol style="list-style-type: none"> 1) Model DUT-E CAN (model code 116) deleted. 2) The certificates are updated. 3) Information on the product is added. 4) Recommendations regarding creation of a calibration table for a tank of volume greater than 6553 l are added. 5) Method of calculation of thermal correction coefficient is improved etc.

Structure of external links

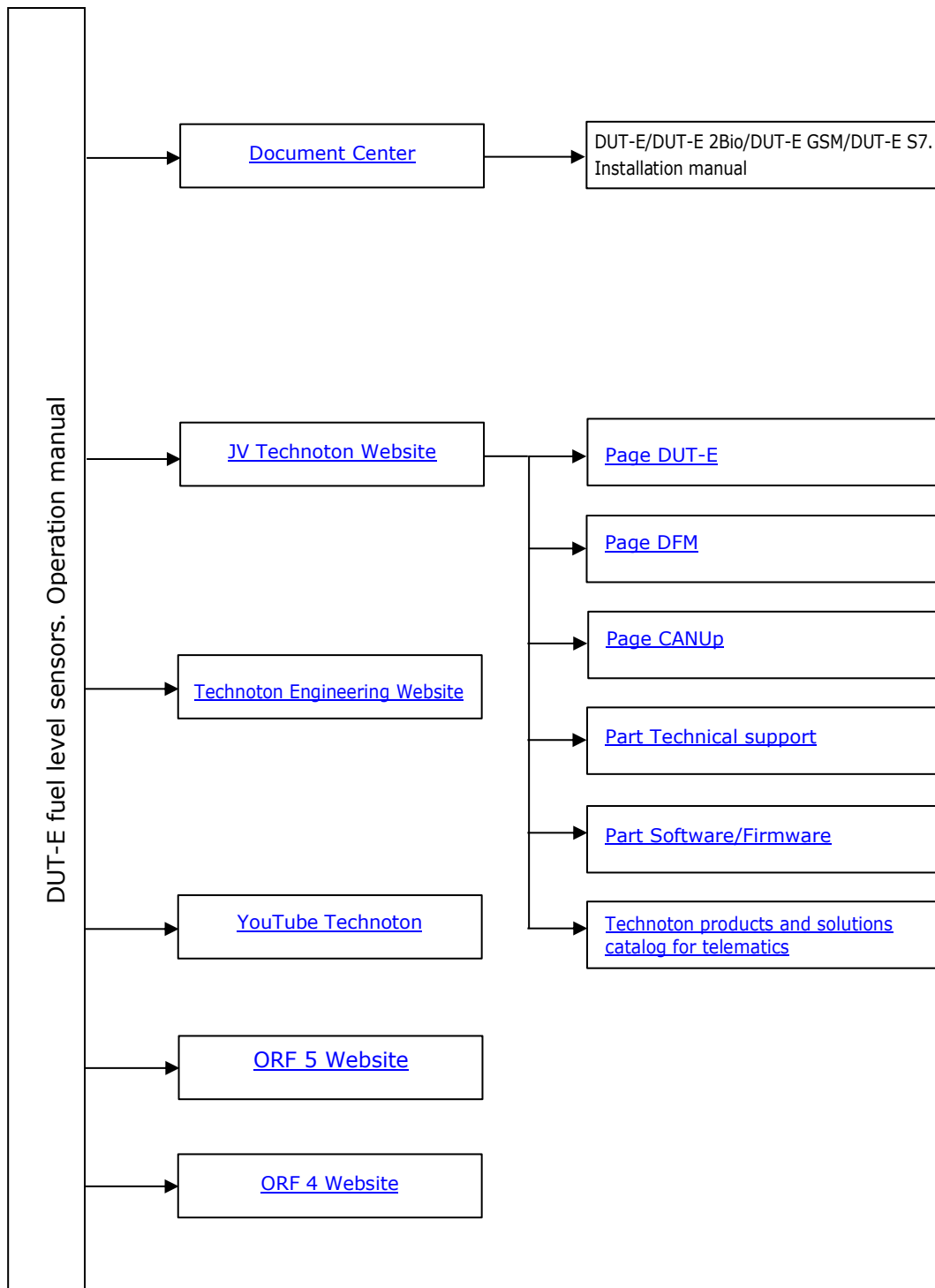

Terms and Definitions

ORF 4 / ORF 5 — [Technoton](#)-designed Telematics services dedicated to reception of Onboard reports via Internet channels, their processing and displaying operational data in the browser against the background of the terrain map; they- are also designed for data accumulation in the database, generation of Analytical reports upon user requests.

Analytical report — report generated in ORF 4 / ORF 5 on vehicle or group of vehicles operation for chosen time period (usually a day, week or month). Can be composed of numbers, tables, charts, mapped route of vehicle, diagrams.

Counter — cumulative numerical characteristic of Parameter. Counter is displayed by a single number and over time its value is increasing. Examples of counters: fuel consumption, trip, engine hours counter etc.

Event — a relatively rare and sudden change in SPN. For example, the sharp increase of volume in the tank is the Event «Fuelling». An Event may have one or more characteristics. Thus, the Event «Fuelling» has the following characteristics: «volume of fuel at the beginning of the fuelling», «volume of fuel at the end of the fuelling», «volume of the fuelling» and so on. As soon as an Event is detected, the Terminal registers the time of the Event which is subsequently specified in the Report of the Event. The Event is always linked to the time and the location where it was detected.

GNSS (Global Navigation Satellite System) — System for area positioning of an object through satellite signal processing. GNSS is composed of space, ground and user segments. Currently, there are several GNSSs: GPS, GLONASS, Galileo, BeiDou.

Model code — digits designating the product modification. For DUT-E sensors, the model code is identified by the first three digits of its serial number placed on its measuring probe and on its packing label.

Onboard equipment (OE) — Telematics system elements, directly installed in Vehicle.

Onboard reports (the Reports) — information about vehicle which is returned to a user of Telematics system in accordance with inputted criteria. The Reports are generated by a terminal unit both periodically (Periodic reports) and on Event occurrence (Event report).

Parameter — time - varying or space characteristic of the Vehicle (SPN value). For example, speed, fuel volume in the tank, hourly fuel consumption, coordinates. Parameter is usually displayed in the form of graph, or averaged data.

Server (AVL Server) — hardware-software complex of Telematics service ORF 4 / ORF 5, used for processing and storage of Operational data, formation and transmission of Analytical reports through Internet by request of ORF 4 / ORF 5 users.

Telematics system — complex solution for vehicle monitoring in real time and trip analysis. The main monitored characteristics of the vehicle: Route, Fuel consumption, Working time, technical integrity, Safety. In includes On-board report, Communication channels, Telematics service ORF 4 / ORF 5.

Telematics terminal (Tracking device, Telematics unit) is a unit of Telematics system used for reading the signals of Vehicle standard and additional sensors, getting location data and transmitting the data to the Server.

During the use of DUT-E GSM fuel level sensor within the Telematics system the Terminal is not required.

Vehicle is an object controlled by the Vehicle Tracking System. This is generally a truck, a bus or a tractor, sometimes a locomotive, a ship, a utility vehicle. From the point of view of Vehicle Tracking System, static equipment such as diesel generators, heating boilers, burners, and so on are considered vehicles.

Introduction

Recommendations and rules set out in this Operation Manual apply to **DUT-E fuel level sensors** (further on — [DUT-E](#)), models codes: **111** (for DUT-E 232), **115** (for DUT-E 485), **112** (for DUT-E A5), **113** (for DUT-E A10), **114** (for DUT-E F), **124** (for DUT-E AF), **068** (for DUT-E I) and [SK DUT-E service adapter](#) (further on — SK DUT-E) manufactured by [Technoton](#) company.

The model code of DUT-E is identified by the first three digits of its serial number printed at its measuring probe or on its packing label:



The manual contains information on design, operation principle, specifications and instructions on installation, use and maintenance of DUT-E. The manual defines SK DUT-E connection and usage guidelines as well as [Service DUT-E](#) software (version 3.26 and higher) installation and use.

DUT-E are additional sensors within [Telematics systems](#). **DUT-E sensors are used for accurate level measurement in fuel tanks of vehicles and stationary units.** **SK DUT-E serves for data exchange between the sensor and the personal computer.**

DUT-E key features:

- adjustable temperature correction for automatic measurement correction based on ambient temperature*;
- automatic compensation of ambient temperature impact on the electronic module in the sensor "head"*;
- function of digital self-diagnostics for sensor quality control*;
- measuring probe length extension up to 6 m with additional sections*;
- measuring probe length reduction without min/max recalibration**;
- summation of fuel volume values in several tanks (up to 8 pcs.) using [DUT-E SUM](#) AF/232 summator (purchased separately)***;
- built-in voltage stabilizer – output signal does not depend on vehicle power supply voltage;
- reverse polarity and short circuit protection of any output to vehicle electrical system and chassis;
- ergonomic bayonet mount allows to save installation time;
- screen filter (purchased separately) for secure protection from water and mud;
- bottom spring for better mounting rigidity;
- full set of mounting accessories and connection cable included;
- sealing possibility to avoid unauthorized intrusion and tampering;
- conformity with European and national automotive standards;
- high-quality [technical support](#) and [documentation](#).

* DUT-E AF/232/485.

** DUT-E A5/A10/F/I.

*** DUT-E AF/232.

See figure 1 for identification codes for [DUT-E](#) ordering.

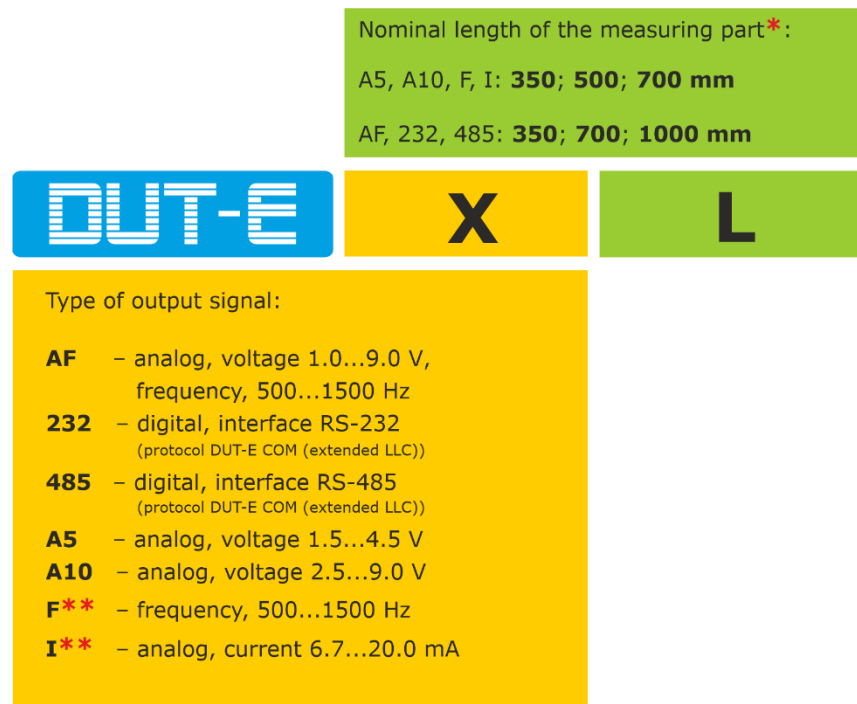

* Per special order sensor can be manufactured with any custom measuring probe length up to 1400 mm. For orders less than 200 pieces in calendar quarter, 20 % extra fee is applied.

** Manufacture upon special order is possible.

Figure 1 –DUT-E order identification codes

Examples of DUT-E ordering identification codes:

Fuel level sensor DUT-E A10 L=700 mm, (output voltage from 2.5 to 9.0 V, nominal measuring probe length 700 mm).

Fuel level sensor DUT-E 232 L=1000 mm, (RS-232 interface, nominal measuring probe length 1000 mm).

For DUT-E AF/232/485 configuration a service adapter [SK DUT-E](#) is used, which is ordered additionally, and Service DUT-E software at <https://www.jv-technoton.com/>, in [Software/Firmware](#) category.



ATTENTION: It is strongly recommended to follow strictly the instructions of the present Manual when using, mounting or maintaining DUT-E.

[The Manufacturer](#) guarantees DUT-E compliance with the requirements of technical regulations subject to the conditions of storage, transportation and operation set out in this Manual.



ATTENTION: Manufacturer reserves the right to modify DUT-E specifications that do not lead to a deterioration of the consumer qualities without prior customer notice.

1 General information and technical specifications

1.1 Purpose of use and application area

DUT-E are designed for accurate measurement of liquid fuel and other non-conductive fluids levels in fuel tanks of vehicles and tractors, as well as in fixed tanks (see figure 2).

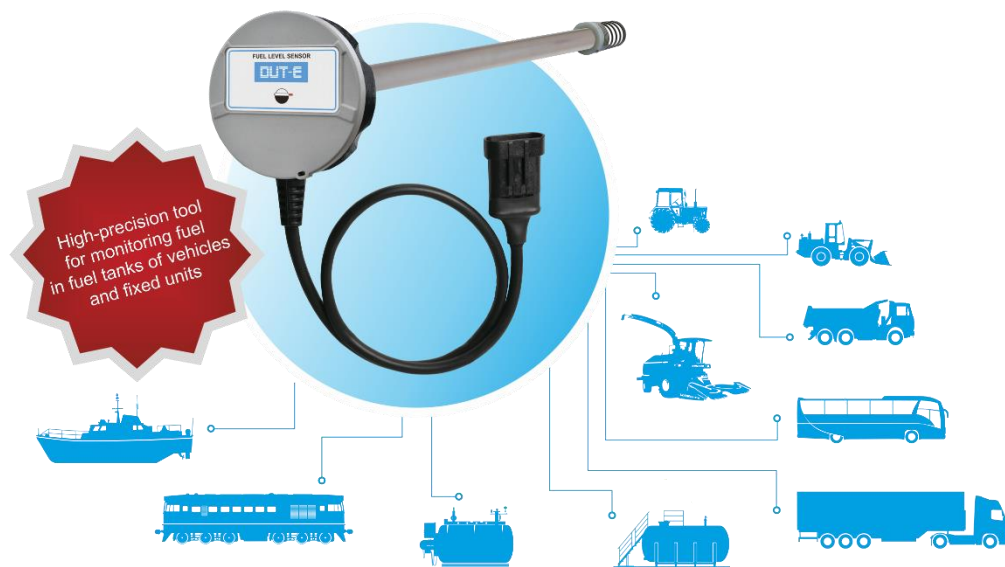

Figure 2 – DUT-E purpose of use

Application areas:

DUT-E sensors are employed within [Telematics systems](#) for monitoring trucks, buses, railway and water transport, fixed fuel tanks, diesel generators, boilers and burners (see figure 3).

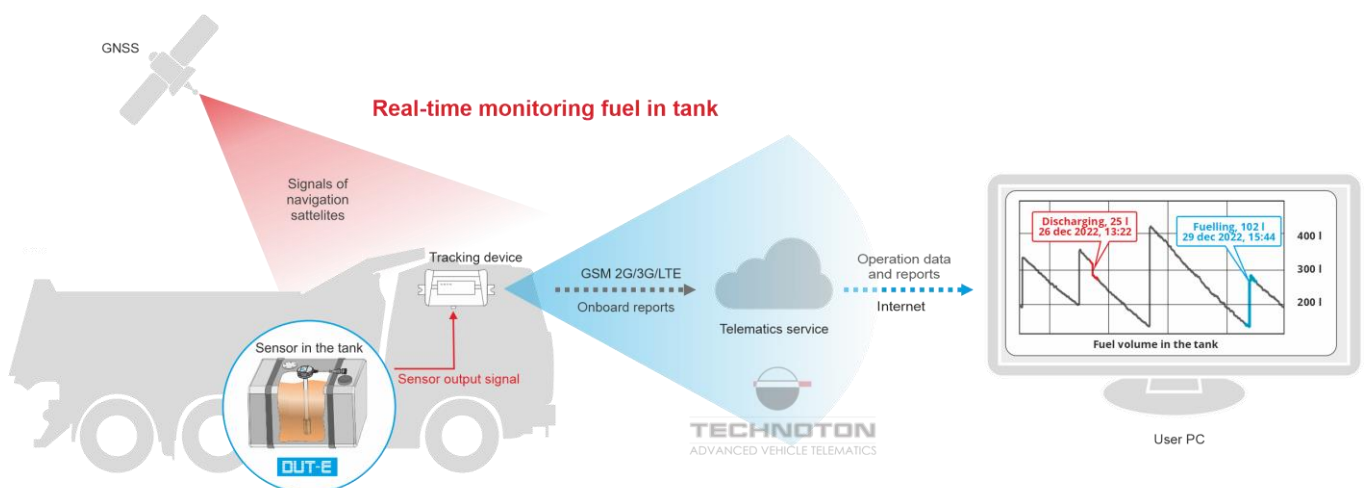

Figure 3 – Example of DUT-E operation as part of the Telematic system

[DUT-E](#) is mounted in the fuel tank of a vehicle or in a fixed tank. The sensor measures fuel level in the tank and transfers the output signal to the respective input of the [Telematics terminal](#).

The Terminal collects, records and stores the received data and transfers them to the [Telematics server](#). Server software processes and analyzes the received data to generate [Analytical reports](#) for a selected period of time (see figure 4).

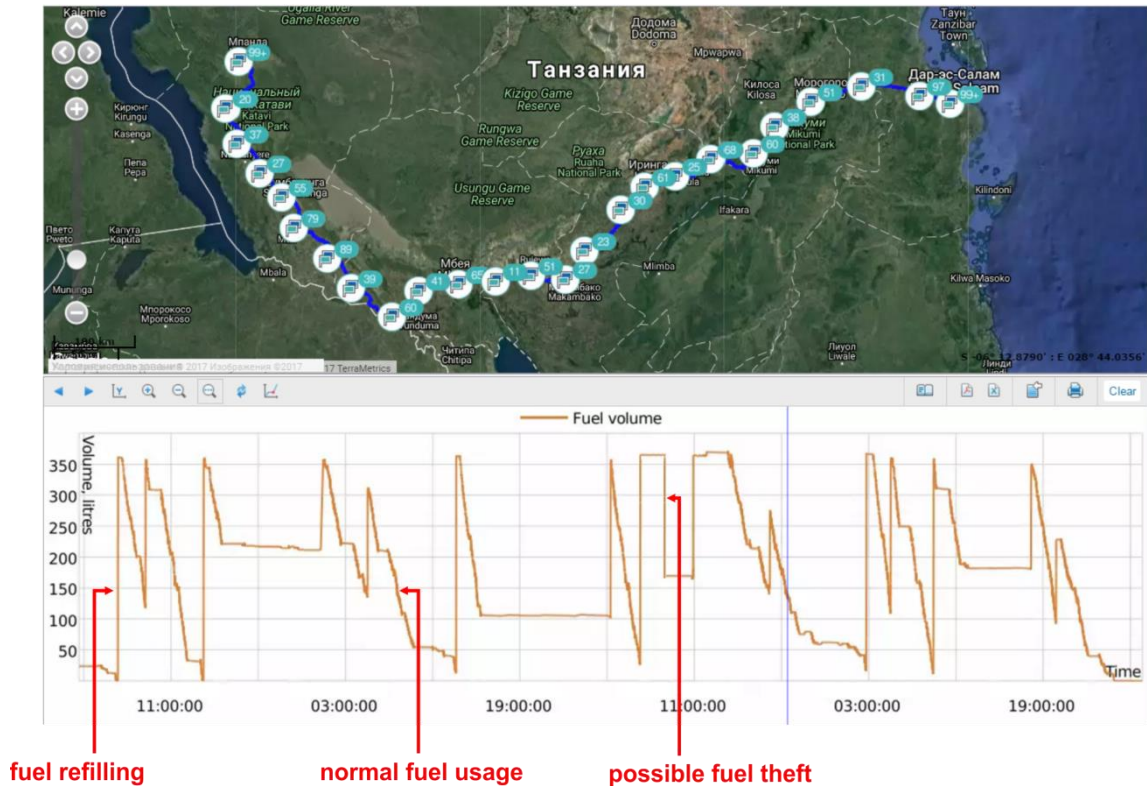

Figure 4 — Example of a Report on changing the volume of fuel in the tank, based on data received from DUT-E



RECOMMENDATION: [ORF 4](#) / [ORF 5](#) vehicle monitoring web-server provides the best accuracy of reports on movement tracking and fuel consumption monitoring. Reports contain detailed data required for effective monitoring of vehicles and drivers' operation: operation time, time and location of parking, fuel consumption, refueling and fuel drains/thefts, movement route, speed and other parameters.

DUT-E application as a part of vehicle [Telematics system](#) allows operator to:

- receive accurate information on the current amount of fuel in the tank;
- determine exact refueling amount;
- reveal fuel theft facts;
- monitor fuel consumption rate.

1.2 Exterior view and delivery set

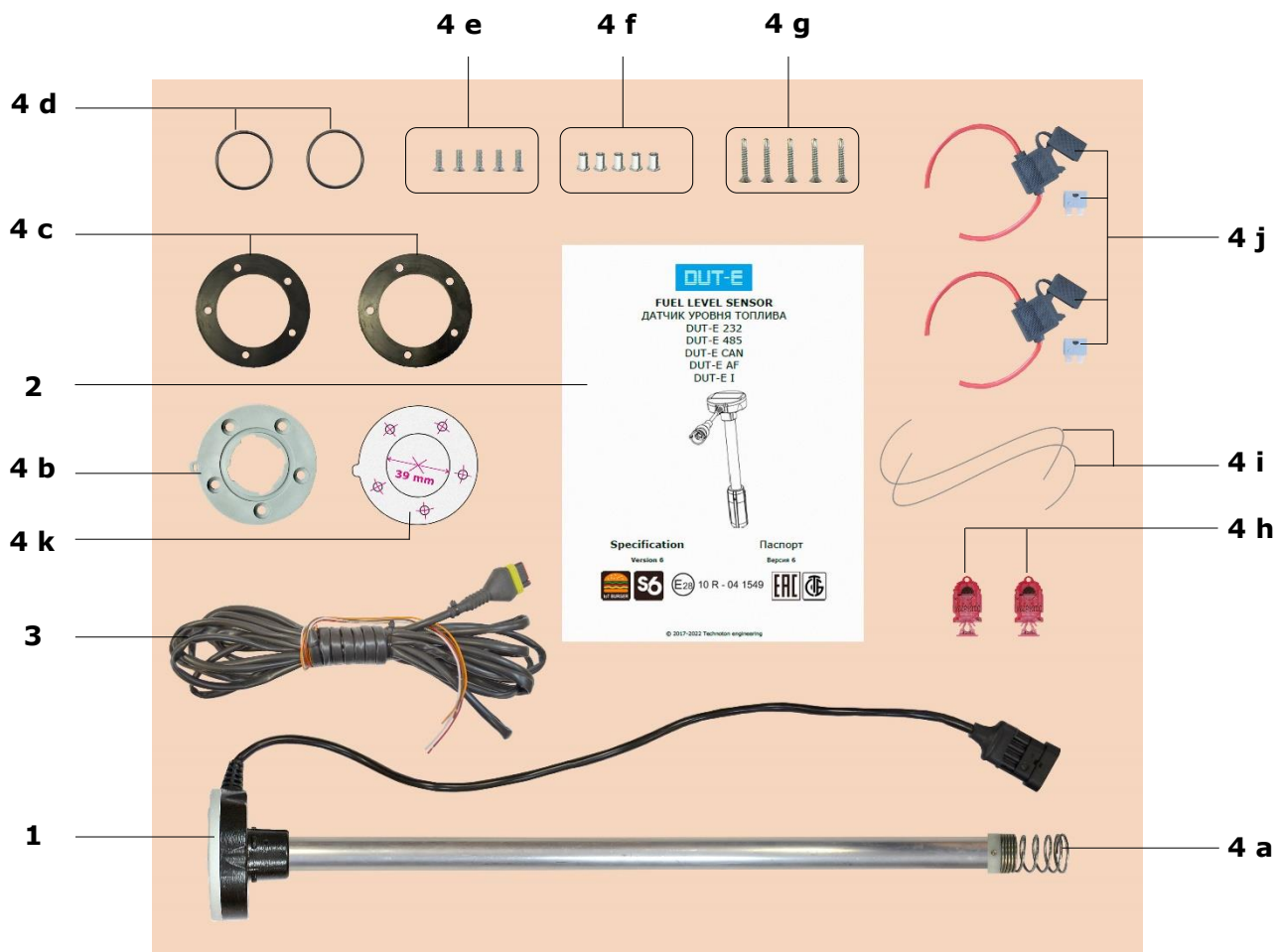

- | | | |
|-----------|---|-------------|
| 1 | - DUT-E fuel level sensor | - 1 pc.; |
| 2 | - Specification with factory settings sheet | - 1 pc.; |
| 3 | - signal cable (7.5 m) | - 1 pc.; |
| 4 | - Mounting kit (1 pc.) including: | |
| a) | bottom stop | - 1 pc.; |
| b) | plastic mounting plate | - 1 pc.; |
| c) | rubber gasket | - 2 pcs.*; |
| d) | sealing rubber ring | - 2 pcs.*; |
| e) | bolt | - 5 pcs.; |
| f) | threaded rivet | - 5 pcs.; |
| g) | self-tapping screw | - 5 pcs.; |
| h) | plastic seal | - 2 pcs.**; |
| i) | sealing cord | - 2 pcs.; |
| j) | fuse with holder (2 A) | - 2 pcs.; |
| k) | hole placement template | - 1 pc. |

Figure 5— DUT-E delivery set

* 1 pc. is for initial DUT-E GSM mounting and 1 pc. as a spare part.
The delivery set may include just 1 gasket of 4 mm.

** Exterior of seal can be different.

1.3 Design and operation principle

DUT-E fuel level sensor (see figure 6) consists of a measuring probe **(1)**, fuel level sensor "head" with an electronic module located inside **(2)**, interface cable **(3)** with connector for electrical connection **(4)**.

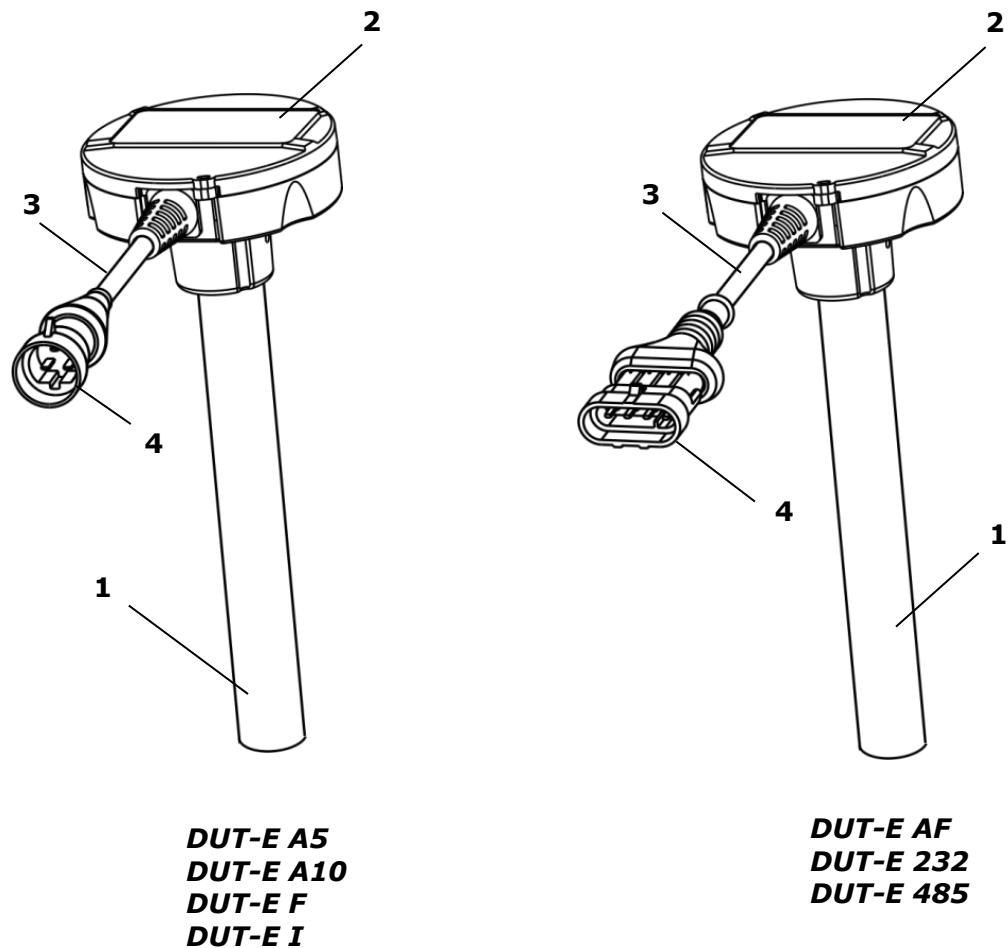

Figure 6 — DUT-E structure

DUT-E operation principle is based on condenser capacitance measurement, where measuring probe pipes are used as capacitor plates. Electric capacitance changes depending on measuring probe immersion depth in the fuel which is dielectric liquid. The sensor analyzes current value of electric capacitance and then generates an appropriate output signal.



WARNING: Capacitive principle ensures highest accuracy of liquid measurement when the liquid has **constant dielectric permeability coefficient**. Otherwise, additional inaccuracy of measurement may appear.

Fuel level translation is carried out in accordance with [calibration table](#). To create the table, it is necessary to calibrate the fuel tank. This procedure is a sequence of fixed refueling portions from empty to full tank. During calibration, the value of DUT-E output signal is established depending on fuel amount in a particular tank (see [DUT-E fuel level sensor installation](#) video for details).

[DUT-E](#) can be used in combination with recording and display units (including GPS/GLONASS Vehicle [Tracking devices](#)), and their input signal specifications have to be compatible with DUT-E output signal specification according to clauses [1.4.2](#), [1.4.3](#), [1.4.4](#).



ATTENTION: The output signal type is indicated on the label of its interface cable.

When using DUT-E AF/A5/A10/F/I sensors, the fuel volume is calculated in the Tracking device (e.g. in the Terminal) or in a commercial server by the software of the transport monitoring system.

DUT-E 232/485 sensors can by themselves calculate the current fuel volume in the tank, in accordance with the calibration table, which is entered into the sensor internal memory with the help of [Service DUT-E](#) service software.

To enhance measurements accuracy, DUT-E AF/232/485 have features of automatic output signal correction which are configured with the help of service software, such as: — filtering by time, thermal correction (see [3.10.5](#)) and thermal compensation features (see figure 7).

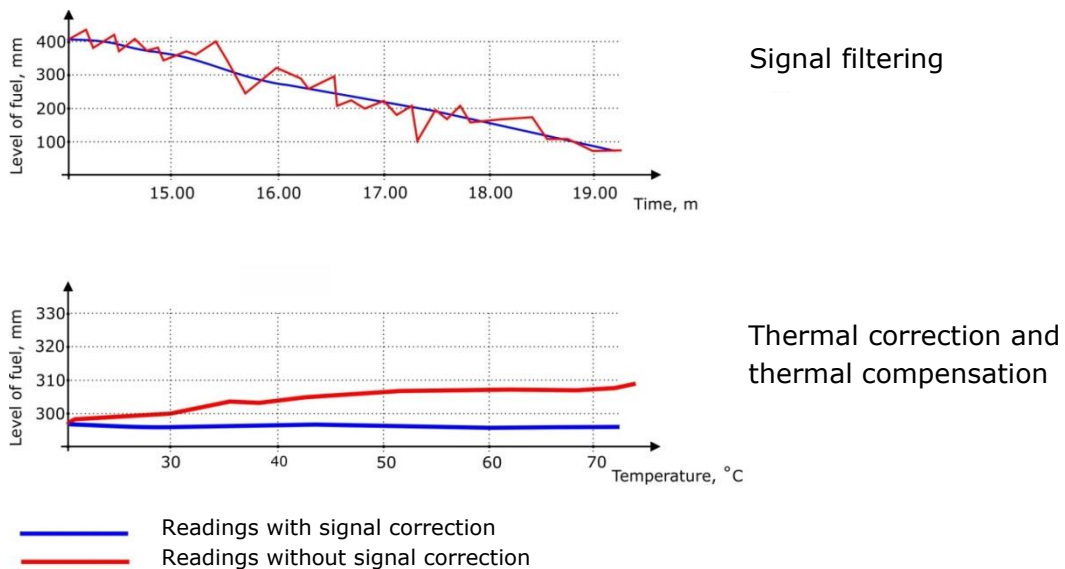

Figure 7 — Activated features of DUT-E AF/232/485 output signal automatic correction

1.4 Technical specifications

[DUT-E](#) is powered by on-board power supply of the [Vehicle](#) where it is installed.

DUT-E can be used in the conditions of temperate and cold climates.

For resistance to mechanical impact DUT-E is shake and shockproof.

1.4.1 Main specifications

Table 1 — DUT-E main specifications

Parameter, measuring unit	Value
Working fluid	Diesel fuel*
Fuel level sensor operating principle	Capacitive
Relative measuring error (to the length of the measuring part), %, not more than	±1.0
Power supply voltage range, V	10...50
Maximal current consumption at supply voltage 12/24 V, mA, not more than	50/25
Availability time after power-up, seconds, not more than	10
Maximum trimming of the measuring probe	see 2.2.3
Maximum length increase, mm, not more than	see 2.2.4
Temperature range, °C	-40...+85
Ingress protection rating	IP55/IP57
Resistance to external vertical mechanical pressure on the cap of the sensor "head", kg, no more than	1500
Electromagnetic compatibility	see annex E
Weight, kg, not more than	0.6 (at L=1000 mm) 0.5 (at L=700 mm) 0.4 (at L=350 mm)
Overall dimensions, mm, not more than	see figure 8
<p>* The sensor is allowed to operate using other types of fuel. However, it should be taken into consideration that while using the sensor in the explosive environment, the sensor must be electrically connected through the external power and spark protection unit (purchased separately), to meet the requirements regarding the spark-proof electric circuit. The spark-proof circuit must meet the following parameters:</p> <ul style="list-style-type: none"> - maximum input voltage — 10 V; - maximum input current — 200 mA; - maximum internal capacity — 15.0 µF; - maximum inherent inductance — 1.188 mHn. 	

1.4.2 Specifications of DUT-E AF output signal

[DUT-E AF](#) sensor has an analog or frequency output which is configured via K-Line (ISO 14230) service interface using Service DUT-E software.

Output signal of DUT-E AF linearly depends on measured level of fuel in tank and is independent from supply voltage.

Resolution of digital-analog conversion of output signal is 12 bits.

Depending on configuration, DUT-E AF sensor's output signal value can represent:

- fuel level in the tank (mm);
- fuel volume (L);
- total fuel volume (L) of up to eight tanks.

The output signal of DUT-E AF corresponding to the fuel volume is generated in accordance with the calibration table recorded into the sensor internal memory.

Summation of up to 8 pcs. of DUT-E AF sensors is allowed, in case of their joint operation together with [DUT-E SUM AF](#) summatoms (purchased separately).

Table 2 — Specifications of DUT-E AF output signal

Parameter, measuring unit	Value*	
	voltage output	frequency output
Adjustable range of voltage change, V	1.0...9.0**	-
Range of frequency change, Hz	-	500...1500
Frequency signal form	-	Meander
Duty cycle, %	-	50
Low level voltage, V, not higher than	-	0.5
High level voltage, V	-	10.0±1.0
Output resistance of high level, kOhm, not higher than	-	5
Output resistance of low level, kOhm, not higher than	-	50
Input resistance of connected device, kOhm, not higher than	10	-
* The values are applicable for sensor with standard measuring length. In case of changing probe length (cutting/extending) sensor calibration should be carried out.		
** Sensor output signal voltage range may be specified both in direct and inverse relation.		

1.4.3 Specifications of DUT-E A5/A10/F/I output signal

Output signal voltage values (for [DUT-E A5](#) and DUT-E A10), frequency values (for DUT-E F) and current values (for DUT-E I) are linear dependent on fuel level in the tank.

Output signal value does not depend on supply voltage value.

- Input resistance of the device DUT-E A5/A10 is connected to should not be less than 10 kOhm.
- Output stage of DUT-E F – open collector with load resistor of 10 kOhm.
- Input resistance of the device DUT-E I is connected to should not be more than 260 Ohm for 12 V power supply voltage and should not be more than 800 Ohm for 24 V power supply voltage.

For DUT-E I correct performance the difference between minimum on-board power supply voltage and load voltage for the full tank should not be less than 5 V.

Table 3 — DUT-E A5/A10/F/I output signal specifications

DUT-E model	Fuel tank status	Voltage, V		Frequency, Hz		Current, mA	
		for nominal probe length	for 30 % cut probe	for nominal probe length	for 30 % cut probe	for nominal probe length	for 30 % cut probe
DUT-E A5	Empty	1.5	0.9	-	-	-	-
	Full	4.5	3.7	-	-	-	-
DUT-E A10	Empty	2.5	1.0	-	-	-	-
	Full	9.0	5.6	-	-	-	-
DUT-E F	Empty	-	-	500	262	-	-
	Full	-	-	1500	941	-	-
DUT-E I	Empty	-	-	-	-	6.7	4.0
	Full	-	-	-	-	20.0	16.4

1.4.4 Specifications of DUT-E 232/485 output signal

Specifications of [DUT-E 232](#) and DUT-E 485 output signal correspond to the specifications of RS-232 and RS-485 interfaces.

Depending on settings output value of DUT-E 232 and DUT-E 485 can stand for:

- standard (normalized) units, from 0 to 1000 (0 – empty tank, 1000 – full tank);
- fuel level in the tank (mm);
- fuel volume (l);
- percentage of full tank capacity (%).

DUT-E sensor sends data on current temperature as well (value is measured with the temperature sensor located on the PCB).

Summation of up to 8 pcs. of DUT-E 232 sensors is allowed, in case of their joint operation together with [DUT-E SUM 232](#) summators (purchased separately).

In case the nominal value is changed, the sensor calibration is obligatory.

Data transfer of DUT-E 232/485 is conducted in accordance with [DUT-E COM Protocol](#) (extended LLS), in the "request/response" mode and in the automatic mode of data transfer (ASCII/ASCII EXT/HEX).

Examples of the sensor settings for data transfer according to ASCII text protocol with examples of data display are provided in [annex F](#).

1.4.5 Compatibility with Terminals and receiving devices

[DUT-E](#) sensors may be used together with [Telematics terminals](#) or other tracking devices whose input specifications correspond to parameters of output signals, in accordance with [1.4.2](#), [1.4.3](#), [1.4.4](#).

[Technoton](#) regularly conducts compatibility and mutual accuracy tests of all manufactured products with Terminals of different models.

A [table](#) containing the up-to-date list of Declarations of compatibility of Telematics terminals from different manufacturers with products manufactured by Technoton is provided at: <https://www.jv-technoton.com/>.

Recommendations on the equipment connection and configuration can be received at the Technoton [technical support](#) service.

1.4.6 Overall dimensions

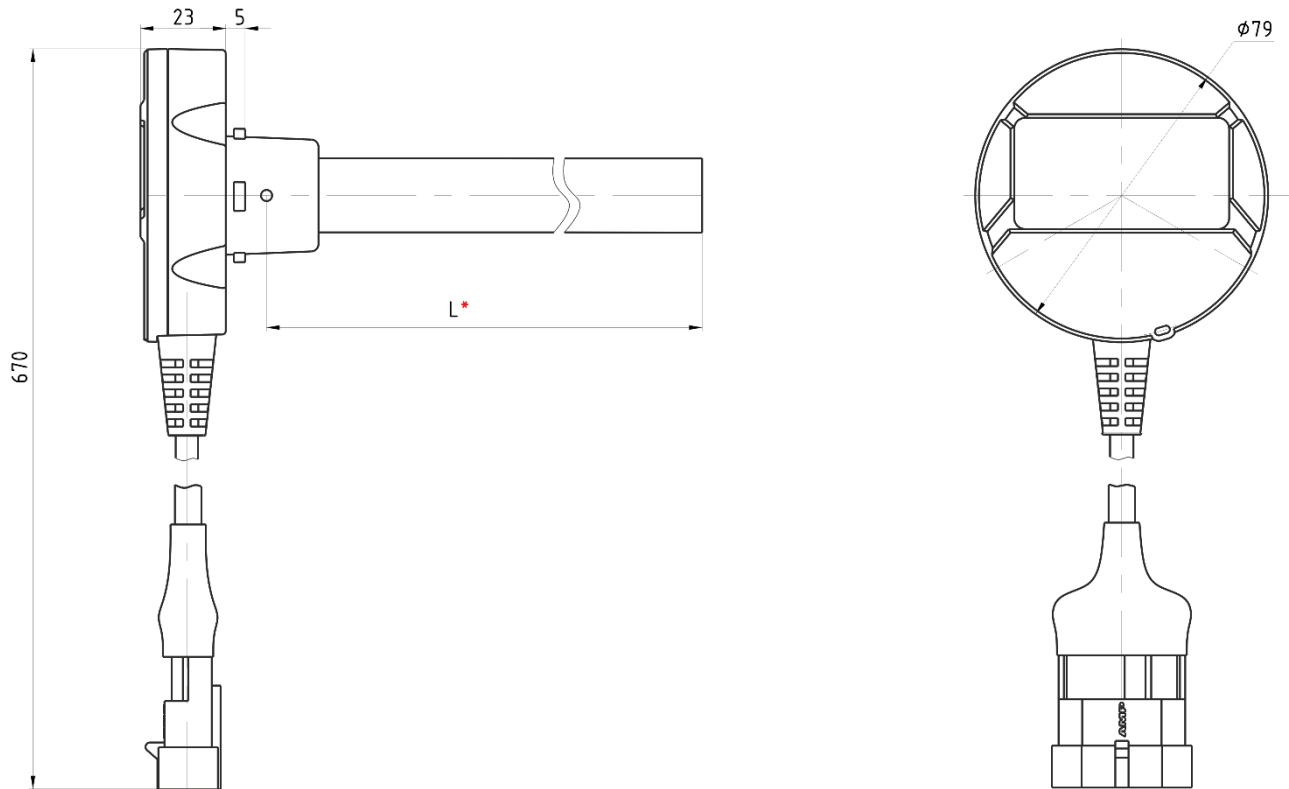

Figure 8 — *DUT-E* overall dimensions

* Nominal measuring probe length (350 mm/500 mm/700 mm/1000 mm, see [figure 1](#)).

2 DUT-E installation

For [DUT-E](#) correct operation its mounting and configuration should be carried out by certified specialists who have passed [corporate technical training](#).



ATTENTION: During sensor mounting you are to follow general health and safety rules for repairing vehicles and tractors, as well as health and safety rules established at a particular company.

In this chapter, general recommendations regarding mounting DUT-E sensor are provided. Detailed instructions regarding the sensor installation are provided in the [DUT-E/DUT-E 2Bio/DUT-E GSM/DUT-E S7 installation manual](#).

The following tools and accessories are recommended to have for DUT-E mounting:

- Small tools: (box wrench kits, drive sockets, screwdrivers, pliers, jab saw or angle grinder with a cutoff disk, rivet spinner).
- Drill (screw driving machine) with a set of drill bits for metal.
- Hollow drill set, d=38 mm.
- Verified measuring reservoir for fuel (10...20 l volume).
- If the tank volume is greater than 200 l, the fuel filling station with a counter or [DUT-E ATS automatic calibration station](#) are desirable.
- Calibration pipe with one end sealed, its length being no less than the height of the tank to be equipped.
- Silicone sealing compound.
- Rags.
- Diesel fuel; full tank for each Vehicle.
- Spare tank for fuel of volume equal to that of the given fuel tank;
- To configure DUT-E AF/232/485 models — [SK DUT-E](#) service adapter which is purchased separately and PC with [Service DUT-E](#) software installed.



RECOMMENDATION: Tank calibration using DUT-E ATS automatic calibration station eliminates the impact of human factor on the calibration accuracy and reduces the calibration error down to ± 0.5 % of the tank volume, it also reduces by 2...3 times labor costs and time for the tank calibration (see [DUT-E ATS operation manual](#)).

2.1 Exterior inspection prior to works start

It is necessary to conduct DUT-E exterior inspection for the presence of the possible defects arisen during transportation, storage or careless use.

Contact the product supplier if there any defects.

2.2 General recommendations for sensor installation

2.2.1 Standard fuel sensor replacement

DUT-E can be mounted either into the flange of factory mounted float sensor* or into a specially drilled hole of the fuel tank.



ATTENTION: If the standard fuel sensor is not located in the geometrical center of the tank, it is not recommended to replace it with [DUT-E](#). DUT-E installation far from the geometrical center of the tank will lead to significant fluctuations in fuel level readings.

Dismount the standard sensor and clean the mounting area before DUT-E mounting.

M5x16 bolts can be used for installation; they are included into the [delivery set](#). Bolt or screw heads must be completely sunk in the mounting plate (see figure 9).



Figure 9 – Mounting plate screwed to the tank

Preorder correspondent mounting plate to replace the standard sensor with **SAE 5 bolt** bores layout.



RECOMMENDATION: For a further easier sealing of sensor pass the sealing cord through the sealing hole of the plate **prior** to fastening the plate to the tank!

* Study carefully the layout of the mounting bores for a factory mounted fuel sensor and compare it with the drawing of bores for a mounting plate.

2.2.2 Installation into a special hole

IMPORTANT:



- 1) Before drilling a bore in a fuel tank, the tank must be emptied, dismantled (if necessary) and dried or filled with water.
- 2) Before drilling, make sure that there are no bulkheads that interfere [DUT-E](#) installation.
- 3) Eliminate contact of DUT-E measuring probe with the bar of the standard float fuel sensor.

Sequence of operations during mounting DUT-E:

- 1) Determine installation location. **Geometrical center of the fuel tank** is recommended (see figure 10). This will reduce measurement errors caused by fuel level deviation during driving.

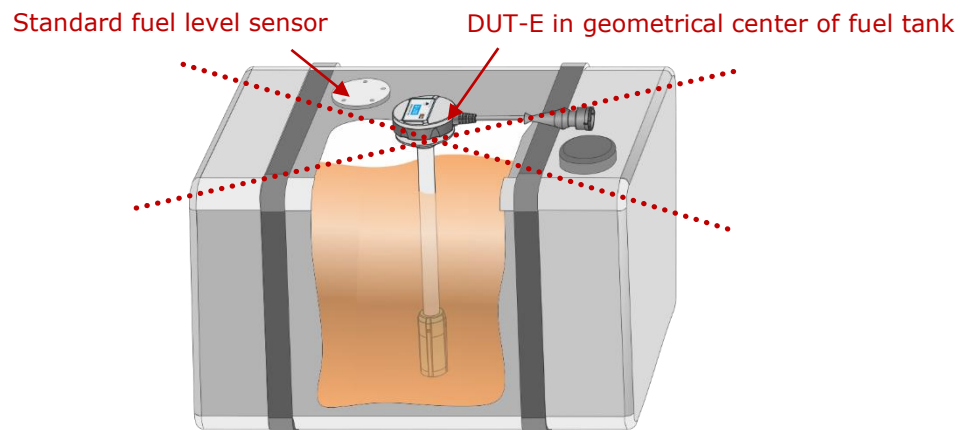

Figure 10 — Recommended location for a DUT-E installation

- 2) Stick hole placement template from DUT-E [delivery set](#) to the top of the tank and drill holes accordingly (see figure 11).

We recommend to drill a hole for the sensor mounting plate with a hollow drill set **38 mm** in diameter.



BE CAREFUL: The mounting plate can be installed only in one position on the bores prepared! Before marking and drilling, examine the place where you plan to fix the mounting plate because sealing holes should be accessible.

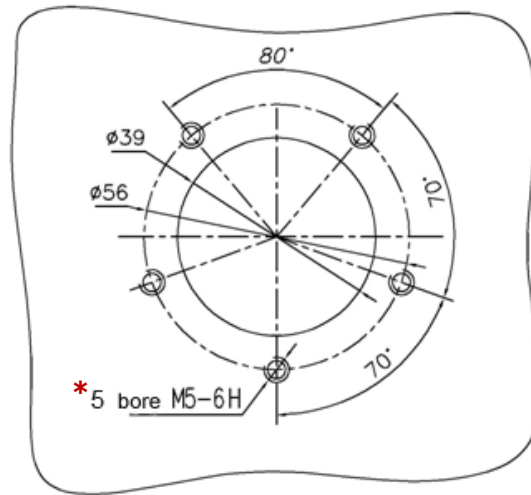

* While installing fastening plate with threaded rivets, make $d=7\text{ mm}$ holes for rivets.

Figure 11 — Bores layout for sensor mounting plate fastening

3) Put rubber gasket and fastening plate over prepared holes, fix them with screws and threaded rivets of with self-tapping screws from [MK DUT-E](#) mounting kit (see figure 12).

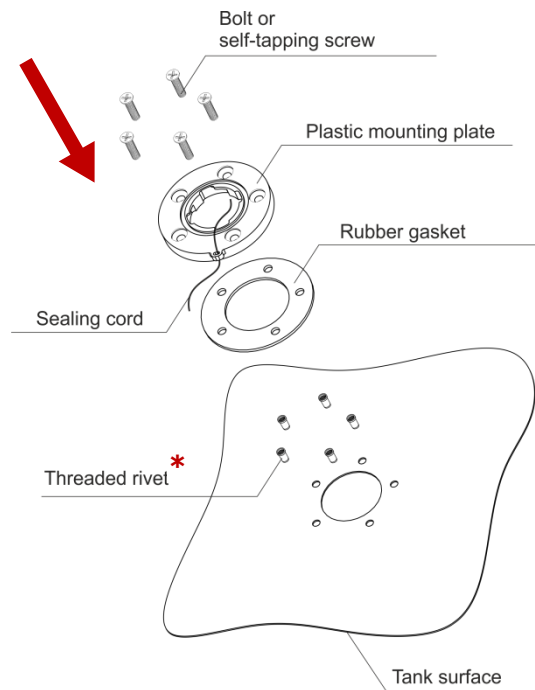

* Recommend for installation of sensor in fuel tank with thin walls (**less than 2 mm**).

Figure 12 — Mounting plate fastening

When using threaded rivets, they should be mounted using riveter and according to figure 13.

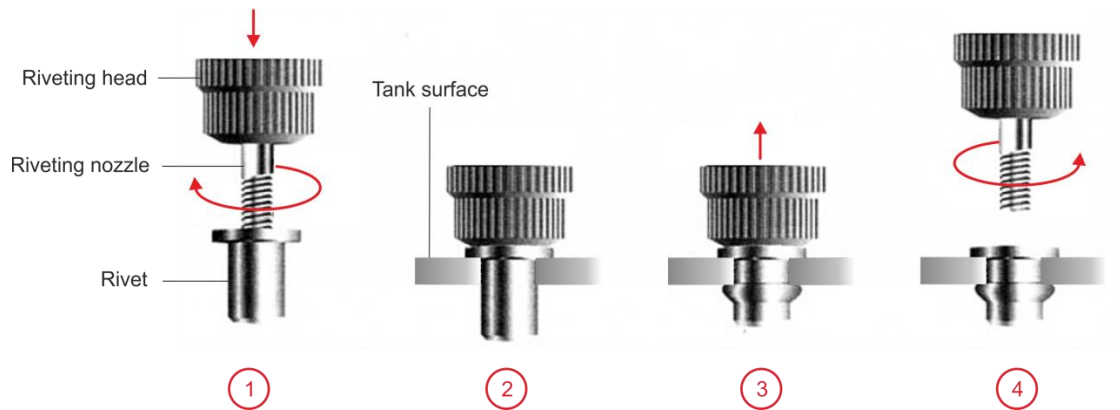

a) threaded rivets procedure of installation



b) installed fastening plate view of from inside of tank

Figure 13 — Threaded rivets usage for sensor installation



ATTENTION: When fixing the mounting plate to the tank, make sure that the bolt or screw heads are not skewed and completely sunk in the plate in order to provide **electrical isolation** between the tank and [DUT-E](#).

2.2.3 Probe cutting according to tank depth



ATTENTION: DUT-E AF/232/485 allow cut off up to any required probe length with mandatory further calibration.

DUT-E A5/A10/F/I allow cut off up to 30 % of the initial length of the measuring probe with no further calibration.

Sequence of operations during cutting the measuring probe of [DUT-E](#):

1) Measure the depth of the tank from mounting plate to the bottom.



IMPORTANT: It is required to leave a 20...30 mm gap between the edge of the measuring probe and the tank bottom to:

- provide at least 10 mm operation area for bottom spring stopper (if the bottom spring is fixed in full loading position the bayonet mounting plate can get damaged);
- avoid the short circuit of the measuring probe tubes with conductive mud or water at the tank bottom.

2) Cut off DUT-E probe so that the edge of the probe is in 25 mm above the bottom of the tank.



Figure 14 — DUT-E measuring probe cutting and flushing the cut with fuel



RECOMMENDATION: Cut DUT-E probe with a metal hacksaw. Carefully clean the edge and wash the tubes with clean fuel (see figure 14).

3) After cutting DUT-E AF/232/485, the sensor calibration is obligatory (see [3.10.3](#)).

2.2.4 Length extension

Length extension option significantly decreases expenses on storage and transportation. The sensor length is extended by means of attachment of [additional sections of DUT-E](#) to its measuring probe (see figure 15 and [DUT-E Length extension with KDC](#) video).

DUT-E AF/232/485 can be extended up to 6000 mm length.

DUT-E A5/A10/F/I extension is possible only up to the initial size of particular sensor (if been cut).

Model range of additional sections includes: **KDC 250**, **KDC 500** and **KDC 1000** (lengths of 250, 500 and 1000 mm respectively).

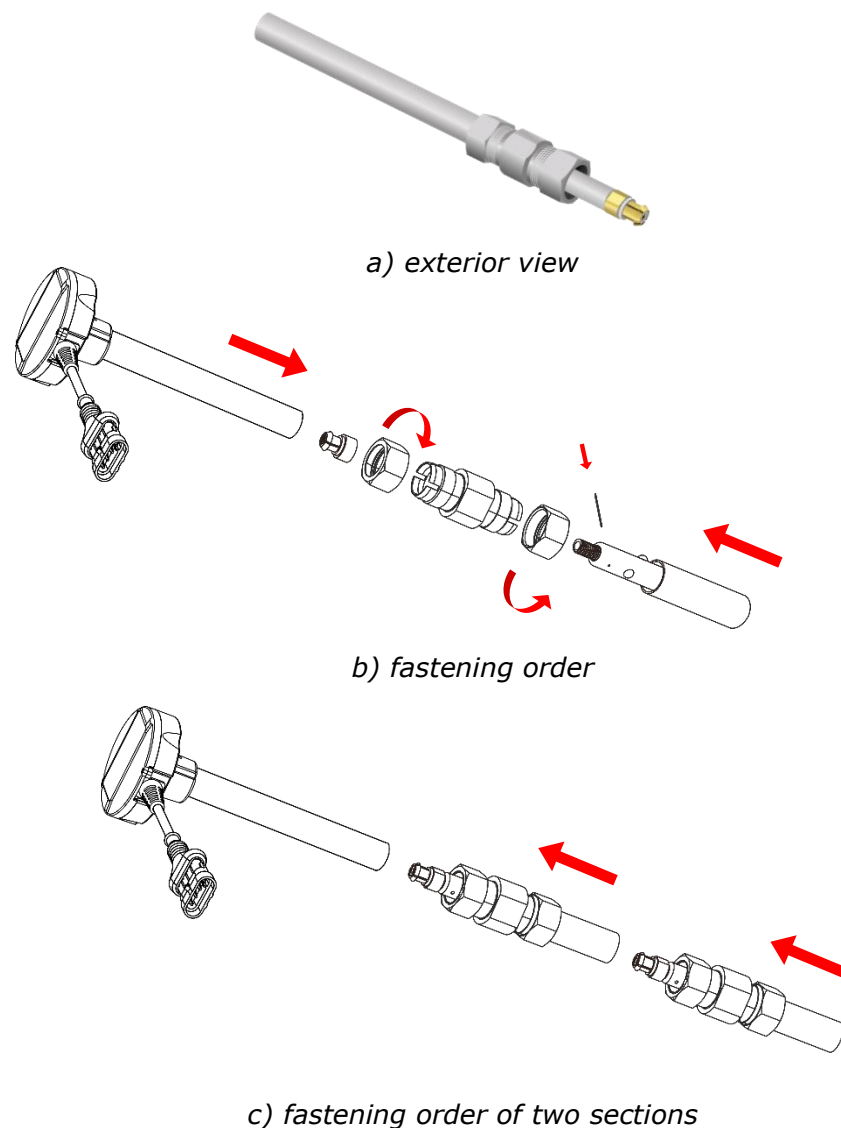

Figure 15 — Additional section DUT-E

In case you fix additional sections, the force moment of tightening the threaded connection of the internal tube must be **10 N/m**, and that of the external tube must be **40 N/m**.

Additional sections can be cut to necessary size. Follow instructions of clause [2.2.3](#) when cutting the sections.

After length extension DUT-E AF/232/485, the sensor calibration is obligatory (see [3.10.3](#)).

2.2.5 Mounting a screen filter and fixing the sensor

Before fixing [DUT-E](#), put the **screen filter** (purchased separately) at the end of the sensor measuring probe (see figure 16 a); it serves to protect the measuring probe electrodes from water and dirt. Using the screen filter allows to increase considerably the sensor non-failure service life (see the video [Screen filter of a fuel level sensor](#)).

The screen filter is fixed in accordance with sequence of operations shown in figure 16 b. First, a fixing element is put on the measuring probe. Then, the bottom stop is mounted and fixed with two screws on the side. The screen filter is put over the bottom stop and fixed with locks of the fixing element.

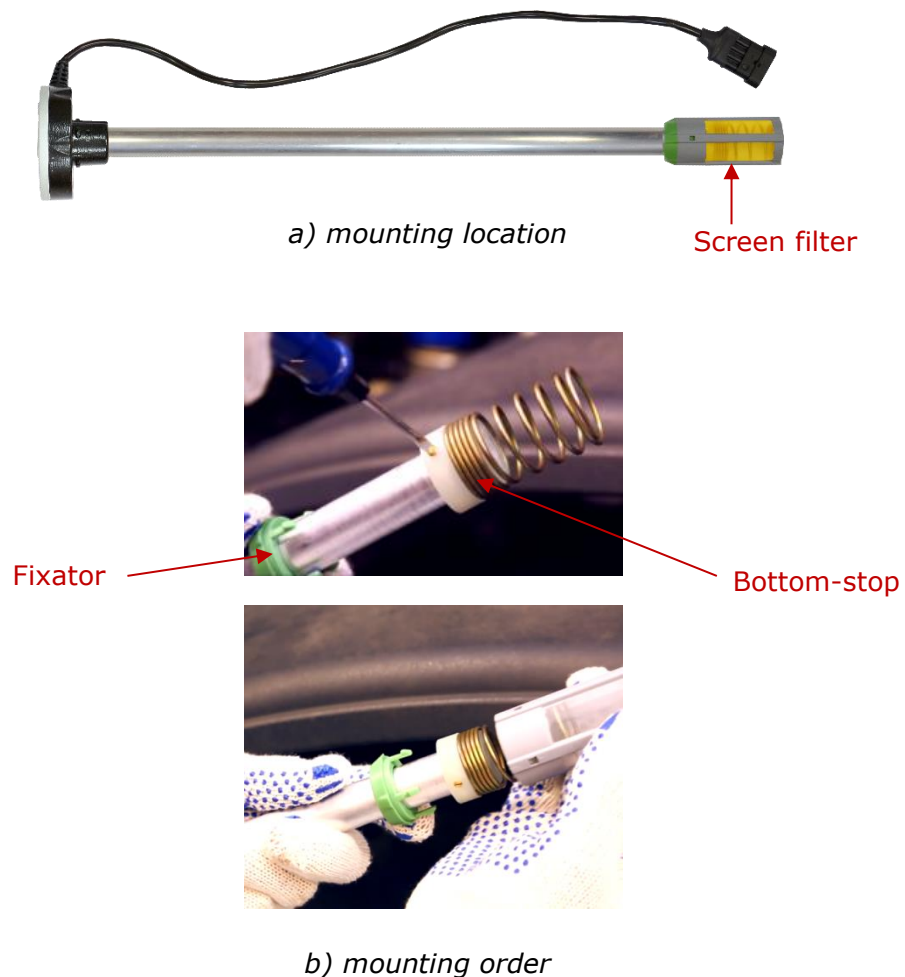

Figure 16 – Mounting a screen filter



ATTENTION: Screen filter cannot be used without installed bottom spring stop.

To fix **DUT-E** place the sealing ring into the groove of the mounting plate and put the sensor measuring probe, with the screen filter mounted, down into the hole. Then, press the sensor "head" and fix it by turning it clockwise (see figure 17).



RECOMMENDATION: It is recommended to put some oil or fuel on the sealing ring of the mounting plate to prevent its deformation during DUT-E mounting.

The mounting should be carried out so that both sensor and mounting plate sealing holes would match one another after locking the DUT-E.

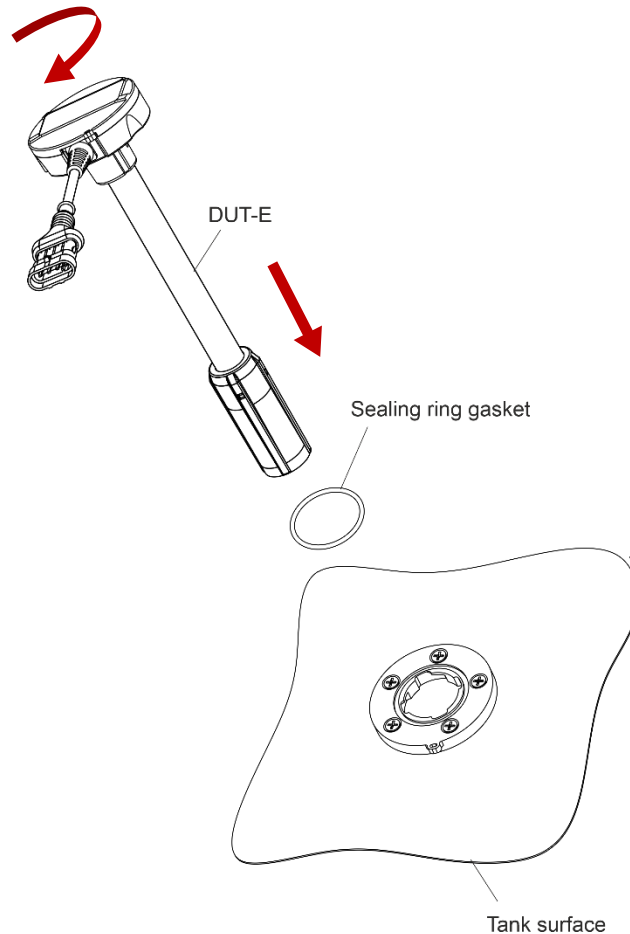

Figure 17 – DUT-E mounting order

2.3 Electrical connection



ATTENTION:

- 1) To ensure proper operation of [DUT-E](#), it should be electrically connected by specialist, who finished [official technical training](#) and was certified for that.
- 2) During DUT-E electrical connection, you are to follow strictly health and safety rules for conducting repair operations, as well as health and safety requirements established at the company.

[DUT-E](#) is powered from the Vehicle onboard circuit. For electrical connection, use the **signal cable** from the [delivery set](#).



IMPORTANT:

- 1) Before mounting and connecting DUT-E switch off power supply of the vehicle electrical circuits. To do this switch off the battery switch or release the terminals of the wires connected to the battery.
- 2) Prior to electrical connection of the sensor pay special attention to checking [Vehicle](#) chassis ground. Resistance between any point of vehicle chassis and "-" terminal of the battery or between terminals of the chassis ground switch should not exceed 1 Ohm.
- 3) The wires "+" (power) and "-" (ground) must be connected in the same points of Vehicle onboard circuit where corresponding wires of the Telematics terminal (tracking device) are connected.
- 4) When connecting DUT-E to onboard electrical network of Vehicle, use **fuses** from delivery set in accordance to scheme of connection (see figure 18 a). Nominal fuse current is not more than 2 A.
- 5) It is **strongly recommended** to lay signal cable together with standard electrical vehicle wiring with mandatory cable ties fixing of every 50 cm, at a positive ambient temperature (see figure 18 b).
- 6) **Quick splice connectors** (ordered separately) are recommended for electrical connection of power supply wires (see figure 18 c).

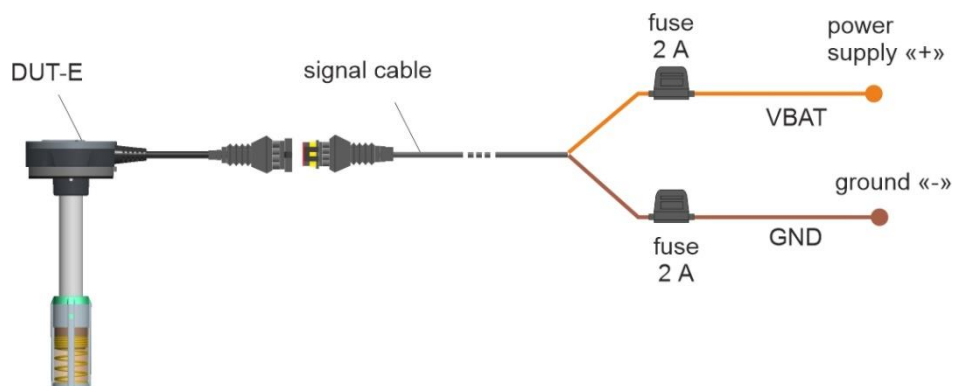

a) DUT-E to onboard electrical network scheme of connection

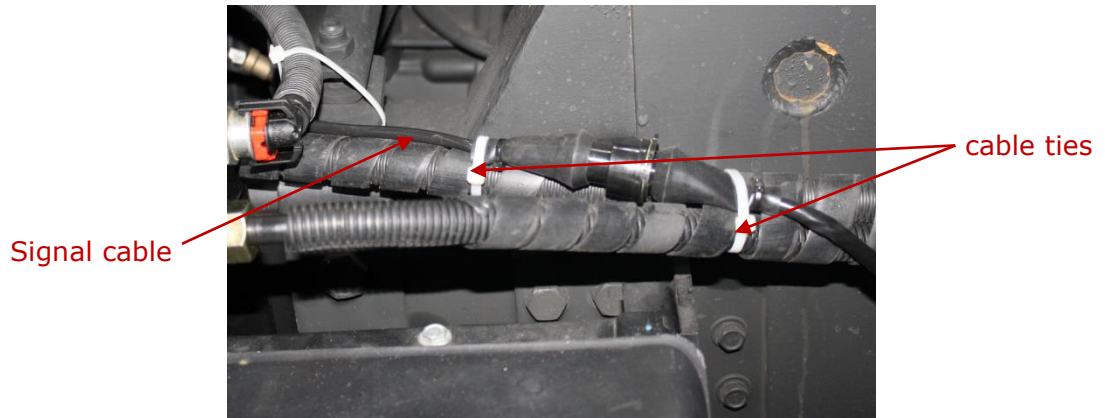

b) connection cable laying

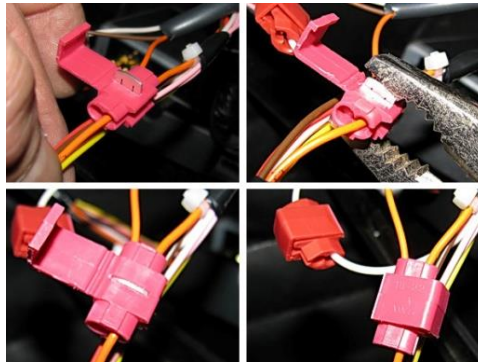

c) using connectors to connect wires of signal cable

Figure 18 – Electrical connection of DUT-E



IMPORTANT: [DUT-E](#) body is electrically connected to Ground “-” (brown wire of the connection cable). Electrical isolation between the DUT-E body and the fuel tank is provided by the mounting plate made of dielectric plastic material.

2.3.1 Electrical connection of DUT-E AF

DUT-E AF is electrically connected using the signal cable from the sensor delivery set, in accordance with the connector pinout and designation of interface cable wires, according to figure 19 and table 4.

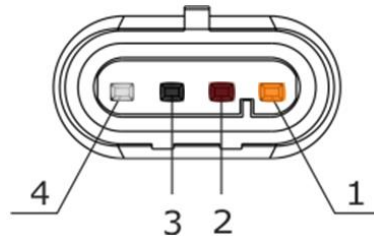





Figure 19 — Contacts of DUT-E AF interface cable connector

Table 4 — DUT-E AF interface cable wires assignment

Pin number	Wire marking	Wire color*	Assignment
1	VBAT	Orange 	Power supply "+"
2	GND	Brown 	Ground "-"
3	KLIN	Black 	Service interface, K-Line (ISO 14230)
4	T034	White 	Output signal (analog/frequency, see 1.4.2)

* [Manufacturer](#) reserves the right to modify wire colors, that is why pay attention to its marking.

2.3.2 Electrical connection of DUT-E 232/485

DUT-E 232 / DUT-E 485 is electrically connected using the signal cable from the sensor delivery set, in accordance with the connector pinout and designation of interface cable wires, according to figure 20 and table 5.

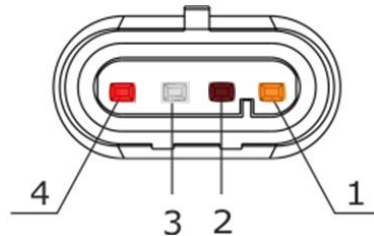





Figure 20 — Contacts of DUT-E 232 / DUT-E 485 interface cable connector

Table 5 — DUT-E 232 / DUT-E 485 interface cable wires assignment

Pin number	Wire marking	Wire color*		Assignment
1	VBAT	Orange		Power supply "+"
2	GND	Brown		Ground "-"
3	232R/485A	White		Received data (RS-232) Data exchange (RS-485)
4	232T/485B	Red		Transmitted data (RS-232) Data exchange (RS-485)

* [Manufacturer](#) reserves the right to modify wire colors, that is why pay attention to its marking.

2.7.3 Electrical connection of DUT-E A5/A10/F/I

DUT-E A5/ DUT-E A10 / DUT-E F/ DUT-E I is electrically connected using the signal cable from the sensor delivery set, in accordance with the connector pinout and designation of interface cable wires, according to figure 21 and table 6.

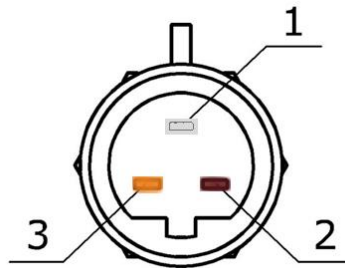





Figure 21 — Contacts of DUT-E A5/ DUT-E A10 / DUT-E F/ DUT-E I interface cable connector

Table 6 — DUT-E A5/ DUT-E A10 / DUT-E F/ DUT-E I interface cable wires assignment

Pin number	Wire marking	Wire color*	Assignment
1	T701/T034	White 	Output signal (analog/frequency/current, see 1.4.3)
2	GND/T734	Brown 	Ground “-”
3	VBAT	Orange 	Power supply “+”

* [Manufacturer](#) reserves the right to modify wire colors, that is why pay attention to its marking.

2.4 Monitoring of two and more tanks

2.4.1 DUT-E 232 readings totalizing

[DUT-E SUM 232 summator](#) designed by [Technoton](#) is used together with DUT-E 232 sensors on vehicles with two and more fuel tanks for measuring total amount of fuel (see figure 22).

ATTENTION:



- 1)** DUT-E SUM 232 summator operates only with DUT-E 232 sensors with firmware version 3.0 and higher.
- 2)** Fuel tank calibration table should be recorded into the internal memory of each sensor (see [3.10.7](#)).







Figure 22 — DUT-E SUM 232 summator

DUT-E SUM 232 output message contains total fuel volume (in liters) as a sum of the values measured by sensors connected to its **IN** and **IN/OUT** inputs.

Electrical connection of summators is carried out according to the diagrams provided in figure 23 and in compliance with wire assignment provided in table 7.

Two [DUT-E 232](#) sensors are connected to the single tracking device according to figure 23 a. If there are three or more fuel tanks to be measured with DUT-E 232 sensors, cascade connection can be used according to figure 23 b. Quick splice connectors (ordered separately) are recommended for electrical connection of signal wires.

Table 7 —DUT-E SUM 232 wires assignment

Wire number	Wire marking	Wire color*		Assignment
1	VBAT	Orange		Power supply "+"
2	GND	Brown		Ground "-"
3	232R	White		Received data (RS-232)
4	232T	Red		Transmitted data (RS-232)
* Manufacturer reserves the right to change wire colors.				

To get correct values DUT-E 232 sensors should be configured with [Service DUT-E](#) software according to the following instructions:

1) For data output in **upon request** mode the following parameters must be applied for **all** the sensors:

- **Automatic transmission mode** switched **Off** (**Operation modes** module) (see [3.10.4](#));
- **Output message** selected as **Volume (L)** (**Output message** module) (see [3.10.6](#)).

2) For data output in **automatic** mode the following parameters must be applied:

- for **all** the sensors — **Output message** selected as **Volume (L)** (**Output message** module);
- sensor **N₁** — **Automatic transmission mode** selected as **HEX**, **Message Interval (s)** value is 1 (**Operation modes** module);
- sensors **N₂ ... N_(n-1)** — **Automatic transmission mode** switched **Off** (**Operation modes** module);
- sensor **N_n** (the last one) — **Automatic transmission mode** set to **HEX\ASCII\ASCII EXT**, **Message Interval (s)** set any required by the tracking device value (**Operation modes** module).

Note — for sensor **N_n** (the last one) at least 8 second message interval is recommended.

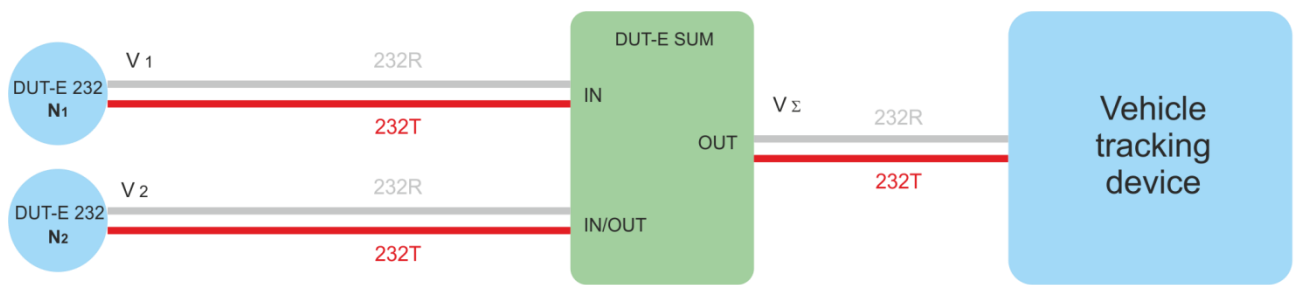

a) Connection scheme of two DUT-E 232 sensors

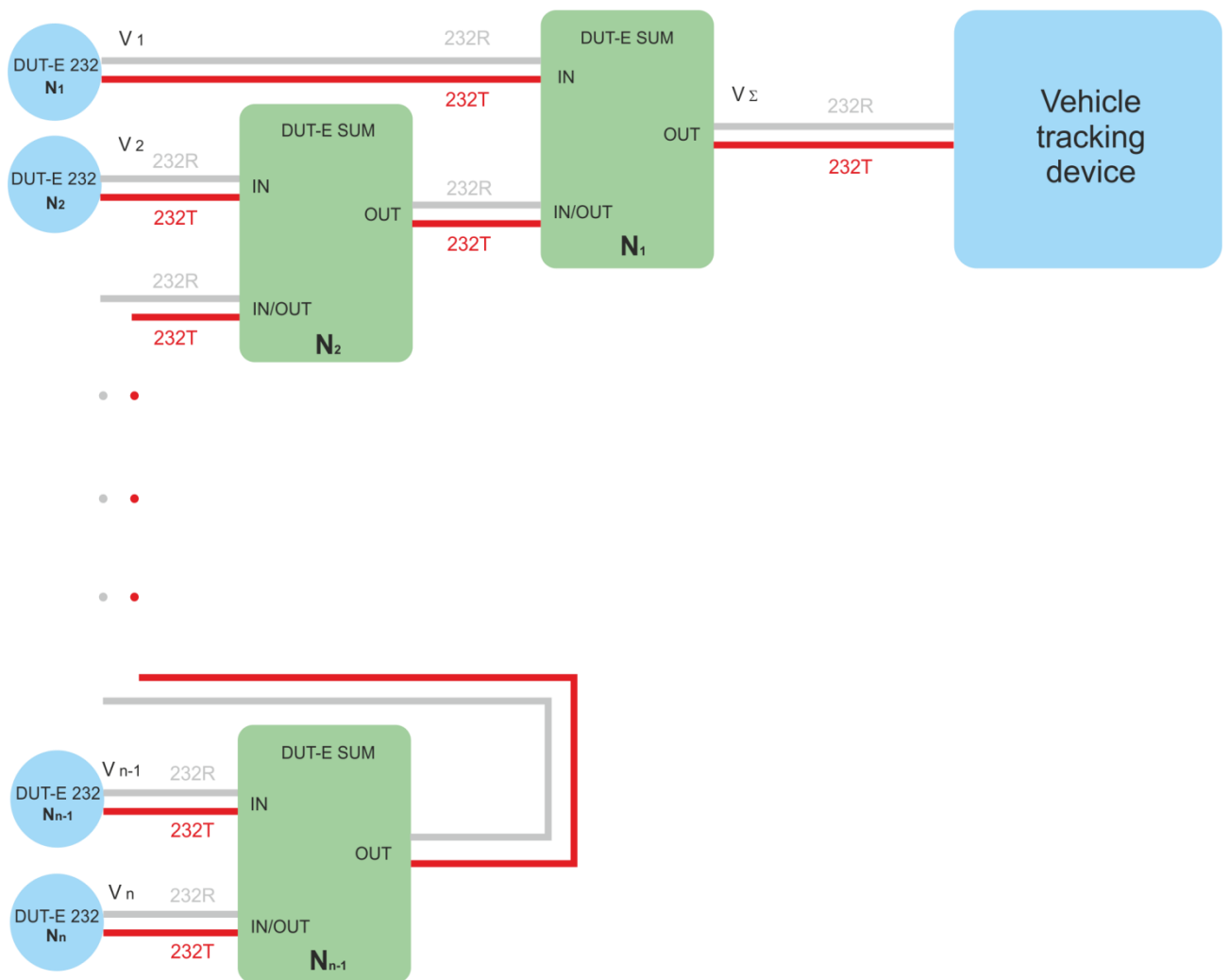

b) Connection scheme of three and more DUT-E 232 (summators cascading)

Figure 23 — DUT-E SUM 232 connection schemes

2.4.2 DUT-E AF readings totalizing

[DUT-E SUM AF summator](#) designed by [Technoton](#) is used together with DUT-E AF sensors on vehicles with two and more fuel tanks for measuring total amount of fuel (see figure 24).

ATTENTION:



- 1) DUT-E SUM AF summator operates only with DUT-E AF sensors with firmware version 3.5 and higher.
- 2) Fuel tank calibration table should be recorded into the internal memory of each sensor (see [3.10.7](#)).
- 3) Readings can be totalized both analog (voltage) and frequency output signal types of DUT-E AF.



Figure 24 — DUT-E SUM AF summator

DUT-E SUM AF output message contains total fuel volume (in liters) as a sum of the values measured by sensors connected to its **IN** and **IN/OUT** inputs.

Electrical connection of summators is carried out according to the diagrams provided in figure 25 and in compliance with wire assignment provided in table 8.

Two [DUT-E AF](#) sensors are connected to the single tracking device according to figure 25 a.

If there are three or more fuel tanks to be measured with DUT-E AF sensors, cascade connection can be used according to figure 25 b.

Quick splice connectors (ordered separately) are recommended for electrical connection of signal wires.

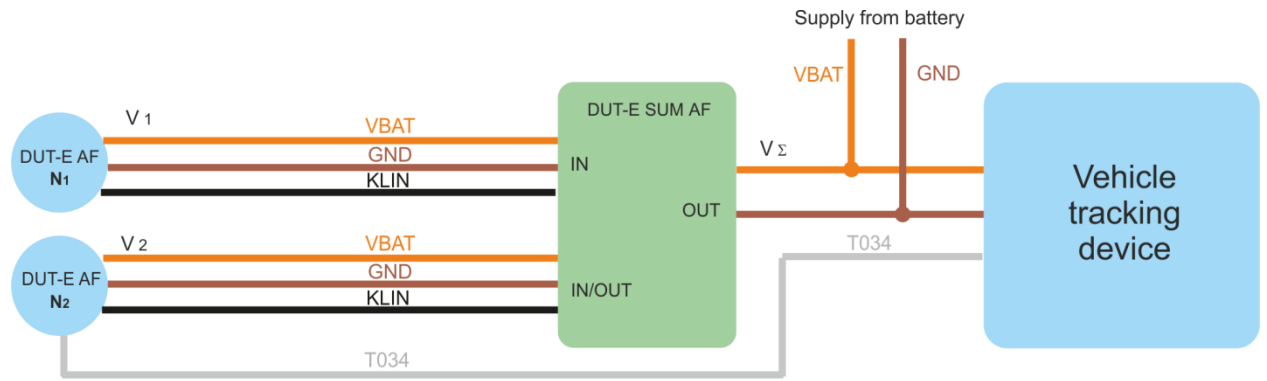

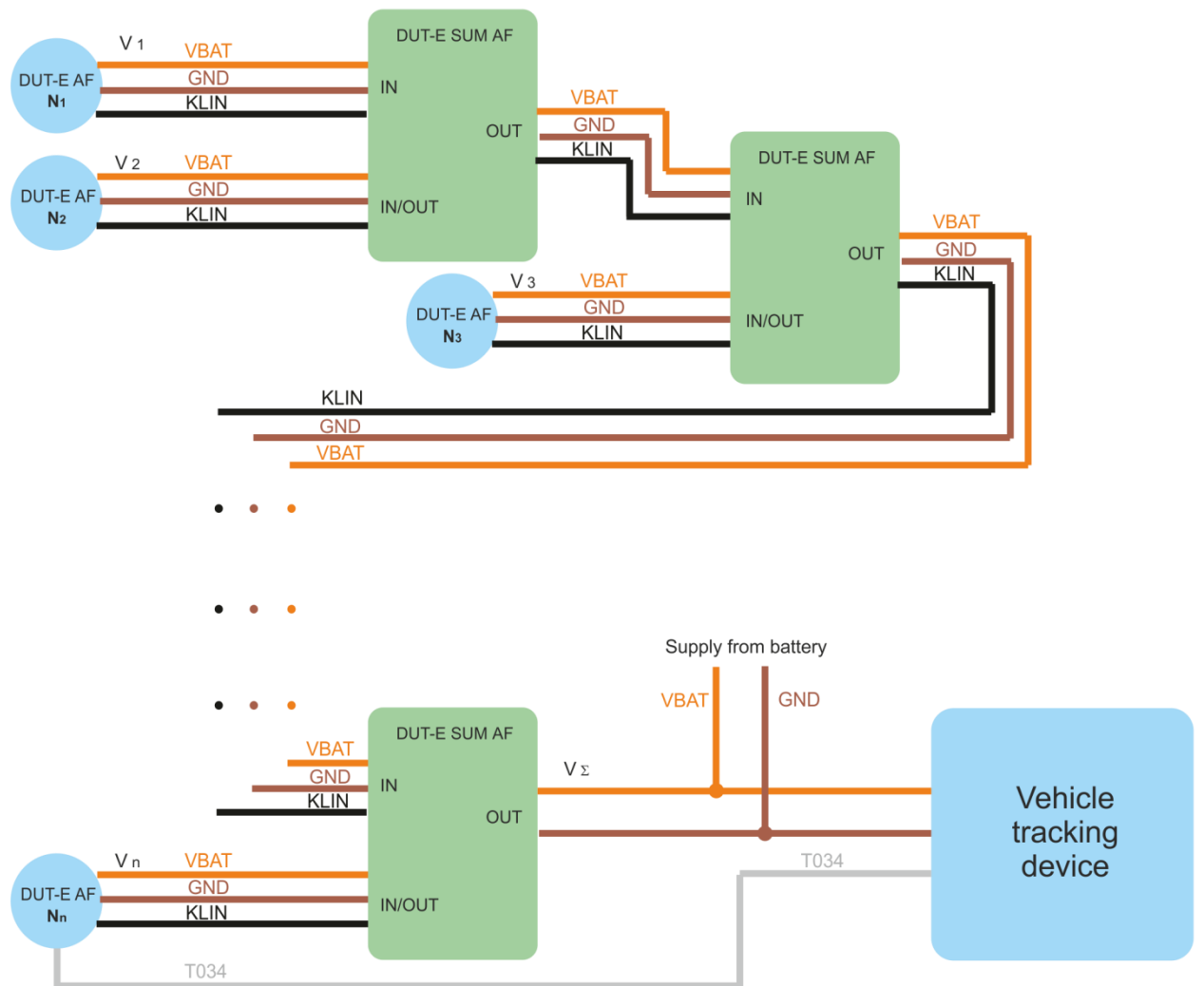

a) Connection scheme of two DUT-E AF sensors



b) Connection scheme of three and more DUT-E AF (summators cascading)

Figure 25 — DUT-E SUM AF connection schemes

Table 8 — DUT-E SUM AF wires assignment

Wire number	Wire marking	Wire color*		Assignment
1	VBAT	Orange		Power supply "+"
2	GND	Brown		Ground
3	KLIN	Black		K-Line (ISO 14230)

* [Manufacturer](#) reserves the right to change wire colors.

To get correct values DUT-E AF **Analog output** should be configured with [Service DUT-E](#) software (version 3.22 and higher). Configuration instructions:

- when totalizing readings of DUT-E AF in analog output mode select **U** output signal type for **all** sensors. Insert minimum (U_{\min} , V) and maximum (U_{\max} , V) signal values into correspondent fields.



ATTENTION: When totalizing readings of DUT-E AF in frequency output mode select **F** parameter value for **N_n** sensor from the **Output type** drop-down list. Select **U** for **N₁...N_{n-1}** sensors.

- select the highest address for **N_n** sensor at **Settings-Operation modes** (see [3.10.4](#)) module. Select consecutive network addresses for **N₁...N_{n-1}** sensors without missing addresses for the best and fastest totalizing performance (see figure 24).
- select **Sum** parameter value for **N_n** sensor from the second drop-down list. Any type (Level or Volume) can be set for **N₁...N_{n-1}** sensors.
- exit Service DUT-E since sensor is configured because the software is blocking data exchange between DUT-E AF.

2.5 Sealing

It is required to seal the sensor and cable connector with sealing cords and disposable plastic seals to prevent fuel thefts or unauthorized interference into [DUT-E](#) operation (see figure 26). Seals and cord are included into [DUT-E delivery set](#).



ATTENTION: Security sealing of AF/232/485 cable connector should be carried out after the configuration and calibration are finished (see [3](#))

To seal the sensor put the sealing cord through the special holes of the mounting plate and DUT-E body. Then put the ends of the cord through the holes in the center of the plastic seal body. Latching the seal will lock the cord. Seal removal will be impossible without its damaging.

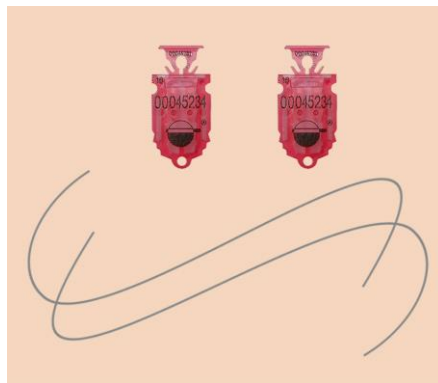

Figure 26 — Plastic seal* and sealing cord



WARNING: Sealing rope should not touch the fuel tank body!

* Design of the seal supplied within the delivery set can differ from the one displayed in figure 26.

3 Configuration of sensor using service adapter

Minimum/maximum measurement level **calibration** is required for correct operation of DUT-E AF/232/485 as well as **configuration** according to specific operating conditions and requirements of tracking devices/data loggers.



ATTENTION: DUT-E A5/A10/F/I do not require any calibration and configuration.

Calibration and configuration is carried out with [SK DUT-E](#) or S6 SK service adapter (ordered separately).

Check out [DUT-E installation video](#) for configuration instance.

3.1 SK DUT-E purpose of use

SK DUT-E service adapter is designed to configure DUT-E AF/232/485 sensors and also for data exchange between the PC and DUT-E.

Before starting with service adapter, it is necessary to download software from <https://www.jv-technoton.com/> (section [Software/Firmware](#)) and install it to PC:

- USB driver;
- Service DUT-E software.

Service DUT-E software functions:

- checking and modifying sensor settings;
- sensor calibration;
- fuel tank calibration;
- saving sensor configuration profile to PC;
- upload previously saved configuration profile from PC to sensor;
- monitor sensor output data;
- run sensor diagnostics;
- update sensor firmware.

3.2 Hardware requirements

For work with Service [DUT-E software](#), you need a separate PC (desktop or laptop) on which **only** [Technoton](#) service software that meets the following minimal requirements is installed:

- Windows XP/Vista/7/8/8.1/10 operating system of X32/X64 bit depth;
- CPU — Intel Core i3, dual-core, 2.0 GHz;
- RAM — 4 Gb;
- availability of USB 2.0 port;
- display resolution 1366x768.



ATTENTION: Service adapter operation is possible only after preliminary installation of [USB driver](#).

3.3 Service adapter components

3.3.1 Exterior view and delivery set



- 1** - universal service adapter;
- 2** - SK DUT-E specification;
- 3** - USB A-B cable;
- 4** - CAN service cable;
- 5** - RS-485 service cable;
- 6** - RS-232 service cable;
- 7** - AF service cable.

Figure 27 — SK DUT-E delivery set

3.3.2 Universal service adapter

Universal service adapter (hereinafter adapter) is designed to transmit data between [DUT-E](#) sensors and PC.

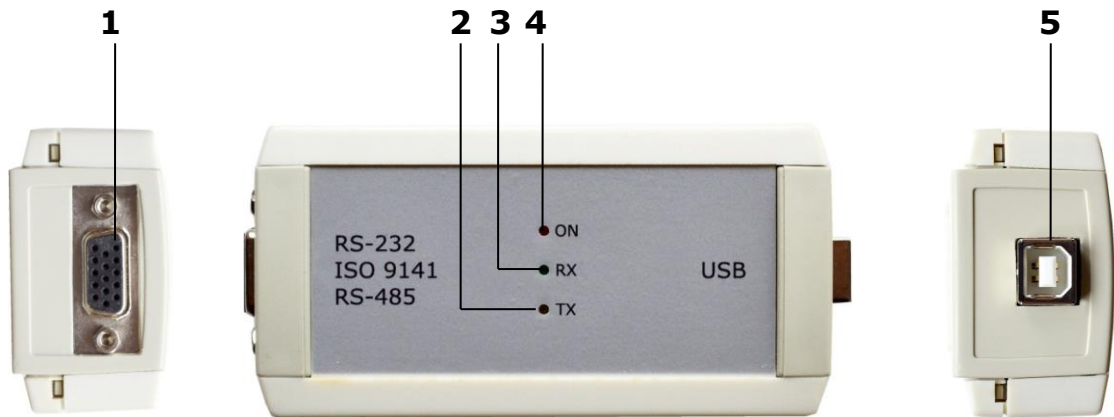

- 1** – RS-232/ISO 9141/RS-485 socket for DUT-E connection;
- 2** – TX yellow LED indicator of data transmitted to DUT-E;
- 3** – RX green LED indicator of data received from DUT-E;
- 4** – ON red LED indicator of power supply;
- 5** – USB B port for PC connection.

Figure 28 — Adapter exterior view

3.3.3 USB A-B Cable

USB A-B cable is used for connection of PC and adapter (see figure 29)

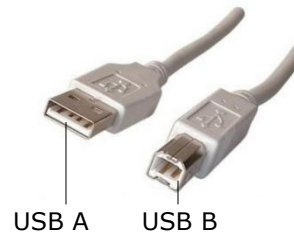
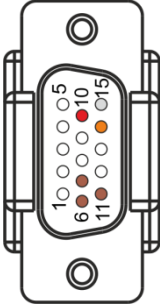





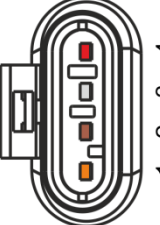





Figure 29 — USB A-B cable connectors

3.3.4 RS-485 service cable

RS-485 service cable used to connect adapter to DUT-E 485.

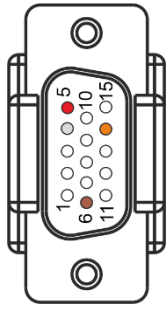



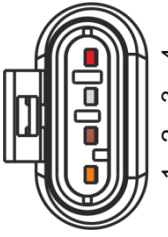



Table 9 — Pinout of RS-485 service cable connectors

View	Pin No	Wire		Signal		
		Marking	Color	Assignment	Type	
	6	GND		Brown	Ground	-
	7	GND		Brown	Ground	-
	10	485B		Red	Transmitted data	Serial, RS-485 interface
	11	SEL1		Brown	RS-485 selection	Discrete
	14	VBAT		Orange	Power supply	Analog, voltage 0...50 V
	15	485A		White	Received data	Serial, RS-485 interface
	1	VBAT		Orange	Power supply	Analog, voltage 0...50 V
	2	GND		Brown	Ground	-
	3	485A		White	Received data	Serial, RS-485 interface
	4	485B		Red	Transmitted data	Serial, RS-485 interface

3.3.5 RS-232 service cable

RS-232 service cable used to connect adapter to DUT-E 232.

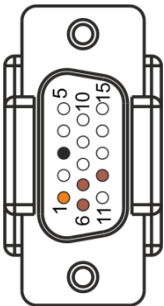



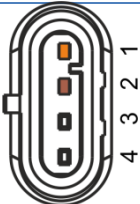

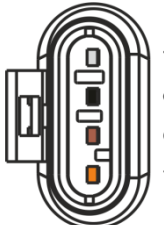



Table 10 — Pinout of RS-232 service cable connectors

View	Pin No	Wire		Signal		
		Marking	Color	Assignment	Type	
	5	232T		Red	Transmitted data	Serial, RS-232 interface
	4	232R		White	Received data	Serial, RS-232 interface
	6	GND		Brown	Ground	-
	14	VBAT		Orange	Power supply	Analog, voltage 0...50 V
	1	VBAT		Orange	Power supply	Analog, voltage 0...50 V
	2	GND		Brown	Ground	-
	3	232R		White	Received data	Serial, RS-232 interface
	4	232T		Red	Transmitted data	Serial, RS-232 interface

3.3.6 AF service cable

AF service cable used to connect adapter to DUT-E AF.

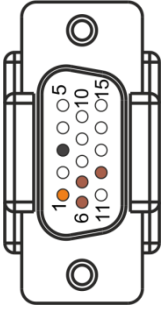





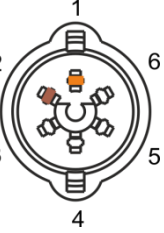





Table 11 — Pinout of AF service cable connectors

View	Pin No	Wire		Signal		
		Marking	Color	Assignment	Type	
	1	VBAT		Orange	Power supply	Analog, voltage 0...32 V
	3	KLIN		Black	K-Line	Serial, ISO 14230 standard
	6	GND		Brown	Ground	-
	7	GND		Brown	Ground	-
	1	VBAT		Orange	Power supply	Analog, voltage 0...32 V
	2	GND		Brown	Ground	-
	1	VBAT		Orange	Power supply	Analog, voltage 0...32 V
	2	GND		Brown	Ground	-
	3	KLIN		Black	K-Line	Serial, ISO 14230 standard
	4	T034		White	Fuel level	Analog, voltage 0...9 V

3.3.7 CAN service cable

CAN service cable is a spare one. For the sensors described in this document it is irrelevant.

Table 12 — Pinout of CAN service cable connectors

View	Pin No	Wire		Signal		
		Marking	Color	Assignment	Type	
	1	VBAT		Orange	Power supply	Analog, voltage 0...32 V
	3	KLIN		Black	K-Line	Serial, ISO 14230 standard
	6	GND		Brown	Ground	-
	7	GND		Brown	Ground	-
	12	SEL2		Brown	K-Line selection	Discrete
	1	VBAT		Orange	Power supply	Analog, voltage 0...32 V
	2	GND		Brown	Ground	-
	1	VBAT		Orange	Power supply	Analog, voltage 0...32 V
	2	GND		Brown	Ground	-
	5	KLIN		Black	K-Line	Serial, ISO 14230 standard

3.4 Software installation

3.4.1 USB driver installation



ATTENTION: Service adapter operation is possible only after preliminary installation of USB driver.

- 1) [Download](#) and unzip the file containing USB driver. Run CP210xVCPInstaller_x64.exe (for x64 architecture Windows) and or CP210xVCPInstaller_x86.exe (for x32 architecture Windows) from unzipped folder).
- 2) Press in CP210x USB to UART Bridge Driver Installer window (see figure 30) to continue installation.



Figure 30 – CP210x USB to UART Bridge Driver Installer window

- 3) After accepting User License Agreement (see figure 31) the installation process will be continued. During installation, please follow the instructions of Bridge Driver Installer.

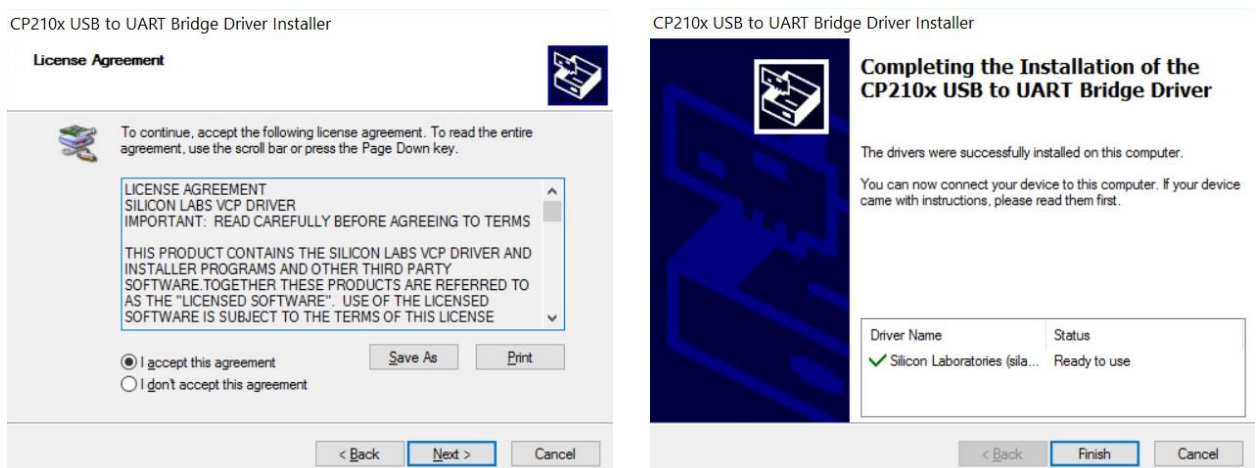

Figure 31 – Acceptance of the License agreement and successful installation notification USB driver window

3.4.2 Service DUT-E software installation

To install the software, [download](#) and run necessary installation file Setup Service DUT-E vX.XX.exe

Note — X.XX corresponds to the version of software. The latest version described in the present manual is 3.26.

Select installer language out of the drop-down list (see figure 32).



Figure 32 — Installer language selection

Click **Next >** button to start installation of the software (see figure 33) and follow the instructions.



Figure 33 — Service DUT-E installation wizard window

The following window will indicate the process of installation of Service DUT-E files. Since the installation of Service DUT-E software is finished PC is ready for service adapter connection and operation (see figure 34).

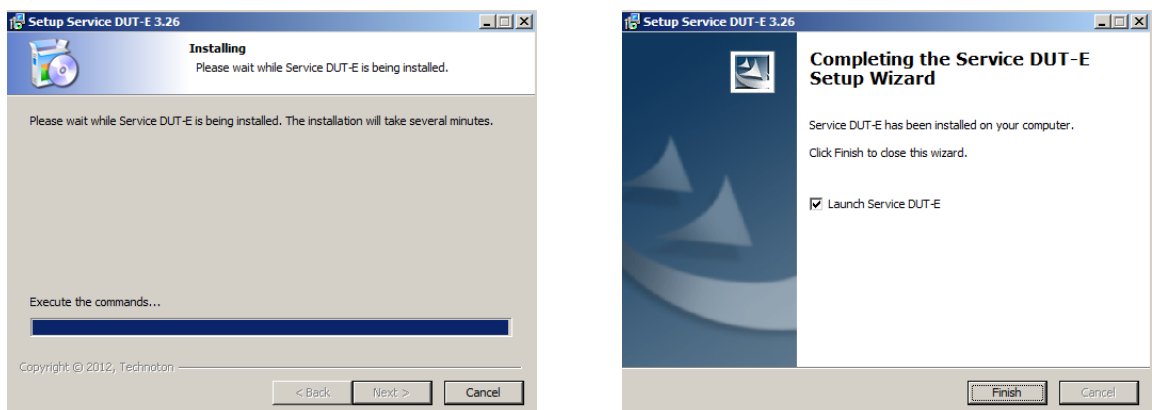

Figure 34 — Service DUT-E installation progress

3.5 Service adapter connection

3.5.1 Exterior inspection prior to connection

It is necessary to conduct service adapter exterior inspection for the presence of the possible defects arisen during transportation, storage or careless use:

- visible damages of the adapter body;
- connector and insulation damages of cables.

Contact the supplier if any defects detected.

3.5.2 Operation restrictions

Avoid the following when connecting service adapter to the sensor mounted into the fuel tank of the [Vehicle](#):

- ingress of fuel and lubricants and moisture to the contact pins of adapter slots or connectors of cables;
- potential damage of the adapter and cables by the rotating and heating elements of the engine.



ATTENTION: To avoid any service adapter faults in communication between PC and sensor make sure there are no sources of electromagnetic interference close to the workplace (running electric motors, welding equipment, high-power transformers, power lines, etc.).

3.5.3 Connecting DUT-E to PC



ATTENTION: Prior to connecting DUT-E to a PC, it is necessary to turn off electrical circuits of the [Vehicle](#) (when configuring DUT-E installed on Vehicle). To do this, use the battery switch or remove the battery terminals.

[DUT-E](#) sensors are connected to PC through service adapter according to the connection schemes (see figure 35).

Follow the instructions:

- 1)** Connect SK DUT-E adapter to DUT-E.
It is connected with the service cable corresponding to the model of the sensor to be configured: RS-232/RS-485/AF (see figure 35 a, b, c).

Notes

1 While configuring DUT-E 232/485 it is power-supplied through USB A-B cable from USB-port.

2 While configuring DUT-E AF power supply should be additionally connected from accumulator battery or other power source.

- 2)** Connect the adapter with USB A-B cable to a vacant USB port of the PC.
Note – it is allowed to connect adapter to USB-port of your PC after turning on power supply of sensor and running Service DUT-E software.
- 3)** Connect power supply and ground wires to vehicle electrical system or battery.
- 4)** Power on the vehicle (battery).

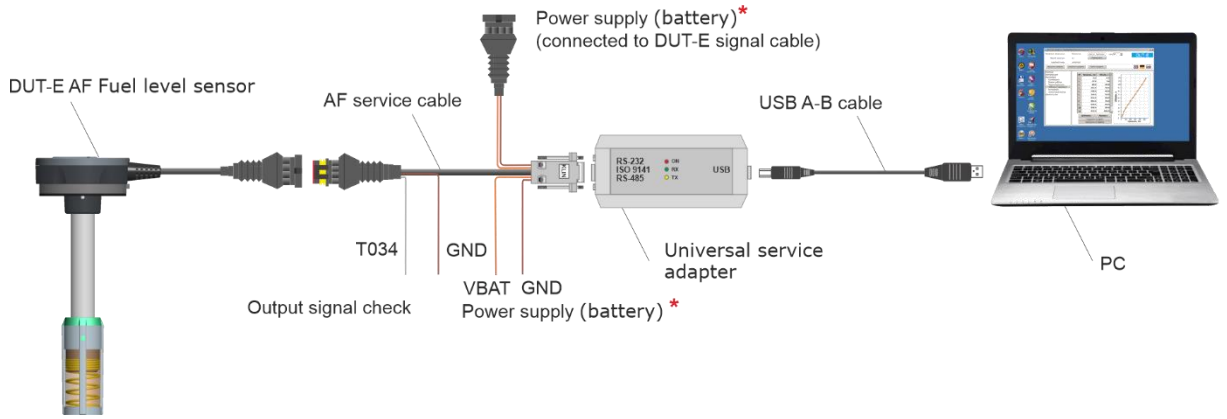

a) DUT-E AF connection

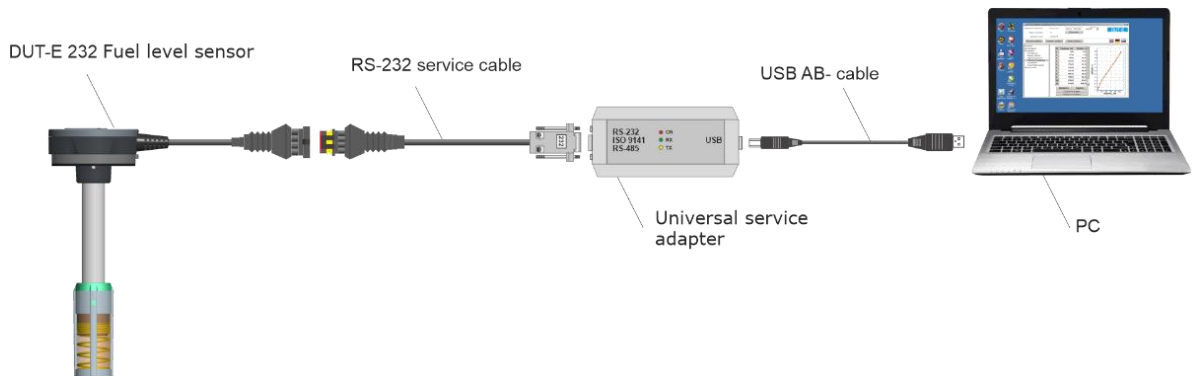

b) DUT-E 232 connection

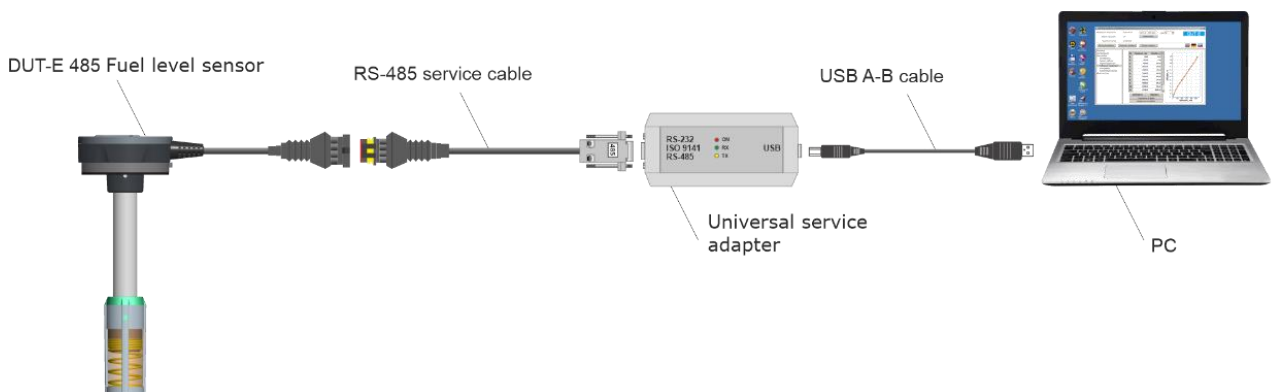

c) DUT-E 485 connection

Figure 35 — DUT-E to PC connection schemes while using SK DUT-E

* For connecting power supply (battery) you can choose any of marked places.

3.6 Operation test

Windows automatically detects adapter connected to PC’s USB port as USB device and enables virtual COM port driver for it. The virtual COM port will be displayed in the list of ports of Windows Device manager (see figure 36).



ATTENTION: It is recommended to untick power save check box for Service DUT-E in the virtual COM-port properties for energy safety purpose (see figure 36 b).

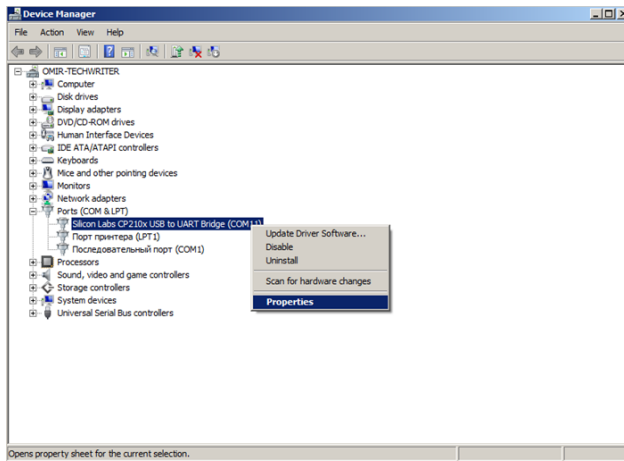

a) selecting port properties

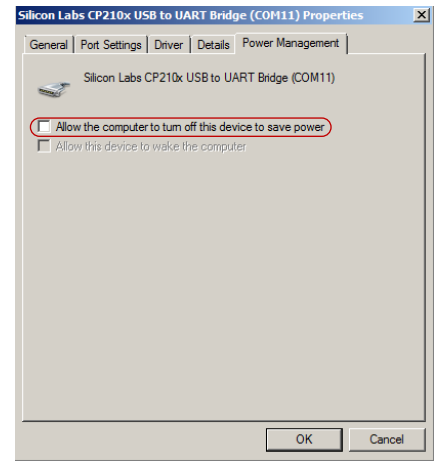



b) disabling power save option

Figure 36 – Virtual COM-port configuration in Device manager

Service adapter is ready to use since the power is on. See table 13 for signal description of LED indicators located on the adapter.

Table 13 – Adapter LED signals description

LED Indicator			Signal description
Marking	Status	Light color	
ON		Red	Power supply is on
	No signal		Power supply is off (or voltage is less than minimum required)
RX		Green	DUT-E data is being received
	No signal		No data from DUT-E
TX		Yellow	Data is being transmitted to DUT-E
	No signal		No data to DUT-E

3.7 Software launch



[Service DUT-E](#) software is launched with  desktop shortcut created during installation.

To enable connection between the sensor and PC connect adapter to USB port of PC and tick connection checkbox in the left from COM-port parameters field.

Note — when connecting [DUT-E AF](#) firstly select network address from the drop-down list ADDR (see figure 37).

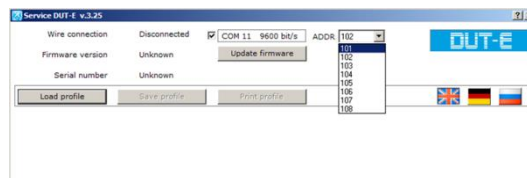

Figure 37 — Network address selection for DUT-E AF

Software will automatically change the connection status to “Connected”. Firmware version, serial number of the DUT-E sensor, virtual COM port number will be displayed as well as baud rate for RS-232, RS-485 or K-line connection (see figure 38). LED indicators of the adapter will display signals according to table 13.

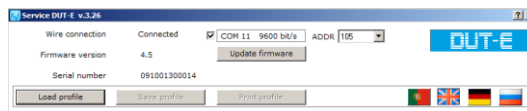

Figure 38 — Service DUT-E main window with sensor connection established

3.8 User interface and initial setup

[Service DUT-E](#) user interface consists of **Horizontal menu**, **Vertical menu**, **Connection status area** and **Information and configuration area** (see figure 39)

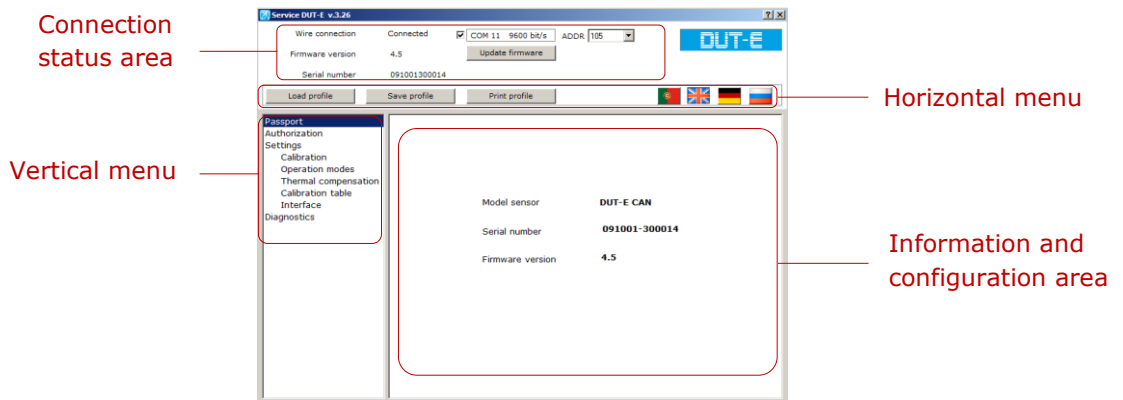

Figure 39 – Service DUT-E user interface

The top left area is **Connection status area** which displays current connection status of the sensor (Connected/Disconnected), firmware version and serial number of the connected [DUT-E](#) sensor, network address selection drop-down list (ADDR) and firmware update button.

Note – network address selection drop-down list (ADDR) is not displayed when DUT-E 232/485 connected.

Horizontal menu located under Connection status area provides following options:

- profile options (loading profile, saving profile, printing profile);
- selection of interface language.

Vertical menu is located at the left side of the window and used for selection of sensor profile entries which are displayed in **Information and configuration area** at the right side of the window. Vertical menu also contains Diagnostics and Fuel tank calibration entries.

The only initial setting required is selection of user interface language.

3.9 Operations with DUT-E profile

[Service DUT-E](#) software is designed for managing [DUT-E](#) sensor profile (hereinafter profile).

Profile is combination of specification data, configurations and settings of DUT-E sensor and vehicle it is mounted on.

Software can operate profiles in both DUT-E connected and autonomous modes. In autonomous mode, previously saved profiles can be loaded and modified.



ATTENTION: The following Service DUT-E operation description is compiled for DUT-E connected mode. While in autonomous mode of Service DUT-E some features and options are not available.

Profile can be saved as a file on PC's hard drive or saved to internal memory of connected DUT-E or printed if this is required.

3.9.1 Load profile

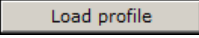
The following options of profile loading are available on  button click (see figure 40):

- from disk;
- default;
- from sensor.

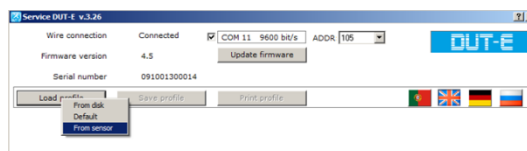

Figure 40 — Profile loading

Previously saved profile can be loaded from hard drive or removable disk when **From disk** option is selected.

Profile with default DUT-E settings is loaded when **Default** option is selected. This profile lets the user to get acquainted with software without establishing sensor connection.

Profile of the connected DUT-E sensor is loaded when **From sensor** option is selected.



ATTENTION: File extension of DUT-E profile is ***.dpf**

3.9.2 Save profile

The following options of profile saving are available on  button click (see figure 41):

- to file;
- to sensor.

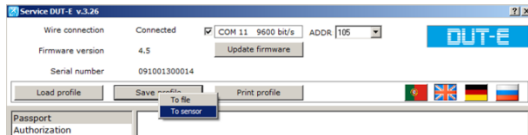

a) selection of saving option

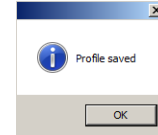

b) profile saved

Figure 41 — Saving profile

Select file location and enter file name when saving profile **To file**. The saved profile can be uploaded to any other DUT-E sensor of the same modification.

All the setting modifications will be saved to sensor's internal memory when saving profile **To sensor**.

The software will prompt authorization dialogue (see [3.10.2](#)) on saving profile to sensor or on calibration if user has not been yet authorized (see figure 42).

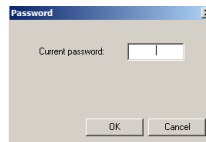
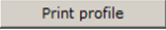

Figure 42 — Password request

Note — default password for DUT-E sensors is **1111**. It is stated in sensor specification in factory settings list.

3.9.3 Print profile

This feature converts loaded profile into HTML document.

After clicking  button select location for saving of ***.html** file with sensor profile data. Then this file can be viewed or printed.

See [annex C](#) for [DUT-E](#) profile printed copy example.



RECOMMENDATION: It is recommended to attach profile hard copy to sensors Specification for further tracking of setting modifications made for particular sensor.

3.10 Vertical menu description

3.10.1 Passport

When the profile is loaded from the connected sensor **Passport** entry shows the following information on connected [DUT-E](#) (see figure 43):

- sensor model;
- serial number;
- firmware version.

This data cannot be edited by the user. Serial number and firmware version is also displayed at connection status area of the window.

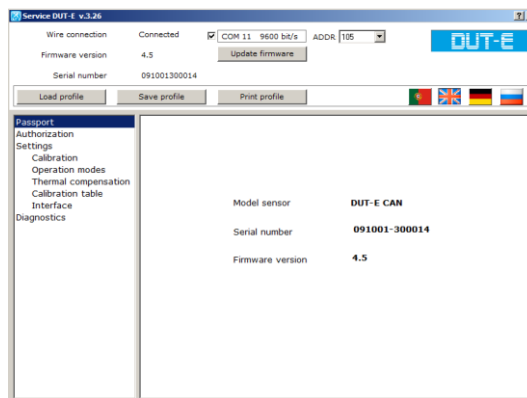

Figure 43 — Passport module

3.10.2 Authorization

Authorization module provides access to [DUT-E](#) settings modification.

[Service DUT-E](#) users can be divided into two groups:

- guest — can view DUT-E settings but cannot modify them;
- specialist — can view and modify DUT-E settings.

Unauthorized user has guest rights. To get specialist rights user should log in with current password and click **Set** button (see figure 44).

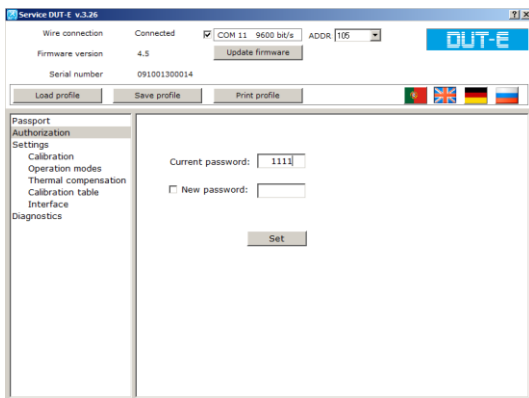

a) authorization with current password

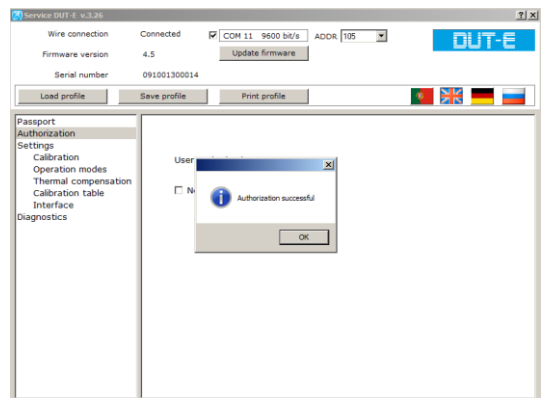

b) successful authorization notification



c) invalid password notification

Figure 44 — User authorization

To set new password enter current password, tick new password box, enter new password and click **Set** button (see figure 45).

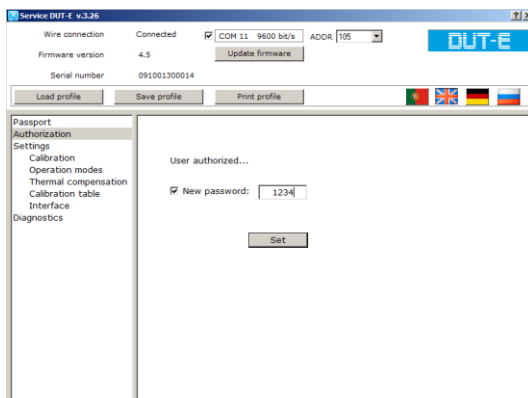

a) entering new password

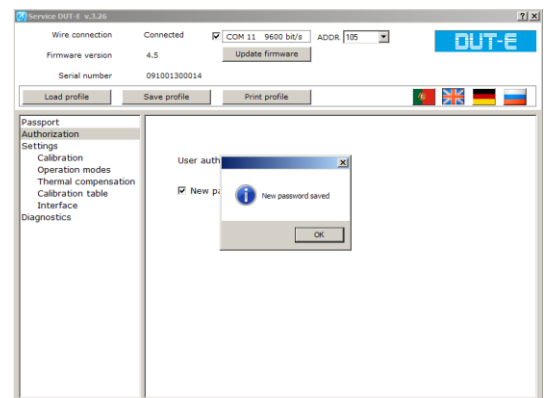

b) confirmation of successful password modification

Figure 45 — Setting new password

ATTENTION:

Contact [Technoton technical support](mailto:support@jv-technoton.com) at support@jv-technoton.com.by if the password is lost.

Requirements for password recovery request:



- scan copy of the request signed and sealed by the official representative of the company the sensor been purchased by should be attached;
- request should contain serial number and manufacture date of the sensor;
- email should contain password recovery code in a text form (not a screenshot!);
- email should contain full name and contact e-mail of a person who should receive the recovered password.

To generate password recovery code (see figure 44) use **Ctrl+F10** shortcut in the current password field of authorization dialogue (see figure 46).

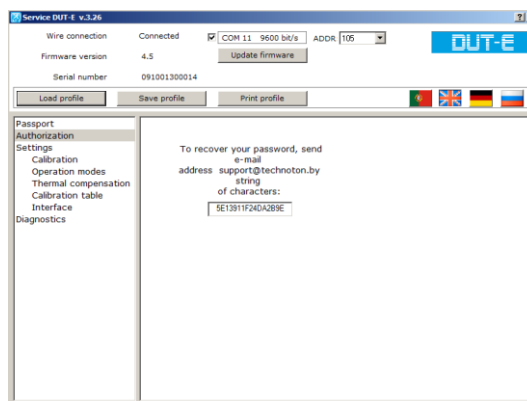

Figure 46 — Generating password recovery code

3.10.3 Settings - Calibration

Calibration is required for correct operation of **DUT-E**. Calibration is conducted to determine minimum and maximum levels of measurement of fuel in the tank.

IMPORTANT:



- 1) Before mounting **DUT-E** AF/232/485 in the tank, **sensor calibration** for the specific type of fuel used **is obligatory!**
- 2) Another calibration of DUT-E AF/232/485 is obligatory **after cutting/extension** of its measuring probe.

To calibrate minimum and maximum level follow the procedure:

- 1) Get the measuring probe (tubes) out of the fuel.
- 2) Wait for 30...60 seconds so that all the fuel run off the probe.
- 3) Measure the probe length **L (mm)** from the edge to the drain holes (see figure 47 a).
- 4) Enter the value into **Actual length of sensor after trimming** field of Settings-Calibration entry (see figure 47 b).
- 5) Wait for 3...5 seconds for sensor readings stabilization.
- 6) Click for minimum level calibration.



ATTENTION: When calibrating sensor to minimum level, there should not be fuel residues on surface of tubes of probe.

- 7) Dip the probe's tubes fully into the fuel.
- 8) Wait for 3...5 seconds for sensor readings stabilization.
- 9) Click for maximum level calibration.
- 10) Min/max calibration is finished.

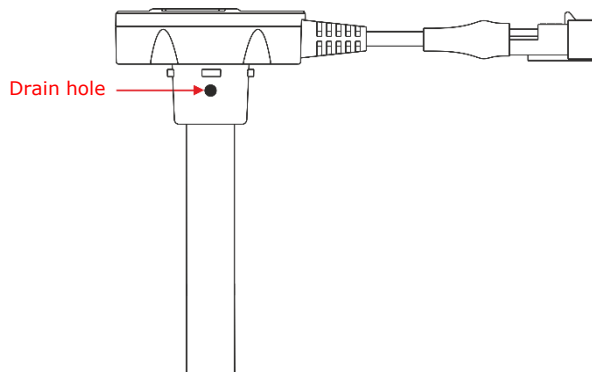

a) measuring probe length

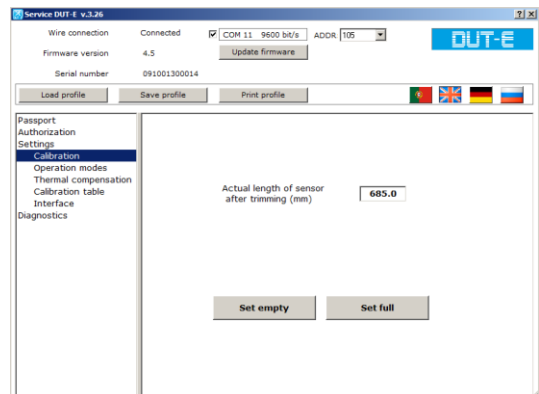

b) Settings-Calibration entry

Figure 48 — DUT-E min/max calibration

3.10.4 Settings – Operation modes

Operation modes entry contains settings to configure sensor for operation in particular conditions with compliance of tracking device requirements (see figure 48).

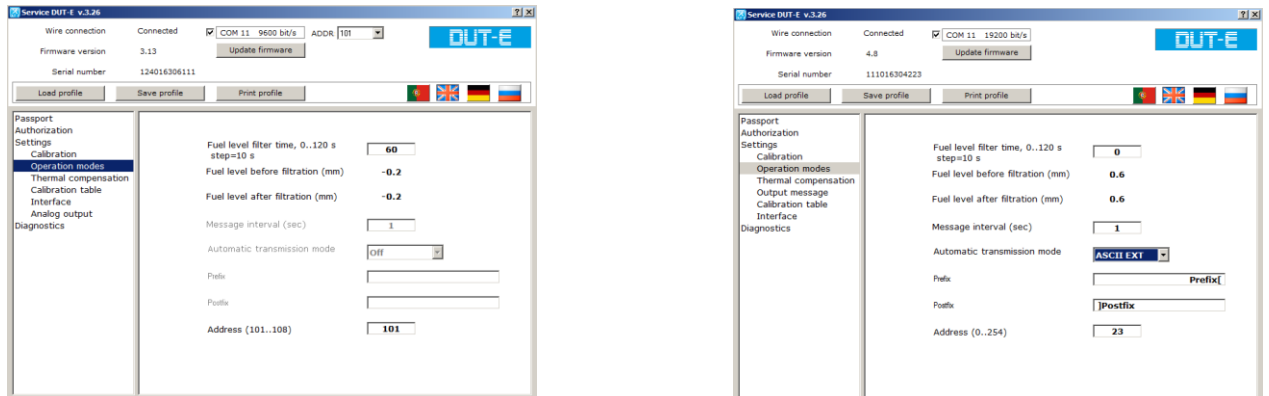

a) DUT-E AF

b) DUT-E 232/485

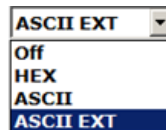

c) Automatic transmission mode drop-down list

Figure 48 – Operation mode configuration

1) Fuel level filter time – time interval preceding the data transmission. Fuel level value is smoothed during this interval. Thus, fuel level value transmitted by sensor to the tracking device is not instantaneous and is averaged over a certain period of time.

Parameter value range is 0...120 seconds with 10 second step. Default value is 60 seconds.

Setting this parameter is very important for [DUT-E](#) mounted on vehicles operated on hilly surfaces.

2) Message interval* – time period the sensor automatically send output message to the tracking device.

Parameter value range is 1...255 seconds with 1 second step. Default value is 1 second.

3) Automatic transmission mode* – defines sensor output message type:

- **Off** - no automatic message transmission, sensor waits for tracking device request;
- **HEX** - automatic message transmission in binary format (used by default);
- **ASCII** - automatic message transmission in text format;
- **ASCII EXT** - automatic message transmission in extended text format. Additional **Prefix** and **Postfix** configurable parameters are available for this mode to insert required header or ending of the message.

4) Address** - provides DUT-E with network address when several operate via single bus (network). The following addresses are set by the [Manufacturer](#) by default:

- DUT-E 485 - two last digits of the sensor serial number;
- DUT-E AF - 101.

* Only for DUT-E 232/485.

** Only for DUT-E AF/485.

3.10.5 Settings – Thermal compensation

Temperature extension/shrinking of fuel cause by change of its temperature, leads to change of fuel volume in fuel tank. As result – sensors transmit to tracking/monitoring unit information on rising/lowering fuel level.

DUT-E AF/232/485 makes recalculation of fuel level – automatic temperature correction, which recoups temperature extension/shrinking of fuel.

By default, temperature correction function is turned off. To turn it on, tick the box **Thermocorrection**. In the field, which will appear next to the box, please enter thermal compensation coefficient (see figure 49).

Thermal correction coefficient $K_{ther.corr.}$ is defined, **when the feature of thermal correction is disabled**, according to formula (1):

$$K_{ther.corr.} = (-1) \cdot \frac{(V_{T_{max}} - V_{T_{min}}) \cdot 100}{(T_{max} - T_{min}) \cdot V_{T_{min}}} \quad (1)$$

where T_{min} and T_{max} – respectively the minimum and the maximum measured values of fuel temperature in the tank during 24 hours;

$V_{T_{min}}$ and $V_{T_{max}}$ – measured values of fuel volume in the tank with minimum and maximum fuel temperature respectively.

IMPORTANT:

- 1) It is recommended to determine Values $V_{T_{min}}$, $V_{T_{max}}$, T_{min} , T_{max} by data on [Server](#).
- 2) When measuring values $V_{T_{min}}$, $V_{T_{max}}$, T_{min} , T_{max} during 24 hours follow the requirements:



- thermal correction feature must be off in the sensor which is being configured;
- Vehicle is not moving with engine off.
- Ambient temperature should correspond to normal operating conditions of the [Vehicle](#).
- Tank should be filled with fuel not less than 10 % of the total fuel volume.
- There should be the same fuel volume in the tank (refueling or draining is not allowed).

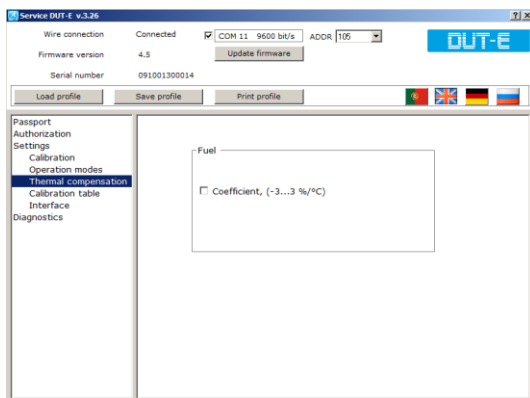

a) disabling the feature

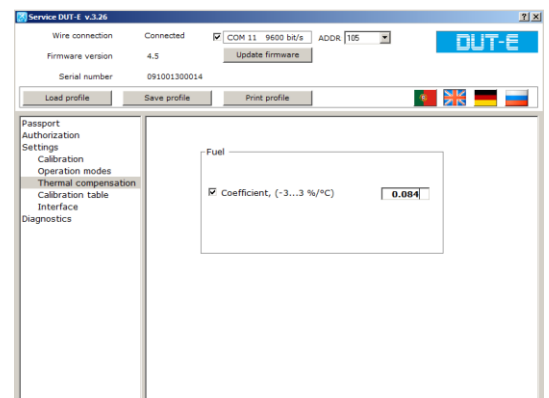

b) inserting coefficient

Figure 49 – Thermal compensation setting

3.10.6 Settings – Output message

One of the following output value types available for DUT-E 232/485 (see figure 50):

- fuel level in standard (normalized) units (0...1000);
- fuel level in millimeters (mm), 0.1 mm step;
- fuel volume in liters (L), 0.1 l step;
- fuel volume in percentage (%), 0.4 % step.

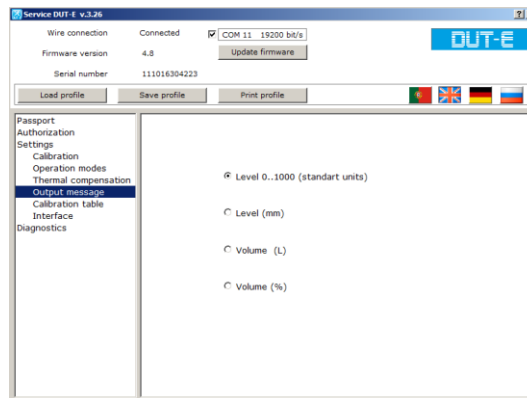

Figure 50 – Selection of output value type for DUT-E 232/485

3.10.7 Settings – Calibration table

This submenu is used for storing calibration table for particular [Vehicle](#) into DUT-E AF/232/485 sensor's internal memory. The sensor will recalculate level of fuel into volume of fuel on the basis of this table.



ATTENTION: Without storing calibration table into sensor's memory [DUT-E AF/232/485](#) will show incorrect data on fuel volume in liters, [DUT-E 232/485](#) show incorrect data in percentage. When summarizing signals from several [DUT-E AF/232](#) it is obligatory to store calibration table into each sensor.

Calibration table is based on values, received when performing **tank calibration**. This procedure consists of refilling fuel tank with certain portions of fuel from empty to full state (see video [Installing fuel level sensor](#)).



IMPORTANT: to measure volume of fuel portions used to refill fuel tank, use containers with accuracy error not more than **0.25 %**.

To make fuel tank calibration correctly, where the sensor is installed, it is required to follow the procedure:

- vehicle being equipped should not be loaded and should be parked on even horizontal surface;
- fuel tank should be empty;
- vehicle's tires should be of standard size and type for this model (replacement of standard wheels by wheels of non-standard type and size after the calibration procedure is performed results in decreasing accuracy of measurement or another calibration is needed);
- pressure in tires should be within allowed range for this model;
- vehicle should not move, ignition is turned on, engine not running;
- between to consequent tank refilling operations, please, wait at least 60 seconds.



RECOMMENDATION: Tank calibration using [DUT-E ATS automatic calibration station](#) reduces the calibration error down to $\pm 0,5$ % of the tank volume; labor input and time needed for the tank calibration are reduced by 2...3 times (see [DUT-E ATS Operation manual](#)).

The data is entered as a table of correspondence between measured fuel level value (**Level (mm)** field) and fuel volume in the tank (**Volume (l)** field). Recommended number of table entries is 15. Max possible is 30 entries (see figure 51).

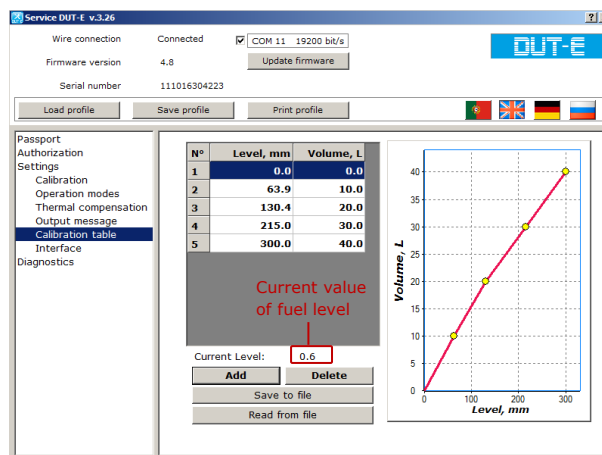



Figure 51 – Calibration table

ATTENTION:



- 1)** The number of calibration points is proportional to the measurement accuracy of fuel volume. The recommended number of calibration points is **not less than 15**. The maximum possible number of calibration points in sensor is **30**.
- 2)** The maximum possible fuel volume value that can be entered into the calibration table is limited by the value of **6553 l**.
- 3)** When creating the calibration table for the tank of **6553 l** capacity and higher, we recommend **to divide by 10** fuel volume values in each calibration point. Each of these values has **to be multiplied by 10** respectively at the [Server](#) for their correct displaying (see detailed recommendations in [annex B](#)).

Click  button to insert a new entry into the table and fill out the fields. Entries are automatically sorted from low to high fuel level value. To delete an entry highlight it and click  button.

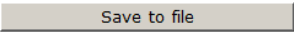
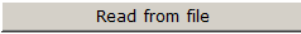
Clicking  button will allow saving the table as a ***.ttt** file. To load previously saved table from file click  button.



RECOMMENDATION: After the sensor mounting in the tank, the end of its measuring probe is located at a distance of 20...30 mm from the tank bottom. Some 10...30 l of the remaining fuel which is not consumed is usually left in this dead zone which is not accessible for monitoring. While creating the calibration table, we recommend to enter for its first point (level of 0.0 mm) the value of the fuel volume which is equal to the volume of not consumed fuel remaining in the tank.

3.10.8 Settings - Interface

Interface module (see figure 52) provides selection of baud rate for RS-232 (for DUT-E 232), RS-485 (for DUT-E 485) and K-line (for DUT-E AF) connections out of drop-down list:

- 4800 bit/s;
- 9600 bit/s;
- 19200 bit/s.

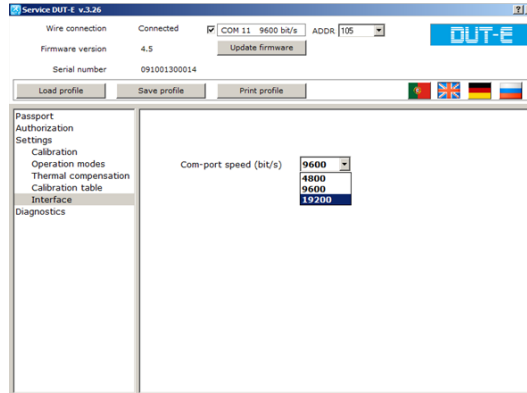
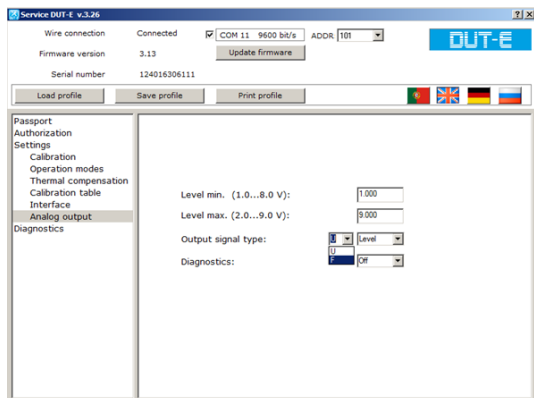

Figure 52 – Interface setting

3.10.9 Settings – Analog output

Analog output* module of Service DUT-E used for configuration of DUT-E AF output voltage range according to the voltage range of the tracking device input (see figure 53).



a) selection of signal type

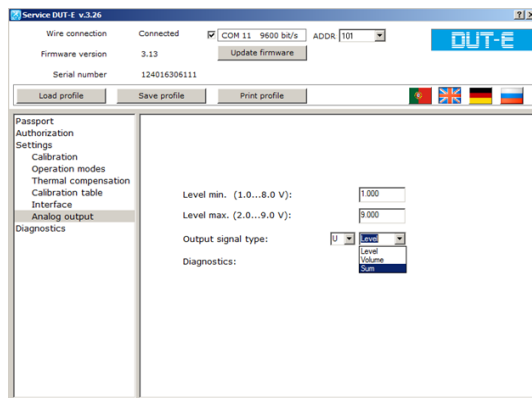

b) value type selection

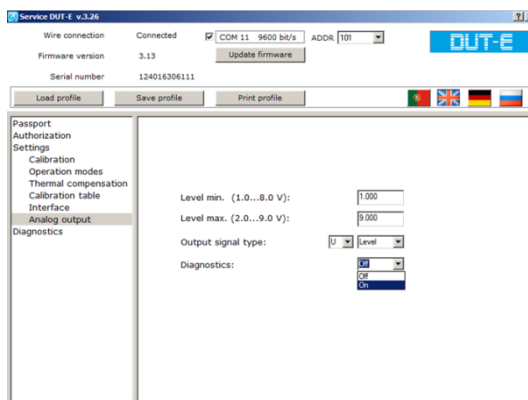

c) enabling diagnostics values of output signal

Figure 53 — DUT-E AF output configuration

The first drop-down list is for selection of **Output signal type** according to [1.4.2](#):

- **U** (voltage);
- **F** (frequency).

The second drop-down list for configuring value type:

- **Level** (fuel level in the tank);
- **Volume** (fuel volume in the tank);
- **Sum** (totalizing readings of several sensors according to [2.4.2](#)).

* Only for DUT-E AF.

To configure analog output, follow the instructions:

- 1)** Enter value of the lower range limit into **Minimum level (1.0...8.0 V)** field.
- 2)** Enter value of the higher range limit into **Maximum level (2.0...9.0 V)** field.

Diagnostics drop-down list (see figure 53 c) allows to enable/disable special output signal diagnostics values:

- **On** — for **U** mode 0.5 V and 9.5 V voltage are diagnostics values according to [table 17](#). For **F** mode 400 Hz and 1600 Hz frequency are diagnostics values according to [table 18](#).
- **Off** — special diagnostics output values are disabled. Default setting.

3.10.10 Diagnostics

Diagnostics module is used to view the current values and information on possible malfunction of the sensor (see figure 54 a).

Values displayed in **Fuel level (mm)** can be used for fuel tank calibration.

Analyzing the values of the parameters (fuel level in millimeters, standard units and liters) the correctness of the calibration and sensor settings can be verified.

Diagnostics tab will display the following information if there any malfunction:

- malfunction code;
- transcript of the malfunction code;
- possible malfunction reason.

[DUT-E COM Protocol](#) includes malfunctions codes according to table 14.

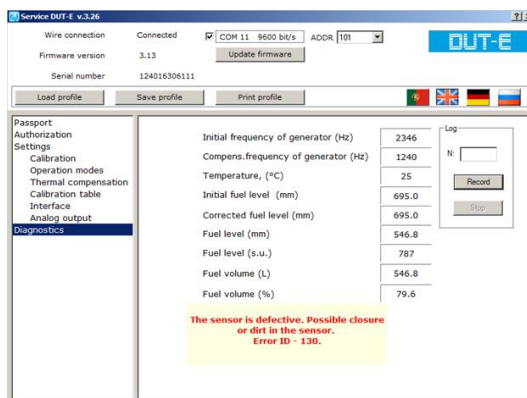

a) displaying current values and malfunction info

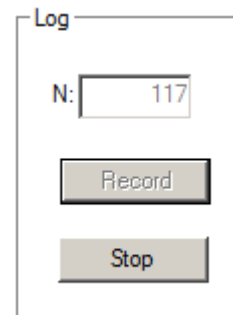

b) logging current values

Figure 54 – Diagnostics module

For analysis of sensor data, it is possible to log the values into the file. Recording interval is about 1 second. To log data, enter quantity of required log entries into **N** field of **Log** area and click **Record**. Click **Stop** to stop logging.

Recorded log files (***.txt**) are automatically stored to **\DUT_LOG** folder of the software installation directory on PC. File name consists of sensor serial number, date and time of log start.

See [annex D](#) for a log file example.

Table 14 — Malfunction codes

Malfunction code		Transcript of the malfunction code	Possible solution
Firmware version up to 2.9	Firmware version 2.9 and higher		
255	128 (-128)*	Calibration error	Check if the measuring probe actual size value is inserted correctly and (or) recalibrate the sensor**
254	129 (-127)*		
253	130 (-126)*	Short circuit in measuring probe tubes	Wash the measuring probe tubes with clean fuel, clean fuel tank of mud and water
252	131 (-125)*	Calibration error	Check if the measuring probe actual size value is inserted correctly and (or) recalibrate the sensor**
251	132 (-124)*	Hardware failure	Contact your supplier
250	133 (-123)*	Calibration error	Check if the measuring probe actual size value is inserted correctly and (or) recalibrate the sensor**
—	134 (-122)*		
<p>* Different malfunction code display.</p> <p>** Fuel tank calibration table should be recompiled and recorded all over again into DUT-E AF/232/485 sensor internal memory.</p>			

3.11 Firmware update



ATTENTION: DUT-E AF/232/485 firmware update should be done **only** to apply changes recommended by the [Manufacturer](#).



WARNING: When re-uploading firmware, power supply voltage of DUT-E AF should not drop out of 10...50 V range.

[DUT-E](#) firmware update procedure is started on button click. The button is located at Connection status area of [Service DUT-E](#) window (see figure 55).

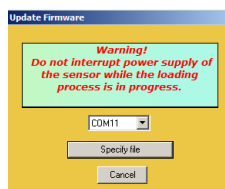

Figure 55 – Firmware update window

To cancel firmware update click button. To continue with firmware update, click and select firmware file (***.cod**) from the PC hard drive (see figure 56).



Figure 56 – Opening firmware file



ATTENTION: Check the details of firmware file to make sure it matches DUT-E modification!

Enter sensor password into the prompted dialogue window (see figure 57).

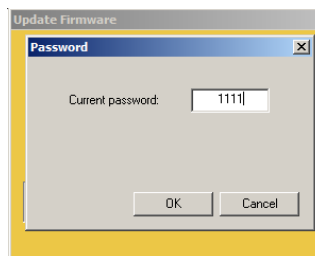

Figure 57 – Password request window

Firmware update process can last for several minutes (see figure 58).

ATTENTION:

Before the end of the update process it is **forbidden** to



- 1) Disconnect DUT-E from the adapter.
- 2) Disconnect adapter from the PC.
- 3) Power down the PC.
- 4) Run any resource-intensive applications on the PC.

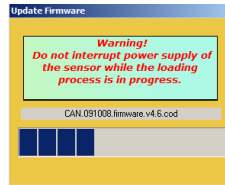



Figure 58 — Firmware file uploading to the sensor memory

Service DUT-E will display the new firmware version at Connection status area in case the update is successful. DUT-E is ready for further operation.

In case of any error occur check all the cable and adapter connections and retry. Contact [Technoton technical support](mailto:support@jv-technoton.com) at support@jv-technoton.com if another try is also unsuccessful.

3.12 Software shutdown and DUT-E disconnection

When configuration is made follow the instructions to disconnect [DUT-E](#) AF/232/485:

- 1) Save modified profile if necessary (see [3.9.2](#)).
- 2) Shutdown [Service DUT-E](#) software clicking  at the top left corner of the window.
- 3) Power down vehicle electrical system if the sensor is powered from it or switch off power supply of the sensor*.
- 4) Disconnect DUT-E service cable from the sensor connector.

Adapter can now be used for the next sensor connection (see [3.5.3](#)).

* This step is only applied for DUT-E AF.

4 Measurement accuracy check

4.1 Basic principles

DUT-E accuracy check test is conducted to determine the reduced and absolute error of fuel level measurement on the particular [Vehicle](#).

The procedure of DUT-E accuracy check requires filling/draining of the fuel tank and comparing sensor data with the actual amounts of filling/draining.

Fuel drain is carried with manual or mechanical pump.

Calibrated measuring containers must be used to determine the exact amount of drained/refilled fuel.



ATTENTION: The amount of any fuel filling/draining during the accuracy test should not be less than 20 % of total tank capacity.

4.2 Check tests procedure

Check tests should be carried out in the following order:

- 1)** Turn ignition on.
- 2)** Drain a fixed volume of fuel.
- 3)** Determine the exact amount of fuel with the calibrated measuring container.
- 4)** Record the data into the Check test report.
- 5)** Wait for the fuel getting still in the tank (for a stable [DUT-E](#) readings).
- 6)** Refuel the tank with the previously drained fuel.
- 7)** Record the data into the Check test report.
- 8)** When analyzing accuracy errors, "Drain" and "Refill" [Parameters](#) are estimated as a percentage relative to the total tank capacity.

See [annex A](#) for check test report template and error calculation formula.

5 Accessories

[Technoton](#) offers **high quality accessories** for mounting, connection and operation of [DUT-E](#) sensors.

5.1 MK DUT-E mounting kit

DUT-E mounting kit (hereinafter [MK DUT-E](#)) is used for sensor mounting into the fuel tank of vehicle or stationary tank. MK DUT-E is included into DUT-E delivery set. Extra mounting kits can be ordered separately if required.

DUT-E sensor is mounted quickly and accurately with MK DUT-E. See figure 59 for MK DUT-E components.

Mounting plate with SAE 5 bolt standard bore position can be preordered.

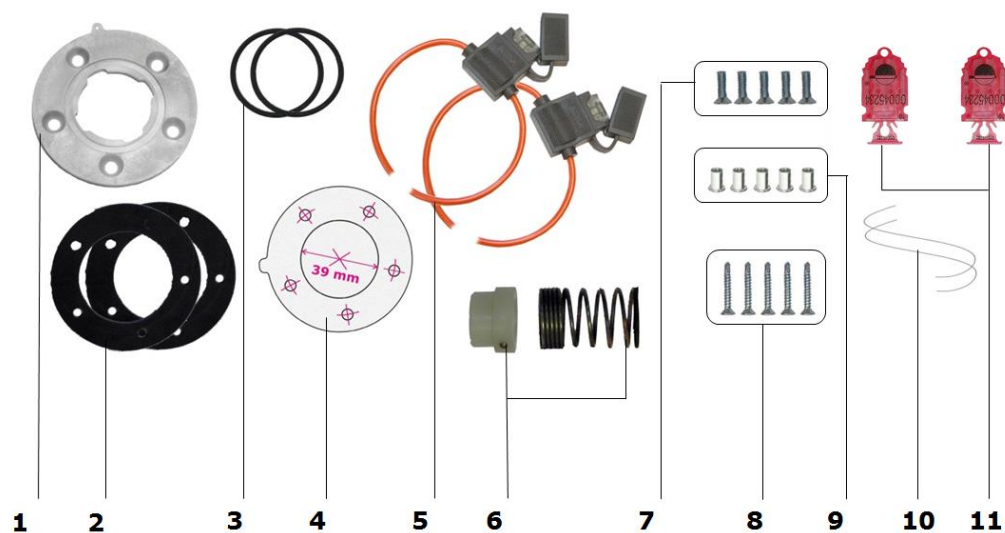

1	- plastic mounting plate	- 1 pc.;
2	- rubber gasket	- 2 pcs.*;
3	- sealing rubber ring	- 2 pcs.*;
4	- hole placement template	- 1 pc.;
5	- fuse with holder (2 A)	- 2 pcs.;
6	- bottom stop	- 1 pc.;
7	- bolt	- 5 pcs.;
8	- self-tapping screw	- 5 pcs.;
9	- threaded rivet	- 5 pcs.;
10	- sealing cord	- 2 pcs.;
11	- plastic seal	- 2 pcs.**

Figure 59 — MK DUT-E mounting kit

* 1 pc. – used for DUT-E installation and 1 pc. is a spare part.
Could be complemented with 4 mm thick gasket.

** Exterior of seal can be different.

5.2 Connection cables

Table 15 – Connection cables are used for *DUT-E* electrical connection

View	Indication (order code)	Function and description
	Cable 076-01 (sensor cable)	Designed for connection of analog DUT-E to tracking devices and to external power supply. Length – 7.5 m
	Cable 084 (extension for cable 076-01)	To extend the length of 076-01 cable. Length – 3 m
	Cable DUT-E-232/485 (sensor connection cable)	To connect the sensors to recording and display units and to external power supply. Length – 7 m
	RS 2AMP-300 (232/485 cable extender)	To extend the length of cable DUT-E-232/485. Length – 3 m
	RS 2AMP-1000 (232/485 cable extender)	To extend the length of cable DUT-E-232/485. Length – 10 m

5.4 Additional accessories

Table 16 – DUT-E Additional accessories

View	Name	Description	Application
	Filter DUT-E	Screen filter	For protecting electrodes (tubes) against water and mud in tanks' bottom
	FTP DUT-E	Fuel tank plug	Bayonet plug for temporary sensor replacement
	Plug	Plug for sensor mounting hole	To plug fuel tank opening
	Gasket	Rubber gasket 2 mm	Rubber gasket under mounting plate
	DUT-E WP-11	Adaptor plate with 4 holes	To mount the sensor in the tank in the place for the Omnicomm sensor
	SAE 5 bolt	Mounting plate	Mounting plate with SAE 5 bolt standard bore position
	DUT-E FP CT	Mounting plate for barrel-shaped tanks	Mounting plate for sensors installation on barrel-shaped fuel tanks
	DUT-E TAM-d105	Mounting plate	Special duralumin mounting plate for 6 screws
	DUT-E WP-10	Wedge-shaped fastening plate	Fastening plate for sensors installation on fuel tanks with inclined surface (10-degree angle)
	DUT-E WP-12	Mounting plate with a hidden lock pin	Sensor mounting plate with a lock pin, to protect the sensor from theft and vandalism
	DUT-E Bracket	Protective bracket	Bracket to protect the sensor from theft and vandalism

6 Diagnostics and troubleshooting

In case of any malfunction first of all examine condition of [Vehicle](#) power supply system and power supply pins condition of the [DUT-E](#) connector.



WARNING:

- 1) Severe contact corrosion of chassis ground connection switch or its malfunction can seriously affect DUT-E output signal.
- 2) DUT-E readings will be invalid if the measuring tubes are closed by conducting mud or water.

6.1 DUT-E with analog output

Normal operation of analog DUT-E sensors can be verified with a multimeter by measuring their output voltage (for DUT-E AF/A5/A10) or current (for DUT-E I) and comparing the measurement results with the data of table 17.

Table 17 — Analog DUT-E malfunctions

Output signal value	Malfunction reason	Solution
Voltage: from 1 to 9 V (for DUT-E AF) from 0.4 to 5.0 V (for DUT-E A5); from 0.4 to 10.0 V (for DUT-E A10) Current: 2...22 mA (for DUT-E I)	No malfunctions, normal operation	Check tracking device operation
Voltage: from 9.5 to 10 V (for DUT-E AF) over 5 V (for DUT-E A5); over 10 V (for DUT-E A10) Current: Over 22 mA (for DUT-E I)	Short circuit of the measuring probe tubes due to metal shavings and burrs, conductive mud or water at the bottom of the fuel tank	Eliminate short circuit, wash the tubes of the sensor, clean the fuel tank
Voltage: from 0.5 V and less (for DUT-E AF) less than 0.4 V (for DUT-E A5 and DUT-E A10) Current: less than 2 mA (for DUT-E I)	Sensor is not calibrated*	Calibrate the sensor*
	Sensor PCB failure	Contact the closest service center
* Only for DUT-E AF		

Diagnostics of DUT-E AF can be carried out with service adapter the same way as for other DUT-E 232/485 modifications having digital output (see [6.3](#)).

6.2 DUT-E with frequency output

Normal operation of frequency [DUT-E](#) can be verified with frequency meter by measuring output sensor frequency and comparing results of measurements with the data in table 18.

Table 18 — Frequency DUT-E malfunctions

Output frequency, Hz	Malfunction reason	Solution
from 500 to 1500	No malfunctions, normal operation	Check tracking device operation
1600	Short circuit of the measuring probe tubes due to metal shavings and burrs, conductive mud or water at the bottom of the fuel tank	Eliminate short circuit, wash the tubes of the probe, clean the fuel tank
400	Sensor is not calibrated	Calibrate the sensor
	Sensor PCB failure	Contact the closest service center

Diagnostics of DUT-E AF can be carried out with service adapter the same way as for other DUT-E 232/485 modifications having digital output (see [6.3](#)).

6.3 DUT-E with digital output

Normal operation of digital [DUT-E](#) 232/485 sensors is verified with the help of service adapter connection (see [3.10.10](#)).

7 Maintenance

7.1 General instructions

DUT-E visual inspection and operation check is recommended at least once per year.



IMPORTANT: it is recommended to periodically (once per year) check calibration of sensor for minimum and maximum values of fuel level (given the shape of fuel tank was not changed). In case of incorrect values, make calibration once again according to [3.10.3*](#). Repeated calibration of fuel tank of Vehicle in this case is not needed.

DUT-E repair works are carried out only by certified [Regional Service Centers](#) (hereinafter, RSCs). Full RSCs list can be found at <https://www.jv-technoton.com/>.

* Valid only for DUT-E AF/232/485 models.

Repeated calibration of sensor for minimum and maximum values for DUT-E A5/A10/F/I is done only by RSC.

7.2 Demounting

Clean the tank surface nearby the mounting location before [DUT-E](#) demounting.

Prepare a clean napkin to clean the fuel from the sensor probe.

Cut the sealing cord carefully, with no damage to connection cable.

Disconnect DUT-E cable connector.

Unfasten DUT-E by turning its body counterclockwise.

Mount the fuel tank plug (be ordered separately) for protection from any possible clogging through mounting opening.

ATTENTION:



- 1)** To avoid any cable/PCB damage do not pull the interface cable when demounting DUT-E.
- 2)** Screen-filter dismantling should be done carefully to avoid breaking latches of fixator.
- 3)** In case of repeated installation of DUT-E – replace the old rubber gasket with a new one.

7.3 Examination

Since [DUT-E](#) is demounted conduct a visual examination to detect the following defects:

- visible damages of the sensor head body, measuring probe, interface cable, cable;
- backlash of measuring unit tubes relative to each other and/or the body;
- presence of mud or paraffin between the tubes of the measuring probe;
- damage of the plastic mounting plate and traces of fuel leaks through the rubber gasket of the mounting plate.

Contact [RSC](#) (see [7.1](#)) or [Manufacturer](#) if the defects detected.

7.4 Cleaning

During [DUT-E](#) operation mud or paraffin formation is possible on the surface of the measuring probe pipes. Pollution of the cavity between the pipes of the measuring probe can lead to significant increase of accuracy error.



ATTENTION: Mud coating inside the inner measuring tube does not affect DUT-E normal operation. Examine the space between the tubes for mud and paraffin.

To clean the tubes wash them with the clean fuel. If there is paraffin in the cavity between the tubes, it is necessary to slightly warm the measuring part with a heat gun to remove it. It is also recommended to wash the [screen filter](#) as well.



ATTENTION: Avoid fuel getting on DUT-E head body, interface cable and its connector when washing the tubes.

8 Packaging

[DUT-E](#) and [SK DUT-E](#) delivery sets come in cardboard boxes of the following shape (see figure 60)



Figure 60 — Packaging

Label sticker with information on the product name, certificates, serial number, firmware version, manufacture date, certificates, weight as well as Quality Control seal and QR code is stuck on two sides of the DUT-E box (see figure 61 a).

Label sticker with information on the product name, serial number, software [Service DUT-E](#) version, manufacture date, weight and Quality Control seal and QR code is stuck on two sides of the SK DUT-E box. (see figure 61 b).



Figure 61 — Packaging label

Note — label design and contents can be modified by the [Manufacturer](#).

9 Storage

[DUT-E](#) is recommended to be stored in dry enclosed areas.

DUT-E storage is allowed only in original packaging at temperature range from -50 to +40° C and relative humidity up to 100 % at +25° C.

Do not store DUT-E in the same room with substances that cause metal corrosion and/or contain aggressive impurities.

DUT-E shelf life must not exceed 24 months.

10 Transportation

Transportation of [DUT-E](#) is recommended in closed transport that provides protection for DUT-E from mechanical damage and precipitation.

When transporting by air, DUT-E must be stored in heated pressurized compartments.

Air environment in transportation compartments should not contain acid, alkaline and other aggressive impurities.

Shipping containers with packed DUT-E sensors should be sealed.

11 Utilization/re-cycling

[DUT-E](#) does not contain harmful substances and ingredients that are dangerous to human health and environment during and after the end of life and recycling.

DUT-E does not contain precious metals in amount that should be recorded.

Contacts

Distribution, technical support and service



sales@jv-technoton.com

support@jv-technoton.com



Annex A

Template of check test report

Report

Date: _____

DUT-E model and serial number	
Vehicle type, model, registration number	
Tracking/displaying device model and serial number	

Drainage volume	According to calibrated container V_M , liters	
	According to tracking device V_{track} , liters	
Accuracy error	Absolute error $\Delta = V_{\text{track}} - V_M$, liters	
	Normalized to total tank volume $\delta = \frac{V_{\text{track}} - V_M}{V_{\text{total_volume}}} \cdot 100\%$	

Refueling volume	According to calibrated container V_M , liters	
	According to tracking device V_{track} , liters	
Accuracy error	Absolute error $\Delta = V_{\text{track}} - V_M$, liters	
	Normalized to total tank volume $\delta = \frac{V_{\text{track}} - V_M}{V_{\text{total_volume}}} \cdot 100\%$	

Resume:

The results of measurement **match/do not match** specifications.

The results of refueling measurement **match/do not match** specifications.

Comments: _____

representative of the CUSTOMER: _____ / _____

representative of the CONTRACTOR: _____ / _____

Annex B

Method of recording the calibration table for tanks of great capacity

For calibration of tanks (fixed tanks) of 6553.5 l capacity and higher, you need to change digit capacity of fuel volume values in all points of the calibration (column **Volume, l**).

The actual position of the decimal divider of the whole and fractional parts is ignored in volume values.

The discreteness of volume measurement in calibration points is changed from 0.1 liter to 1.0 liter.

The maximum possible volume value in the calibration table — 6553.5 l.

After the transfer of fuel volume data to the [Server](#) or to the tracking device, you don't have to multiply the value by 0.1 coefficient.



WARNING: For calibration of a tank (fixed tank) of greater than 6553.5 l capacity, you need to send fuel level values to the Server **in millimeters**. It is sufficient to create the calibration table only at the Server. No need to record the calibration table into the sensor memory.

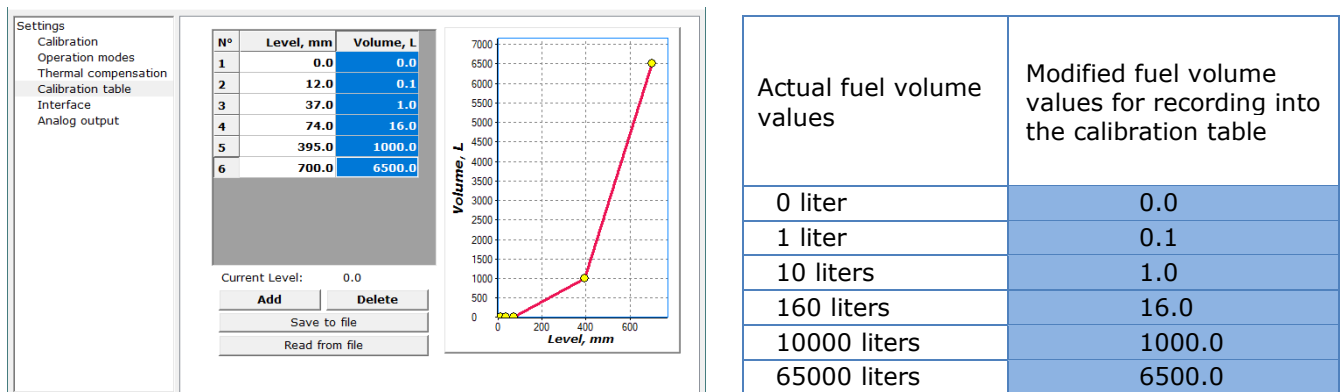

Figure B.1 — Example of recording of fuel volume values with changed discreteness into the calibration table with the help of Service DUT-E software

Annex C

DUT-E profile printed copy

Fuel level sensor

Passport

Model sensor	DUT-E AF
Serial number	092001302783
Firmware version	3.12
Date compil	Jan 09 2016
Time compil	09:15:05

Settings

Calibration

Actual length of sensor after trimming (mm)	685.0
---	-------

Thermal compensation

Thermal compensation (-3...3 %/°C)	0
------------------------------------	---

Operation mode

Fuel level filter time, 0..120 s step=10 s	0
Address (101..108)	101

Analog output

Level min. (1.0...8.0 V):	1.000
Level max. (2.0...9.0 V):	9.000
Output signal type:	U
Output signal type:	Level
Diagnostics:	off

Calibration table

No	Level, mm	Volume, l
001	0.0	0.0
002	63.9	10.0
003	130.4	20.0
004	215.0	30.0
005	300.0	40.0
006	408.6	50.0
007	510.5	60.0
008	603.7	70.0
009	685.0	80.0

Parameters of sensor calibration

Frequency of calibration "free", Hz	2309.99
Frequency of calibration "free", Hz	1200.94

Annex D

DUT-E log file example

Filename: DUT_SN 092001302783 _D15.04.2015_T145012.txt

File contents:

```

1 14:50:12 23.0 2306.14 2308.67 1 0.4 0.4 0.4 0.1 0.0
2 14:50:13 23.0 2305.98 2308.51 1 0.5 0.5 0.5 0.1 0.0
3 14:50:14 23.0 2306.00 2308.53 1 0.5 0.5 0.5 0.1 0.0
4 14:50:16 23.0 2305.83 2308.36 1 0.5 0.5 0.5 0.1 0.0
5 14:50:17 23.0 2306.16 2308.69 1 0.4 0.4 0.4 0.1 0.0
6 14:50:18 23.0 2305.96 2308.49 1 0.5 0.5 0.5 0.1 0.0
7 14:50:19 23.0 2305.99 2308.52 1 0.5 0.5 0.5 0.1 0.0
8 14:50:20 23.0 2306.08 2308.61 1 0.4 0.4 0.4 0.1 0.0
9 14:50:21 23.0 2305.87 2308.40 1 0.5 0.5 0.5 0.1 0.0
10 14:50:22 23.0 2306.07 2308.60 1 0.4 0.4 0.4 0.1 0.0
11 14:50:24 23.0 2306.11 2308.64 1 0.4 0.4 0.4 0.1 0.0
12 14:50:25 23.0 2306.05 2308.58 1 0.5 0.5 0.5 0.1 0.0
13 14:50:26 23.0 2305.99 2308.52 1 0.5 0.5 0.5 0.1 0.0
14 14:50:27 23.0 2305.90 2308.43 1 0.5 0.5 0.5 0.1 0.0
15 14:50:28 23.0 2305.92 2308.45 1 0.5 0.5 0.5 0.1 0.0
16 14:50:29 23.0 2305.91 2308.44 1 0.5 0.5 0.5 0.1 0.0
17 14:50:30 23.0 2305.97 2308.50 1 0.5 0.5 0.5 0.1 0.0
18 14:50:31 23.0 2306.16 2308.69 1 0.4 0.4 0.4 0.1 0.0
19 14:50:33 23.0 2305.98 2308.51 1 0.5 0.5 0.5 0.1 0.0
20 14:50:34 23.0 2305.84 2308.37 1 0.5 0.5 0.5 0.1 0.0
21 14:50:35 23.0 2306.00 2308.53 1 0.5 0.5 0.5 0.1 0.0
22 14:50:36 23.0 2306.01 2308.54 1 0.5 0.5 0.5 0.1 0.0
23 14:50:37 23.0 2305.89 2308.42 1 0.5 0.5 0.5 0.1 0.0
24 14:50:39 23.0 2306.17 2308.70 1 0.4 0.4 0.4 0.1 0.0
25 14:50:40 23.0 2305.84 2308.37 1 0.5 0.5 0.5 0.1 0.0
26 14:50:41 23.0 2306.24 2308.77 1 0.4 0.4 0.4 0.1 0.0
27 14:50:42 23.0 2306.02 2308.55 1 0.5 0.5 0.5 0.1 0.0
28 14:50:43 23.0 2305.82 2308.35 1 0.5 0.5 0.5 0.1 0.0
29 14:50:44 23.0 2306.05 2308.58 1 0.5 0.5 0.5 0.1 0.0
30 14:50:45 23.0 2305.81 2308.34 1 0.5 0.5 0.5 0.1 0.0
31 14:50:46 23.0 2305.88 2308.41 1 0.5 0.5 0.5 0.1 0.0
32 14:50:48 23.0 2305.95 2308.48 1 0.5 0.5 0.5 0.1 0.0
33 14:50:49 23.0 2305.93 2308.46 1 0.5 0.5 0.5 0.1 0.0
34 14:50:50 23.0 2306.05 2308.58 1 0.5 0.5 0.5 0.1 0.0
35 14:50:51 23.0 2306.01 2308.54 1 0.5 0.5 0.5 0.1 0.0
36 14:50:52 23.0 2306.03 2308.56 1 0.5 0.5 0.5 0.1 0.0
37 14:50:53 23.0 2305.98 2308.51 1 0.5 0.5 0.5 0.1 0.0
38 14:50:55 23.0 2306.04 2308.57 1 0.5 0.5 0.5 0.1 0.0
39 14:50:56 23.0 2306.07 2308.60 1 0.4 0.4 0.4 0.1 0.0

```

1 2 3 4 5 6 7 8 9 10 11 ← Data field numbers

Data fields description:

- 1** — check point number;
- 2** — current time;
- 3** — ambient temperature (C°);
- 4** — initial measuring generator frequency (Hz);
- 5** — temperature compensated measuring generator frequency (Hz);
- 6** — fuel level (s.u.);
- 7** — initial fuel level (mm);
- 8** — temperature compensated fuel level (mm);
- 9** — temperature compensated filtered fuel level (mm);
- 10** — fuel volume (l);
- 11** — fuel volume (%).

Annex E

Electromagnetic compatibility specifications of DUT-E

Table E.1 — Protection of power circuits of DUT-E against conductive, capacitive and inductive interference as described in ISO 7637-2:2002

Test pulse	Test level	U _s tested level, V for supply voltage	
		12 V	24 V
1	IV	-100	-600
2a	IV	+50	+50
2b	IV	+10	+20
3a	IV	-150	-200
3b	IV	+100	+200
4	IV	-7	-16
5	III	+65	+123

Table E.2 — Protection of signal circuits of DUT-E against conductive, capacitive and inductive interference as described in ISO 7637-3:2002

Test pulse	Test level	U _s tested level, V for supply voltage	
		12 V	24 V
Pulse "a" of short duration	IV	-60	-80
Pulse "b" of short duration	IV	+40	+80
Positive pulse of long duration (DCC)	IV	+30	+45
Negative pulse of long duration (DCC)	IV	-30	-45
Positive pulse of long duration (ICC)	IV	+6	+10
Negative pulse of long duration (ICC)	IV	-6	-10

Table E.3— DUT-E own radio interference field strength as per UNECE Regulation No.10 (Revision 4)

Tested bandwidth, Mhz	Quasi-peak value of field strength of radio interference, dB μ V/m		Average value of field strength of radio interference, dB μ V/m	
	Horizontal polarization	Vertical polarization	Horizontal polarization	Vertical polarization
30...34	27	25	20	20
34...45	23	21	16	18
45...60	18	18	13	14
60...75	17	16	10	9
75...100	11	13	7	8
100...130	12	14	7	9
130...170	22	16	18	12
170...225	24	18	18	13
225...300	32	24	27	11
300...400	19	21	13	14
400...525	22	24	16	15
525...700	24	27	23	23
700...850	34	32	25	27
850...1000	35	33	27	26

Annex F

ASCII text data transfer protocol for DUT-E 232/485

ASCII text protocol (American Standard Code for Information Interchange) is used for automatic data transfer by [DUT-E 232/485](#) digital fuel level sensors, according to TIA/EIA 232-F and ANSI/TIA-485-A standards.

The data transfer interval is set within the range 1...255 s (1 s by default) using Service DUT-E software (see figure F.1).

ASCII text protocol is a code for interpretation of decimal digits, Latin and national alphabets, punctuation characters and command characters. The protocol allows to convert numerical values (names) needing description into simple letter characters.

1) According to ASCII text protocol, DUT-E 232/485 sensor transfers the following three parameters in the form of characters (ASCII code) at set intervals (see figure F.2):

F – value of the current of the sensor measuring generator frequency, Hz;

t – value of the sensor temperature, °C;

N – current sensor readings in units preset using the service software (conventional units/mm/liters/%) (see figure F.1).

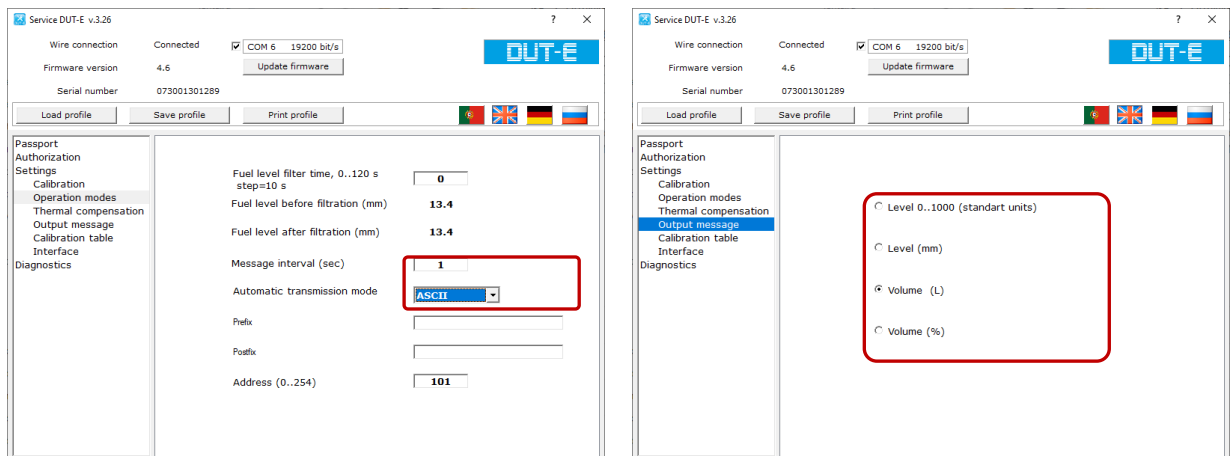

Figure F.1 — Example of DUT-E 232 sensor settings made using the service software for data transfer, according to ASCII text protocol



Figure F.2 — Example of display of parameters transferred by DUT-E 232 with the set period of data transfer, according to ASCII text protocol, in the software that registers data of COM-port

2) According to ASCII EXT extended text protocol, DUT-E 232/485 sensor displays one parameter at set intervals in the form of characters (ASCII code) — current data readings in units preset using the service software (conventional units/mm/liters/%) (see figure F.3).

The parameter value is placed between two special words specified by the user, up to 21 characters long (e.g. **Prefix [** and **]Postfix**) which indicate, respectively, the beginning and the end of the line containing the parameter which is transferred (see figure F.4).

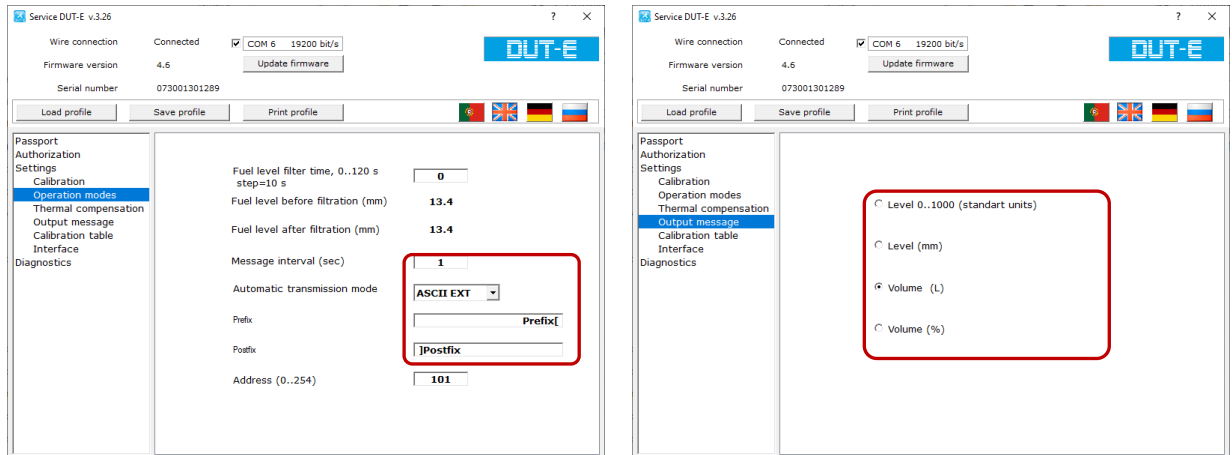

Figure F.3 — Example of DUT-E 232 sensor settings made using the service software for data transfer, according to ASCII EXT extended text protocol

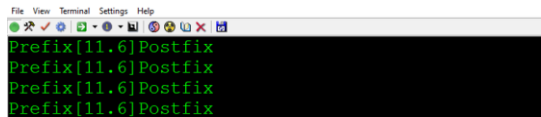

Figure F.4 — Example of display of the parameter transferred by DUT-E 232 with the set period of data transfer, according to ASCII EXT extended text protocol, in the software that registers data of COM-port

Annex G Videography

1) Video clip DUT-E ATS-1 automatic tank calibration station.

Check out the link:  <https://youtu.be/uFF1mG-iz6A>

2) Animation Wireless fuel level sensor DUT-E S7.

Check out the link:  https://youtu.be/MnbGXn9JX_g

3) Animation DUT-E 2Bio fuel level sensor.

Check out the link:  <https://www.youtube.com/watch?v=WR1556gaN7o>

4) Animation DUT-E GSM fuel level sensor.

Check out the link:  <https://www.youtube.com/watch?v=ixBaKMzKtG8>

5) Video clip DUT-E 485 fuel level sensor installation.

Check out the link:  <https://www.youtube.com/watch?v=X0gUSF3dRWk>

6) Video clip Length extension of measurement part DUT-E Using measuring sections KDC

Check out the link:  https://www.youtube.com/watch?v=dWuY_JJfhFw

7) Video clip Filter Screen of DUT-E fuel level sensor

Check out the link:  <https://www.youtube.com/watch?v=B5dcYxGfSqQ>

8) Other [Technoton](#) videos are on the YouTube channel which is regularly updated:

 <https://www.youtube.com/channel/UCq7EF3DHrgl7fOWB2ynsR-A>