

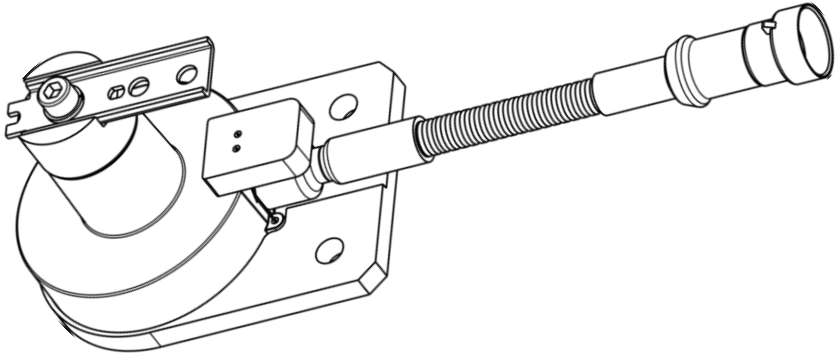

AXLE LOAD SENSORS

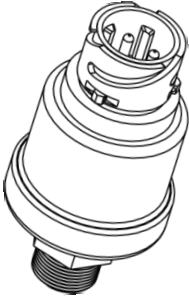

GNOM DP A



GNOM DDE

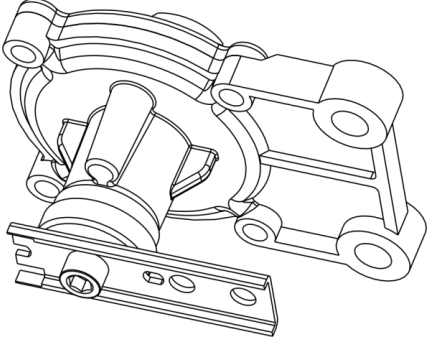

GNOM DP / GNOM DP CAN

OPERATION MANUAL

Version 5.1



TECHNOTON
ADVANCED MACHINERY TELEMATICS

Contents

Contents	2
Revision history	4
Structure of external links	5
Terms and Definitions	6
Introduction	8
1 General information and technical specifications	10
1.1 Purpose of use and application area	10
1.2 Exterior view and delivery set	15
1.3 Structure and operation principle	17
1.4 Technical specifications	19
1.4.1 Main specifications	19
1.4.2 Characteristics of GNOM DP A / GNOM DP / GNOM DDE output analog signals	20
1.4.3 Characteristics of GNOM DP CAN digital signal	22
1.4.4 Sensors and tracking devices compatibility	24
1.4.5 Overall dimensions	25
2 Mounting	27
2.1 Exterior inspection prior to works start	27
2.2 Vehicle status evaluation	28
2.3 GNOM DP mounting	29
2.3.1 General instructions	29
2.3.2 Selection of mounting location and procedure for the sensor mounting	30
2.3.3 Stages of mounting the sensor according to the typical scheme for a two-axial Vehicle	33
2.3.4 Stages of mounting the sensor according to the typical scheme for a three-axial Vehicle	35
2.4 GNOM DDE mounting	37
2.4.1 General instructions	37
2.4.2 Selecting mounting location and scheme	38
2.4.3 Rules for installation works	41
2.5 Electrical connection	42
2.6 Sealing	46
2.7 Calibration	47
2.8 GNOM accuracy check	49
2.8.1 Purpose of the test	49
2.8.2 Test preparation	50
2.8.3 Testing	51
2.9 Accessories	52
2.9.1 Mounting kit GNOM MK DP universal	52
2.9.2 Mounting kit GNOM MK DP 1-axle	53
2.9.3 Mounting kit GNOM MK DDE2	54
2.9.4 Signal cables	55
2.9.5 Optional accessories	56

3 Axle load monitor	57
4 Packaging	64
5 Storage	65
6 Transportation.....	66
7 Utilization/re-cycling	67
Contacts.....	68
Annex A Template of check test report.....	69
Annex B Cargo weight monitoring.....	70
Annex C Diagrams of pre-set information screens for axle load monitor.....	72
Annex D Recommendations on the equipment calibration, connection and configuration, when using GNOM sensors.....	74
Annex E Videography	79

Revision history

Version	Date	Editor	Description of changes
1.0	07.2013	OD	Basic version.
2.0	02.2015	OD	BSKD T-60 axle load monitor description is added.
3.0	04.2019	OD	<ul style="list-style-type: none"> • Examples of using GNOM sensors in axle load monitoring systems in different types of road trains are added. • Significant additions and clarifications are made in the description of GNOM sensors mounting procedure. • Recommendations on the equipment calibration, connection and configuration when using GNOM sensors are added. • A brief description of MasterCAN Display 35 G employment as axle load monitor is introduced. (A description of BSKD T-60 axle load monitor is deleted because it is no longer produced). • Changes in the delivery set of GNOM MK DP mounting kit. • A structure of the document external links is created.
4.0	10.2020	OD	<p>Additions:</p> <ul style="list-style-type: none"> • Description of GNOM DP CAN digital position sensor. • Description of GNOM MK DP 1-axle mounting kit for two-axial Vehicles with leaf-spring suspension. • Additional accessories for axles load sensors.
5.0	01.2024	OD	<ul style="list-style-type: none"> • A new model of analog position sensor — GNOM DP A (08001) is introduced. • Information on the product is added. • The sensors technical specifications are updated. • Corrected electrical connection of GNOM DP CAN. • Examples of the sensors connection diagrams to CAN-display of MasterCAN Display 35 and Units are updated etc.
5.1	11.2025	OD	<ul style="list-style-type: none"> • The enclosure protection rating for GNOM DP A sensors has been increased to IP65/67 (IEC 60529:2013).

Structure of external links

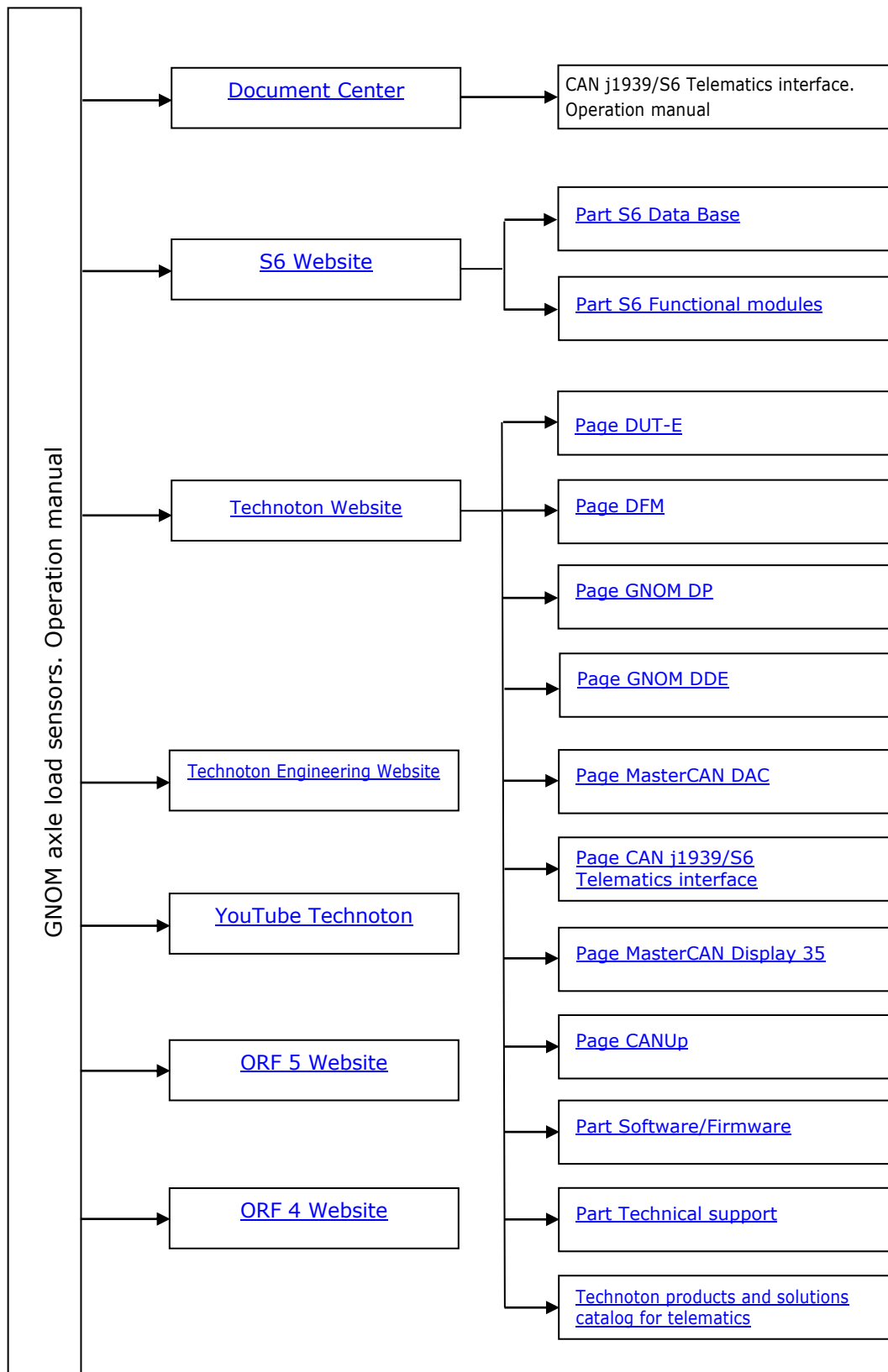

Terms and Definitions

S6 is the Technology of combining smart sensors and other IoT devices within one wire network for monitoring of complex stationary and mobile objects: Vehicles, locomotives, smart homes, technological equipment etc. The Technology is based and expands SAE j1939 automotive standards.



Information on cabling system, service adapter and S6 software refer to [CAN j1939/S6 Operation manual](#).

ORF 4 / ORF 5 — is the Telematics service by Technoton developed for receiving and processing Onboard reports via Internet, displaying Operational data overlapped on area maps, information storage in database and Analytical reports generation upon user's request.

PGN (Parameter Group Number) — is a combined group of S6 parameters, which has common name and number. Functional modules (FM) of the Unit can have input/output PGNs and setup PGNs.

SPN (Suspect Parameter Number) — informational unit of S6. Each SPN has determined name, number, extension, data type and numerical value. The following types of SPN exist: Parameters, Counters, Events. SPN can have a qualifier which allows qualification of parameter's value (e.g. – Onboard power supply limit/Minimum).

Analytical report — report generated in [ORF 4](#) / [ORF 5](#) on Vehicle or group of Vehicles operation for chosen time period (usually a day, week or month). Can be composed of numbers, tables, charts, mapped route of Vehicle, diagrams.

Event — relatively rare and sudden change in SPN. Sharp increase in axle load is "Load" Event. This Event may have one or more characteristics. So, the "Load" Event has the following characteristics: date/time, "axle load at the beginning of loading", "axle load at the end of loading", "cargo weight" etc. When the Event occurs, a terminal unit registers the time of occurrence, which is later mentioned in a report on the Event. Thus, the Event is always attached to exact time and place of occurrence.

Function module (FM) unit-embedded component of hardware and software combination, executing a group of special functions. Uses input/output PGNs and settings PGNs.

GNSS (Global Navigation Satellite System) — System for area positioning of an object through satellite signal processing. GNSS is composed of space, ground and user segments. Currently, there are several GNSSs: GPS, GLONASS, Galileo, BeiDou.

Onboard equipment (OE) — Telematics system elements, directly installed in Vehicle.

Onboard reports (the Reports) — information about Vehicle which is returned to a user of Telematics system in accordance with inputted criteria. The Reports are generated by a terminal unit both periodically (Periodic reports) and on Event occurrence (Event report).

Parameter — time-varying or space characteristic of the Vehicle (SPN value). For example, speed, fuel volume in the tank, hourly fuel consumption, axle load, coordinates. Parameter is usually displayed in the form of graph, or averaged data.

Server (AVL Server) — hardware-software complex of Telematics service ORF 4, used for processing and storage of Operational data, formation and transmission of Analytical reports through Internet by request of ORF 4 / ORF 5 users.

Telematics terminal (Tracking device, Telematics unit) is a unit of Telematics system used for reading the signals of Vehicle standard and additional sensors, getting location data and transmitting the data to the Server.

Telematics system — complex solution for Vehicle monitoring in real time and trip analysis. The main monitored characteristics of the Vehicle: Route, Fuel consumption, Working time, technical integrity, Safety. It includes On-board report, Communication channels, Telematics service [ORF 4](#) / [ORF 5](#).

Vehicle an object controlled within Telematics system. Usually Vehicle means a truck, tractor or bus, sometimes a locomotive or river boat. From Telematics system point of view, stationary objects are also considered to be Vehicles: diesel gensets, stationary tanks, boilers/burners.

Unit is an element of Vehicle on-board equipment compatible with S6 bus, which uses [S6 Technology](#).

Introduction

The Operation Manual contains guidelines and rules which refer to **GNOM axle load sensors** (hereinafter [GNOM](#)).

This document contains information on design, operation principle, specifications of GNOM sensors, recommendations on their installation and use.

GNOM additional Vehicle sensors for monitoring axles load and the [Vehicle load weight in transport Telematics systems](#).

GNOM features:

- mounting on any Vehicles equipped with leaf spring¹ suspension or air² suspension;
- magnetoresistive¹ or tensoresistive² principle of measurement;
- high degree of protection from external impact;
- linear output characteristic of the output signal simplifies data processing by the monitoring system;
- output signal is stabilized and does not depend on the onboard circuit voltage;
- short-circuit and reverse polarity protection;
- increased wear resistance due to absence of friction elements;
- compliance with [Units](#), [Database](#) and cabling system [S6 Technology](#)³;
- function of digital self-diagnostics for sensor quality control³;
- well-organized [mounting kits](#) are available;
- high-quality [technical support](#) and [documentation](#);
- compliance with national and European automobile standards of electromagnetic compatibility, endurance towards climatic and mechanical impact.

GNOM sensors are presented with the following models:

- 1) **GNOM DP A** / **GNOM DP** — analog position sensor for axles load monitoring systems for Vehicles equipped with leaf-spring suspension.
- 2) **GNOM DP CAN** — digital position sensor (CAN 2.0B interface (SAE j1939)) for axles load monitoring systems of Vehicles equipped with leaf-spring suspension.
- 3) **GNOM DDE** — Analog pressure sensor for axles load monitoring systems of Vehicles equipped with air suspension.

¹ Valid for the position sensors GNOM DP A / GNOM DP / GNOM DP CAN.

² Valid for GNOM DDE pressure sensors.

³ Valid for GNOM DP CAN digital sensor.

GNOM DP A position sensor complies with model type **08001** identified by the first five digits of its serial number printed on the sensor casing or on the packing label (see figure 1).

Note — Model type is the digital code reflecting GNOM DP A design. For GNOM DDE / GNOM DP / GNOM DP CAN, model type is not foreseen.



Figure 1 — Identifying GNOM DP A model type

For ordering GNOM sensors, their designation is specified according to figure 2.

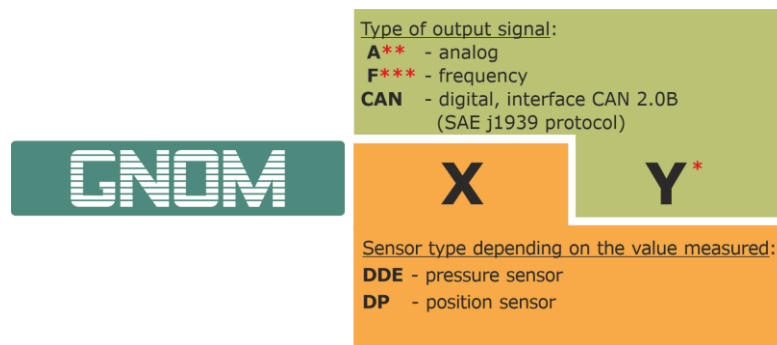

- * Y designation is not used for a pressure sensor.
- ** Letter A is specified only for the position sensor which corresponds to model type 08001.
- *** In preparation for introduction.

Figure 2 — Designation of GNOM sensors for placing an order

Examples of GNOM sensors specification, when placing an order:

- "GNOM DP A position sensor" or "GNOM DP A (08001) position sensor".
- "GNOM DP CAN position sensor".
- "GNOM DP position sensor".
- "GNOM DDE pressure sensor".



ATTENTION: It is strongly recommended to follow strictly the instructions of the present Manual when using, mounting or maintaining GNOM.

The Manufacturer guarantees GNOM compliance with the requirements of technical regulations subject to the conditions of storage, transportation and operation set out in this Manual.



ATTENTION: Manufacturer reserves the right to modify GNOM specifications that do not lead to a deterioration of the consumer qualities without prior customer notice.

1 General information and technical specifications

1.1 Purpose of use and application area

GNOM DP A / **GNOM DP** / **GNOM DP CAN** position sensors are designed to measure axle load and cargo weight on [Vehicles](#) with leaf spring suspension.

GNOM DDE pressure sensor is designed to measure axle load and cargo weight on [Vehicles](#) with air suspension.

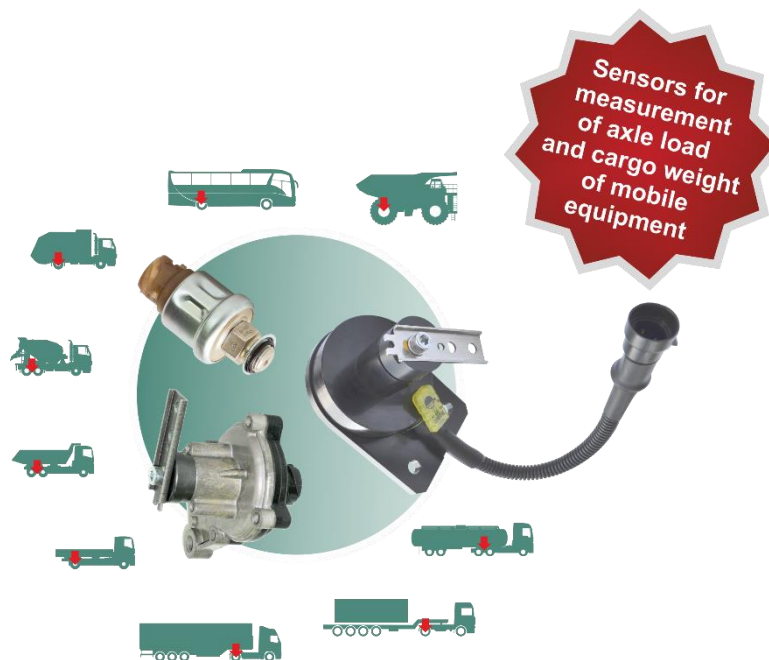

Figure 3 — Purpose of GNOM sensors

Application areas: GNOM axle load sensors can be applied as part of [Telematics systems](#):

1) For monitoring the axle load of a truck (see figure 4).

Depending on a particular model, GNOM sensors are applied using the following methods:

- [GNOM DP A](#) / [GNOM DP](#) / [GNOM DP CAN](#) is fixed to the Vehicle frame (chassis) and is connected to the rear axle with the set of leverages. Sensor measures the distance between the frame and the axle which depends on the weight of the load.
- [GNOM DDE](#) is installed in the Vehicle air suspension circuit. Sensor measures the pressure of compressed air in suspension circuit of the Vehicle. Pressure depends on the weight of the load.

Sensors transmit measured values to the [Tracking device](#) by generating analog voltage output signal. Tracker records and processes the sensor data for further transmission to the telematics server. [Server](#) software processes and analyzes the received data to generate [Analytical reports](#) for a selected period of time. The user gets the report containing figures, counters, charts on Vehicle axle load.

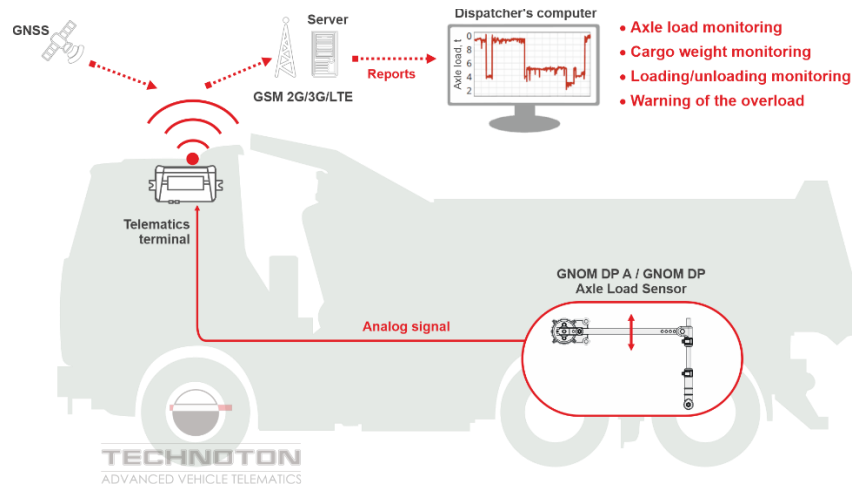

Figure 4 — Example of GNOM DP A / GNOM DP sensor application for monitoring axles load of a truck

2) To monitor axles load of a road train with a non-interchangeable semitrailer (see figure 5).

[GNOM DP A](#) / GNOM DP / GNOM DP CAN position sensor is mounted on a semitrailer frame and is fixed to the rear axle (bogie) with a system of leverages. The sensor measures the distance from the frame to the axle (bogie) varying depending on the cargo weight.

[GNOM DDE](#) pressure sensor is mounted on the rear axle of a truck. The sensor measures pressure of the compressed air in the [Vehicle](#) air suspension circuit varying depending on the cargo weight.

Recommendations regarding the equipment connection and configuration see in [annex D](#).

GNOM sensors transmit output signals to the analog input of [MasterCAN Display 35](#) of CAN j1939/S6 bus. It converts them into digital data (SPN)* and transmits them to [CANUp 27 Standard](#) online Telematics gateway by means of [S6 Technology](#). Besides visual display of axles load values, MasterCAN Display 35 serves to store calibration tables in its non-volatile memory. These tables ensure correct operation of connected GNOM sensors. CANUp 27 Standard collects, records, stores, processes signals received and transmits them to the [Telematics server](#), which generates [Analytical reports](#) for the selected period of time.

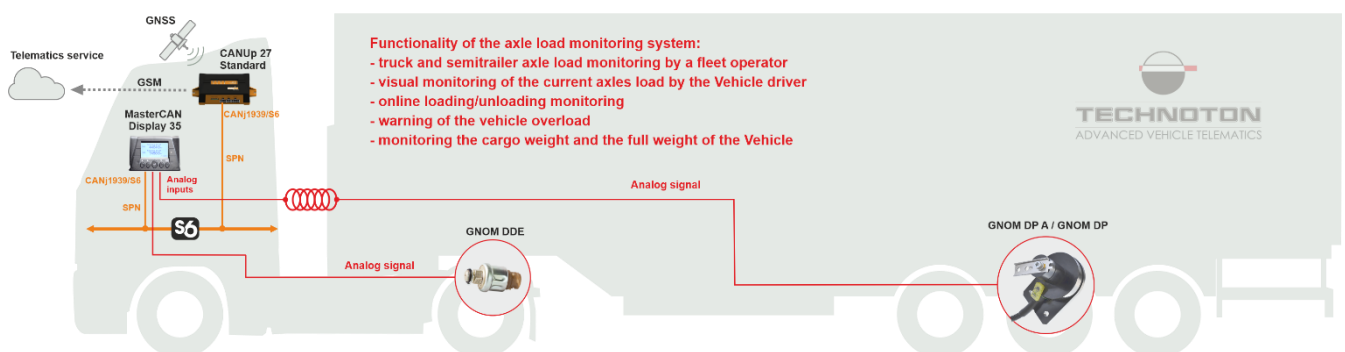

Figure 5 — Example of GNOM sensors application to monitor load on axles of the truck with a non-interchangeable semitrailer

* GNOM DP CAN sensor generates SPN independently and transfers it by means of S6 Technology.

3) To monitor the axles load of a road train with a replaceable semitrailer (see figure 6).

GNOM sensors are mounted on a road train similar to mounting on a non-interchangeable semitrailer. Recommendations on the equipment connection and configuration see in [annex D](#).

[GNOM DP](#) transmits the output signal to the analog input of [MasterCAN DAC 15](#) j1939 digital to analog converter (i/o module) which converts it into digital data (SPN)* of [CAN j1939/S6 Telematics interface](#). During this process MasterCAN DAC 15 saves in its memory the calibration table that defines the correlation of GNOM DP output voltage with different values of loads on the semitrailer axle. This allows to use this semitrailer with another truck with similar mounted equipment.

[GNOM DDE](#) transmits the output signal to the analog input of [CANUp 27 Standard](#) online Telematics gateway which converts the sensor analog signal into digital data (SPN) and saves in its memory the calibration table that defines the correlation of GNOM DDE output voltage with values of loads on the semitrailer axle.

CANUp 27 Standard collects, records, stores, processes data received and transmits them to the [Telematics server](#), which generates [Analytical reports](#) for the selected period of time.

[MasterCAN Display 35](#) of CAN j1939/S6 bus receiving output signals from GNOM sensors converted into SPN using [S6 Technology](#) is employed for visual monitoring values of axle loads by the Vehicle driver.

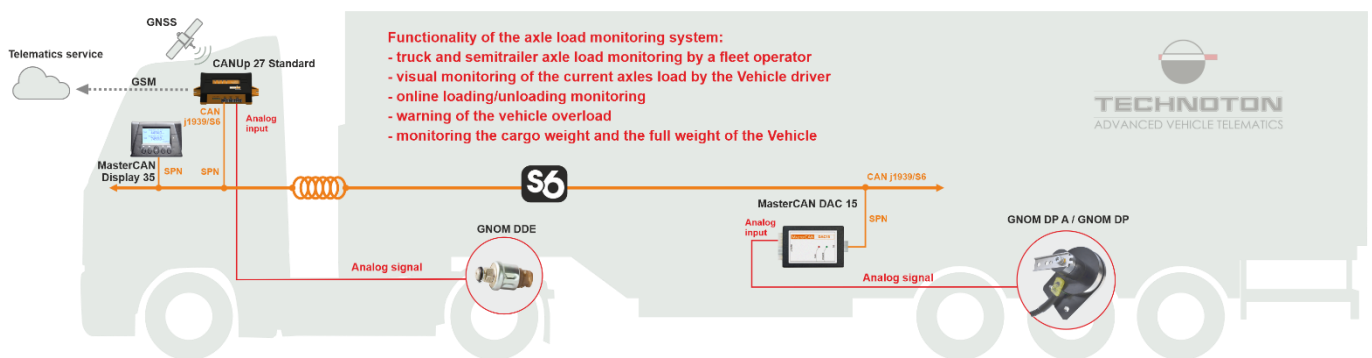

Figure 6 – Example of GNOM sensors application for monitoring axle load of a truck with a replaceable semitrailer

4) To monitor axle load during comprehensive monitoring of a specialized road train using S6 Technology (see figure 7).

GNOM DP and GNOM DDE sensors are mounted on a specialized road train (e.g. refrigerator truck) similar to the options designed for the truck that are described above.

Output signals from GNOM sensors and from standard sensors of the refrigerator van are sent to analog inputs of [MasterCAN DAC 2113](#) j1939 digital to analog converter (i/o module) which converts them into digital data (SPN) and transmits them to [CAN j1939/S6 Telematics interface](#). Besides, MasterCAN DAC 2113 saves in its memory all calibration tables created for correct operation of analog sensors connected to it.

* GNOM DP CAN sensor generates SPN independently and transfers it into CAN j1939/S6 Telematics interface without using MasterCAN DAC digital to analog converter.

We recommend to use [CANUp 27](#) online telematics gateway with extended functionality as [Telematics terminal](#) (models CANUp 27 Pro). The availability of CAN j1939/S6 interface enables CANUp 27 Pro to receive data from [Units](#) by means of [S6 Technology](#) — up to 16 [DUT-E CAN](#) fuel level sensors and up to 16 [DFM CAN](#) fuel flow meters, besides converted signals from GNOM and signals from standard analog sensors. In the given example, DUT-E CAN sensor is mounted in each of the two tanks of the refrigerator truck. [DFM D CAN](#) differential flow meter is mounted in the engine fuel system of the truck engine, while DFM CAN single-chamber flow meter is mounted in the supply line of the engine of the refrigerator truck cooling unit.

CANUp 27 Pro also receives relevant Telematics and diagnostics data from the standard Vehicle CAN bus sorting out all unnecessary data.

If needed, Onboard reports on Events may be automatically sent to the user directly by e-mail (up to 3 e-mail addresses) or in the form of SMS messages (up to 3 telephone numbers) without using the [Server](#) and payment for its services.

For visual monitoring of the fuel, axle load and other refrigerator truck performance parameters by the Vehicle driver [MasterCAN Display 35](#) display of CAN j1939/S6 bus is used.

It receives data from Units, from the Vehicle CAN bus and converted signals from analog sensors using S6 Technology.

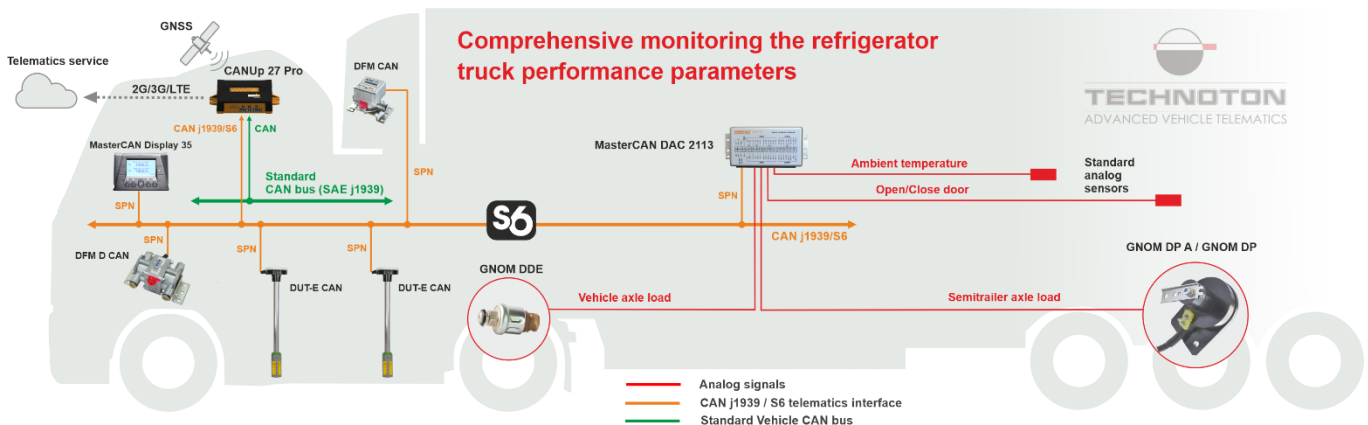
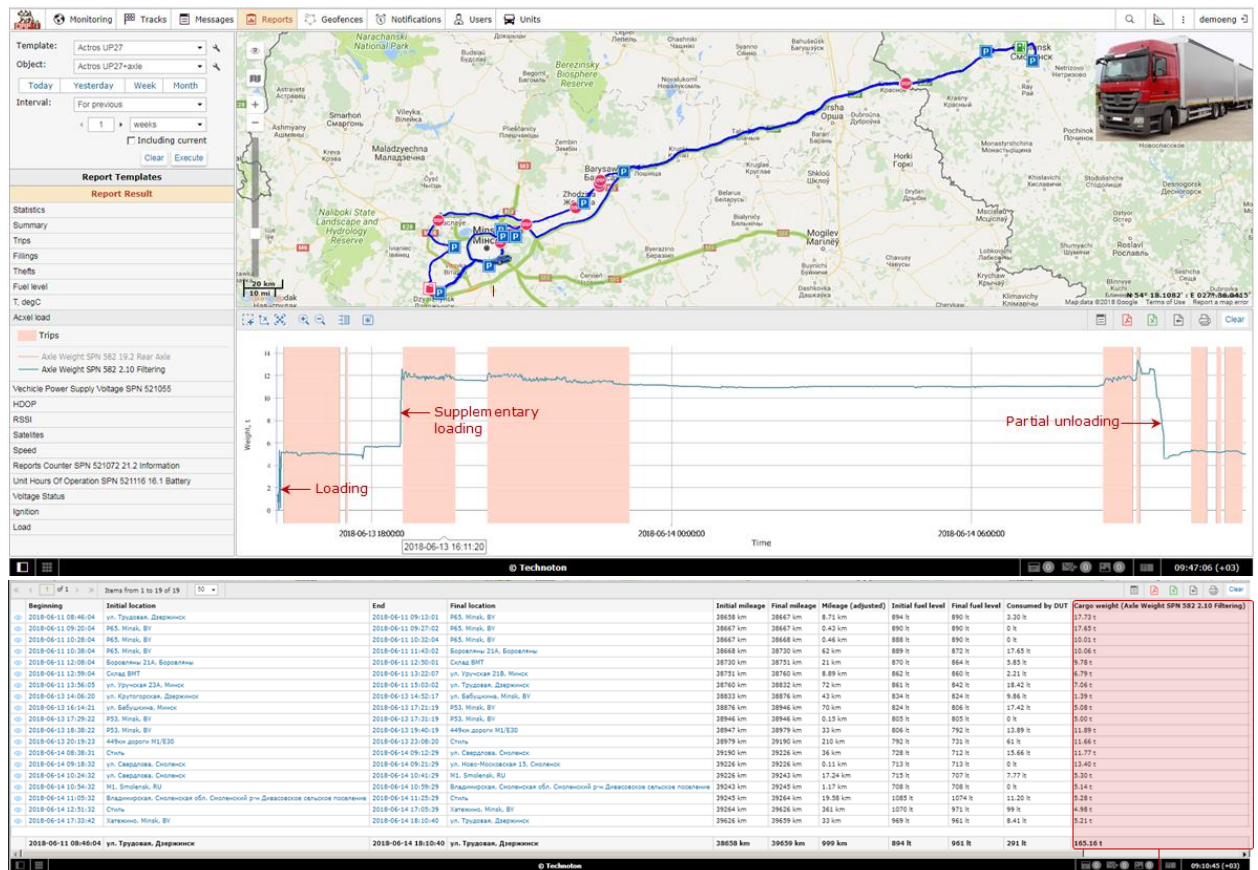

Figure 7 — Example of GNOM sensors application for monitoring axle load at comprehensive monitoring the refrigerator truck performance parameters via S6 Technology



RECOMMENDATION: [ORF 4](#) / [ORF 5](#) Telematics service provides the highest degree of precision and information content during monitoring the route of movement, fuel consumption, axles load and [Vehicle](#) performance parameters (see figure 8).



Axle load of vehicle in each trip within selected time interval of 1 week

Figure 8 – Example of Analytic report created by ORF 4 based on CANUp 27 Pro Onboard reports and the output signal of GNOM sensor

Application of [GNOM](#) sensors within the transport [Telematics system](#) enables the Vehicle owner to conveniently analyze the process of cargo transportation and solves the issues of:

- **Control of drivers, elimination of under-hand cargo transportation.** The sensors inform the fleet owner of unauthorized loading / unloading and under-hand cargo.
- **Optimal vehicles loading.** The sensors provide signals of the vehicle overload and underload. This reduces the wear of vehicles and enhances the cost-effectiveness of the vehicles use.
- **Elimination of overload penalties.** The sensors inform the driver of the axles load. This allows to control the cargo weight and avoid penalties for exceeding load limit.
- **Reducing repair costs for vehicles' suspension.** When the truck is loaded properly, the service life of its suspension is much longer than in case of overloading; this saves repair costs.

1.2 Exterior view and delivery set



- 1** Position sensor - 1 pc.;
- 2** Specification - 1 pc.;
- 3** Signal cable 7.5 m (CABLE DFM.98.20.001) - 1 pc.

a) [GNOM DP A \(08001\)](#)



- 1** Position sensor - 1 pc.;
- 2** Specification - 1 pc.

b) [GNOM DP](#) / [GNOM DP CAN](#)

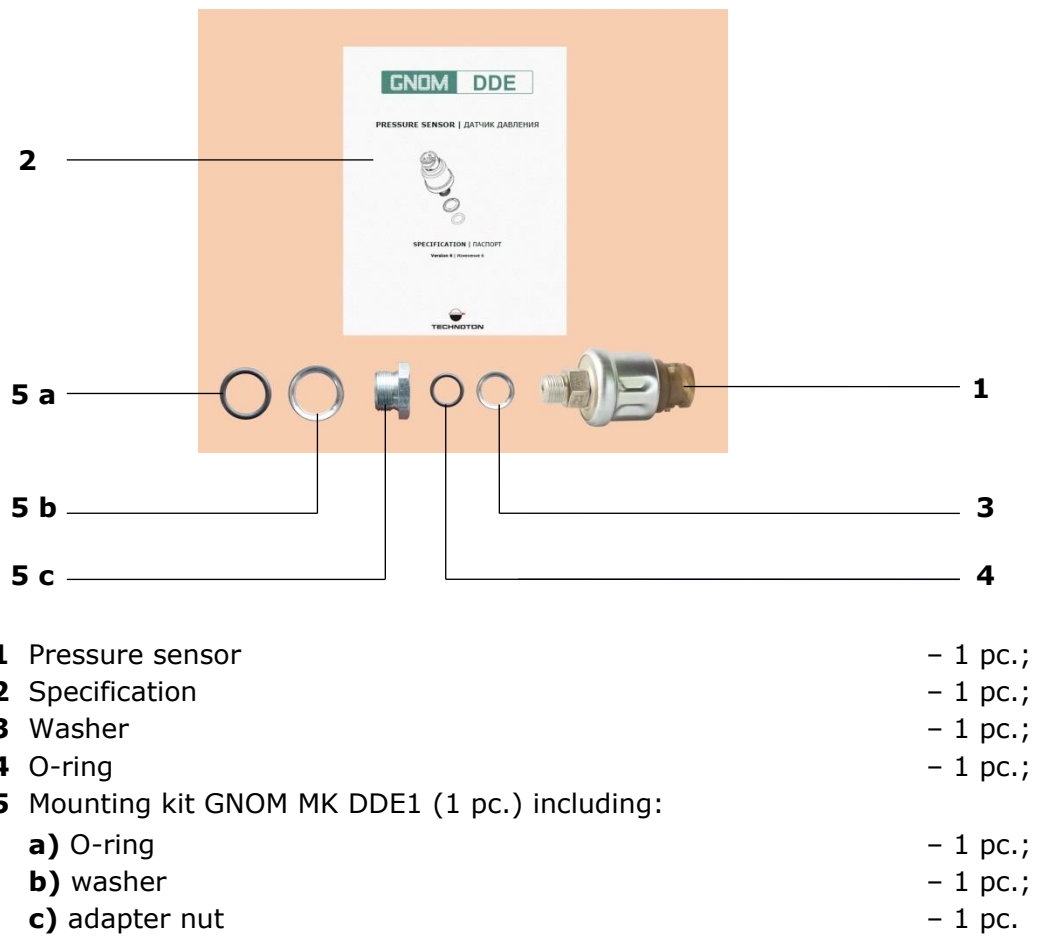

c) [GNOM DDE](#)

Figure 9 — External view of the delivery set for axles load sensors

1.3 Structure and operation principle

1) GNOM DP A / GNOM DP / GNOM DP CAN position sensor consists of the measuring unit **(1)** which contains the angle shift magnetoresistive transducer of the pivot lever, the pivot lever **(2)**, mounting bracket **(3)** and power supply connector **(4)**. The particularity of GNOM DP A model design is that the power supply connector is located at the end of the sensor interface cable **(5)** (see figures 10 a, b).

The principle of operation of the position sensor is based on the transformation of its lever rotation angle into the stabilized output voltage signal (for GNOM DP A / GNOM DP) or into digital data ([SPN 521719](#)) of CAN 2.0B interface (for GNOM DP CAN). The signal at the sensor output corresponds to the pivot lever angular position which varies depending on the [Vehicle](#) axle load.

2) GNOM DDE pressure sensor consists of the measuring unit **(1)** with the tensoresistive pressure transducer located inside, power supply connector **(2)**, inlet thread fitting **(3)** for compressed air with a mounting nut **(4)** (see figure 10 c).

GNOM DDE operation principle is based on transformation of compressed air pressure into output voltage. Tensoresistive bridge is used as a transducer. The output of the sensor generates stabilized analog voltage signal. Voltage signal varies depending on pressure in the Vehicle air suspension circuit coming through the inlet thread fitting to the transducer.

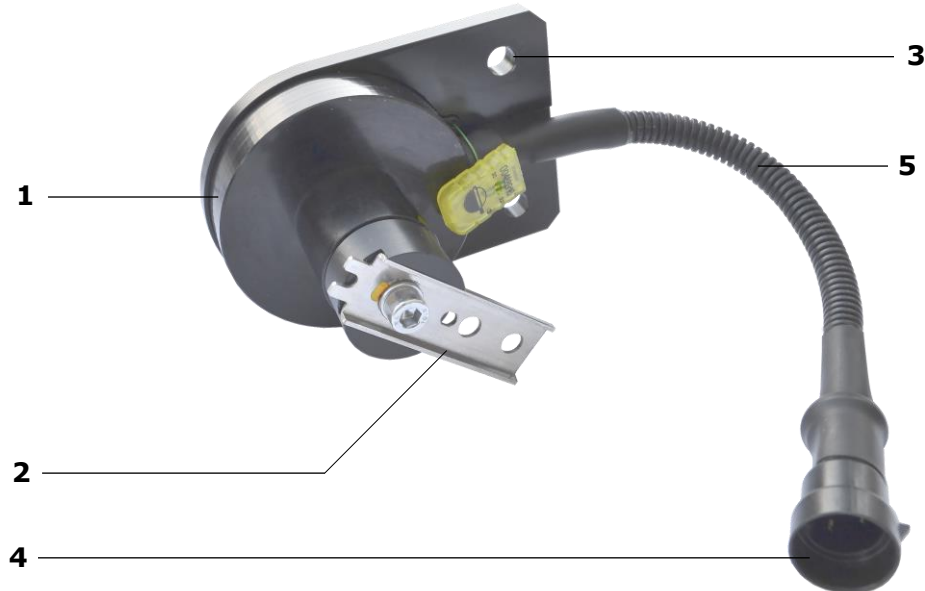

a) GNOM DP A (08001)

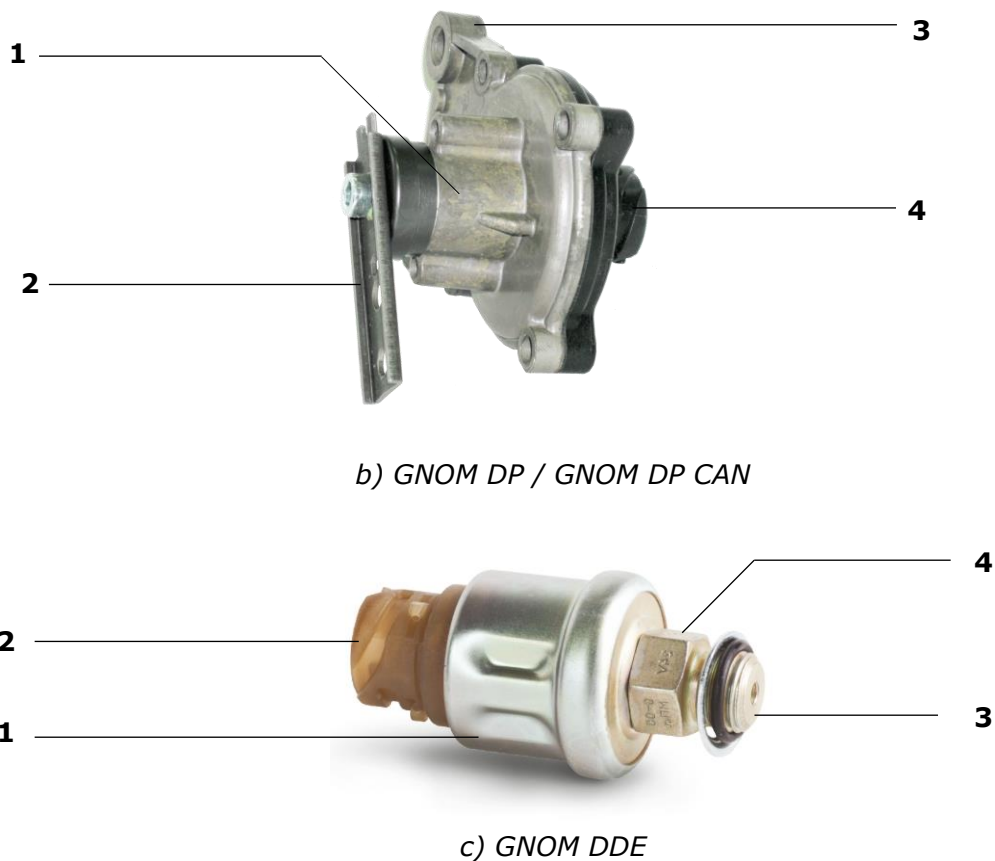

Figure 10 – Components of axles load sensors

In case of using [GNOM](#) as component of the transport [Telematics system](#), the correlation of the sensor output signal voltage and the [Vehicle](#) axle load values is established, in accordance with the calibration table. To create the calibration table, the obligatory **calibration** procedure is needed (see [2.7](#)).



IMPORTANT: Correct operation of GNOM sensors is impossible without the calibration table.

The calculation of the load values in the Telematics system may be carried out by: the [Telematics terminal](#), a display for visual monitoring Vehicle parameters (e.g. [MasterCAN Display 35](#)), a converter of signals (e.g. [MasterCAN DAC](#)), the software of the Vehicle transport monitoring system at the [Server](#).

1.4 Technical specifications

1.4.1 Main specifications

Table 1 — Main specifications of GNOM sensors

Parameter name, unit of measure	Value			
	GNOM DDE	GNOM DP	GNOM DP A	GNOM DP CAN
Supply voltage range, V	8...32		9...36	18...32
Rated power supply voltage, V	12/24			24
Type of output signal	Analog, voltage			Digital, CAN 2.0B interface (SAE j1939 protocol)
Output signal voltage range, V	0.25...3.80	1.54...3.46	1.0...7.0	—
Pressure measurement range, MPa	0...0.8*	—		
Lever rotation angle range, degrees	—	-40...+40		-80...+80
Permissible accuracy error limit of output signal generation, %, not more than	±2.5	±4.1	±2.5	—
Admissible accuracy error of data transferred to the output interface, % no more than	—			±0.8
Enclosure protection rating against the ingress of dust and moisture	IP55		IP65/67 (IEC 60529:2013)	IP55
Connection thread	M16x1.5 M22x1.5**	—		
Ambient operation temperature range, °C	-40...+80			
Vibration resistance	The maximum acceleration of 50 m/s ² in the frequency range from 10 Hz to 50 Hz for at least 8 h (GOST 3940, GOST R 50607)			
Shock resistance	Acceleration of 100 m/s ² with 100 shocks/min frequency			
Electromagnetic compatibility	<ul style="list-style-type: none"> • resistance to EMI (UNECE regulation 10); • electrostatic discharge (EDS) protection (GOST 30378); • protection against conducted interference on the supply lines (STB ISO 7637-2, GOST 28751); • protection against conducted interference on control and signal board circuits (STB ISO 7637-3, GOST 29157) 			
Weight, kg, not more than	0.2	0.3	0.45	0.3
Overall dimensions, mm, not more than	see 1.4.5			
Mean lifetime, years	5			
<p>* The sensor can withstand the overload with the input pressure up to 1.2 MPa. ** Using the adapter nut from the mounting kit GNOM MK DDE1.</p>				

1.4.2 Characteristics of GNOM DP A / GNOM DP / GNOM DDE output analog signals

The output signal of all GNOM sensors is stabilized and does not depend on the Vehicle onboard circuit voltage fluctuations.

1) **GNOM DP A / GNOM DP output signal value** is linearly dependent on lever rotation angle value (see figure 11).

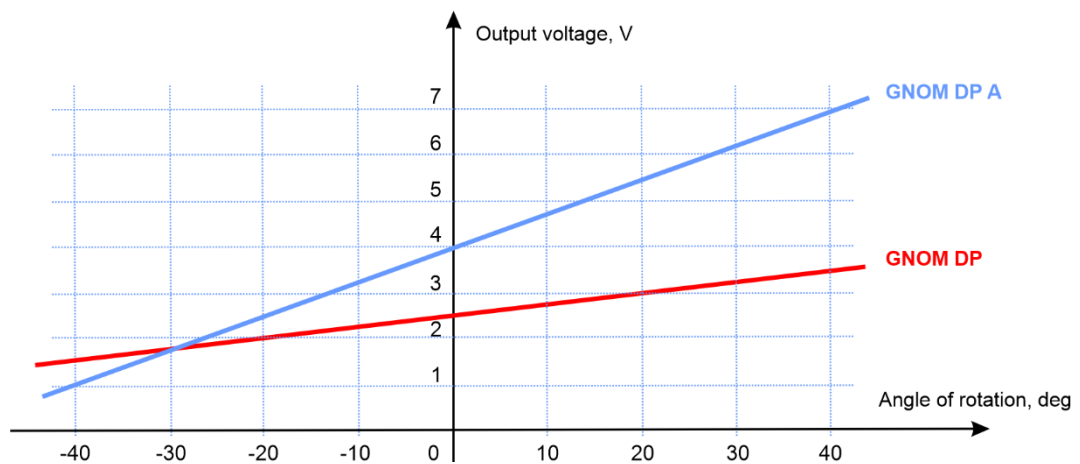

Figure 11 — Graphs of dependence of GNOM DP A / GNOM DP output voltage on the sensor pivot lever shift angle

Table 2 — Dependence of GNOM DP A / GNOM DP output voltage on the sensor pivot lever shift angle

Rotation angle of the sensor lever, degrees	Output voltage, V	
	GNOM DP A	GNOM DP
-40	1.00	1.54
-30	1.75	1.78
-20	2.50	2.02
-10	3.25	2.26
0	4.00	2.50
10	4.75	2.74
20	5.50	2.98
30	6.25	3.22
40	7.00	3.46

2) Output signal voltage value of [GNOM DDE](#) is linearly dependent on the value of pressure of compressed air on sensor output (see figure 12).

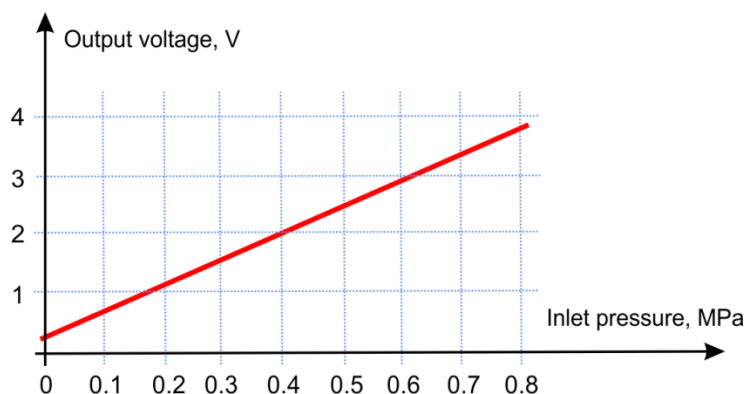

Figure 12 – Graph of GNOM DDE output voltage dependence on the sensor input pressure

Table 3 – GNOM DDE output voltage dependence on the sensor input pressure

Pressure at sensor inlet, MPa	Output voltage, V
0	0.25
0.1	0.70
0.2	1.20
0.3	1.55
0.4	2.00
0.5	2.50
0.6	2.95
0.7	3.30
0.8	3.80

1.4.3 Characteristics of GNOM DP CAN digital signal

GNOM DP CAN sensor has non-configurable CAN 2.0B output interface that meets SAE j1939 international standard.

The sensor output data are interpreted in conventional units (cu), have 12-bit digit capacity and are automatically transmitted every 10 ms in two low bytes of the data field at the rate of 250 kbit/s.

Table 4 – Data composition of GNOM DP CAN output message

Field number	Length	Parameter	Name
Shift Sensor PGN 65280 (0xFF00)			
1	2 bytes	SPN 521719	Rotation Angle
3	2 bytes	SPN 524001	Reserved
5	4 bytes	SPN 524007	Reserved

Table 5 – General characteristics of GNOM DP CAN output message

Parameter name	Value
PGN	65280
PDU Format	255
PDU Specific	0
Repetition Rate	10 ms
Priority	6
Bit Rate	250 kbit/s
Data Length	8 bytes
Source Address (SA)	218; 81...84 (can be chosen when ordering the sensor)
Frame Format	Extended

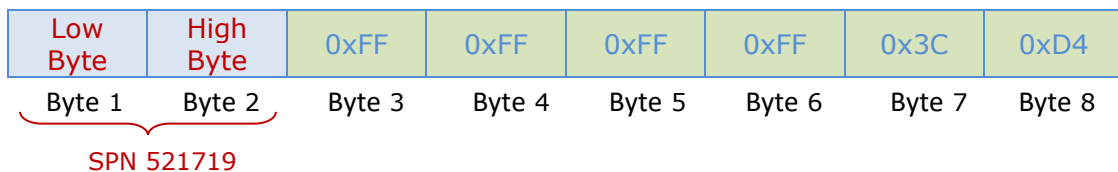
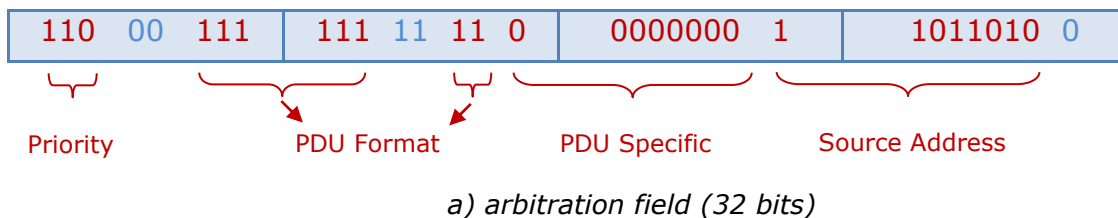

where Low Byte – low data byte;
 High Byte – high data byte;
 0xFF, 0x3C, 0xD4 – service data.

Figure 13 – The composition of GNOM DP CAN transmitted data packet

The value of GNOM DP CAN output data ([SPN 521719](#)) is linearly dependent on the sensor lever rotation angle and is calculated according to the formula (1).

$$0.04884 * \alpha - 100 = \text{SPN 521719, deg} \tag{1}$$

where α – value in decimal, cu;
0.04884 – resolution, deg;
-100 – offset, deg.

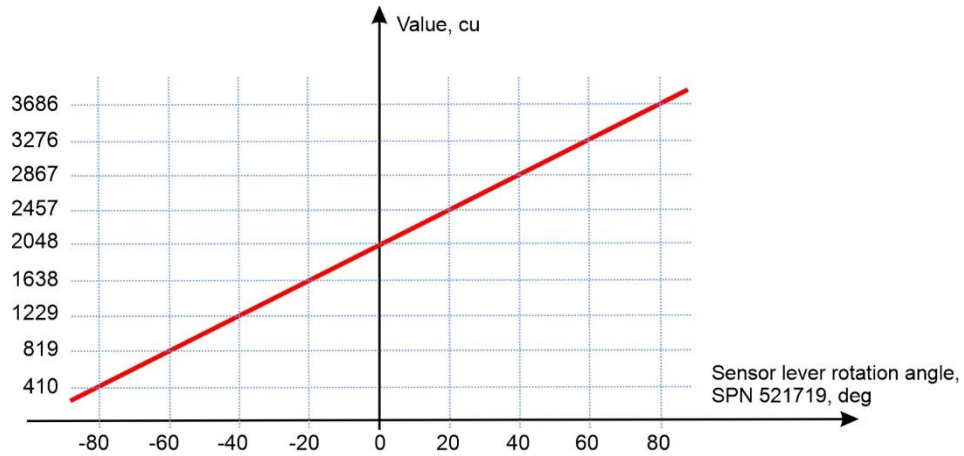

Figure 14 — Graph of GNOM DP CAN output data dependence on the sensor lever rotation angle

Table 6 — Correspondence of GNOM DP CAN output data to the sensor lever rotation angle

Sensor lever rotation angle SPN 521719, degrees	Value, cu
-80	410
-60	819
-40	1229
-20	1638
0	2048
+20	2457
+40	2867
+60	3276
+80	3686

The built-in software of the sensor enables you to monitor its quality of performance in real time. In case of any malfunction, the sensor sends a message error to CAN 2.0B output interface, instead of a standard data packet.

Data field (64 bytes)

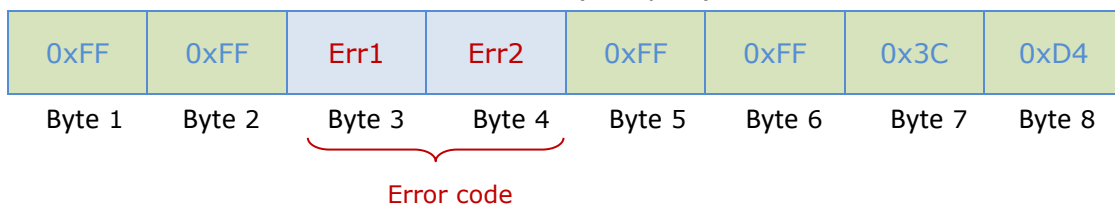

Figure 15 — Composition of a GNOM DP CAN error message

Table 7 — Description of error codes of GNOM DP CAN

Value		Description of error codes
Err1	Err2	
0x01	0xFF	Short circuit of the common output connection or the output line disruption, or +5 V line disruption or diagnostics mode
0x02	0xFF	Short circuit of the output to +5 V line, or the common output line disruption or diagnostics mode
0x55	0xAA	Alert timer triggered (period — once in a second)

1.4.4 Sensors and tracking devices compatibility

[GNOM](#) axles load sensors can be used together with [Telematics terminals](#) or other tracking devices whose inputs are compatible with parameters of the sensors output signals, in accordance with [1.4.2](#) and [1.4.3](#).

[Technoton](#) regularly conducts compatibility and mutual accuracy tests for sensors and different models of Terminals.

At Technoton website <https://www.jv-technoton.com/> you can find a [table](#) containing the current list of Declarations of compatibility of Telematics terminals from different manufacturers with GNOM sensors and other Technoton-made equipment.

Recommendations on GNOM sensors connection and equipment configuration are available at Technoton [technical support](#) service support@jv-technoton.com.

1.4.5 Overall dimensions

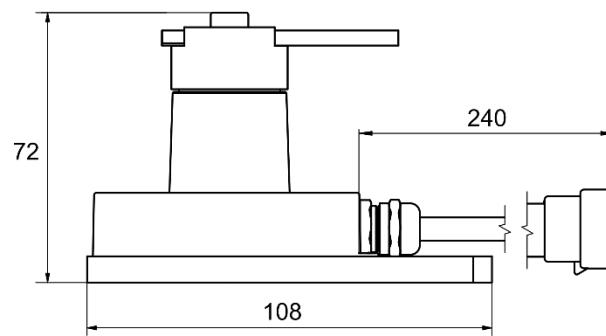
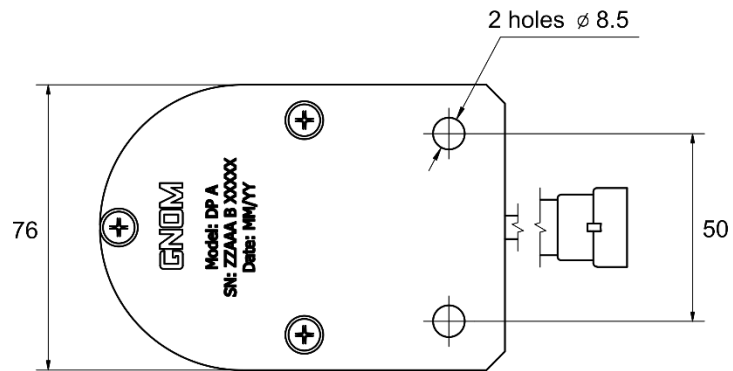

a) GNOM DP A (08001)

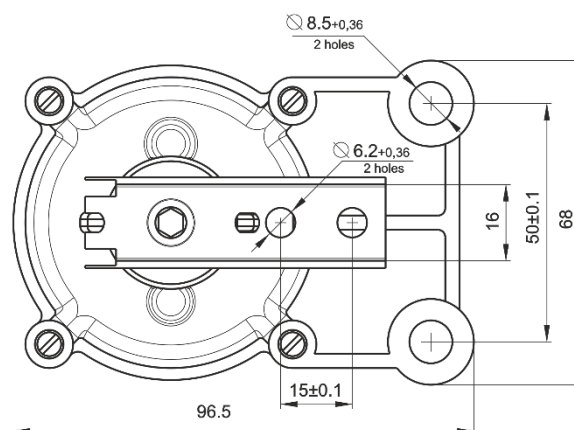
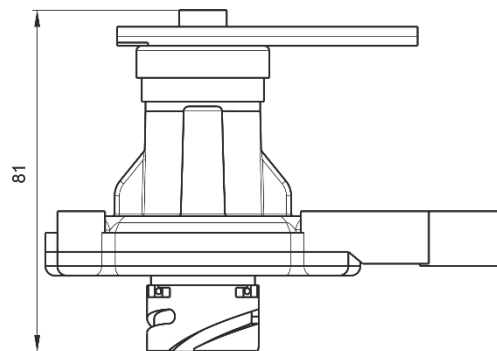

b) GNOM DP / GNOM DP CAN

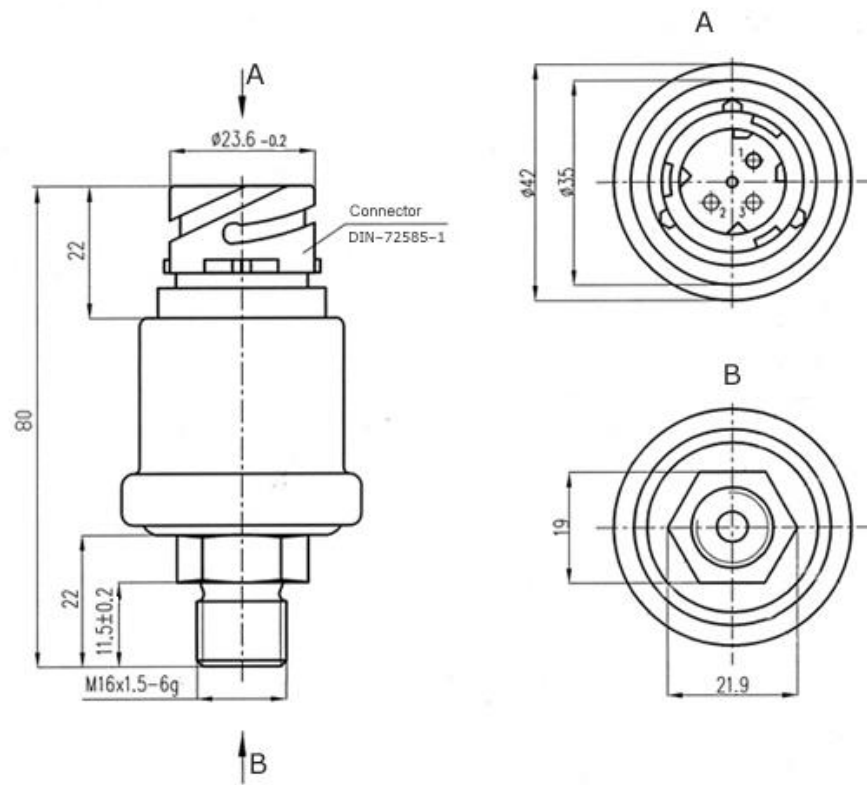

c) GNOM DDE

Figure 16 — Dimensions of axles load sensors

2 Mounting

This section contains general recommendations on [GNOM](#) sensors mounting.



ATTENTION: To ensure proper operation of GNOM, it should be mounted and electrically connected by specialist, who finished [official technical training](#) and was certified for that.

2.1 Exterior inspection prior to works start

It is necessary to conduct GNOM exterior inspection for the presence of the following possible defects arisen at transportation, storage or careless use:

- visible damage of the sensor parts;
- backlash of component parts or gaps between them.

Contact the supplier if any defects detected.

2.2 Vehicle status evaluation

You should evaluate [Vehicle](#) technical condition and make a conclusion about the possibility of [GNOM](#) sensor installation before starting any works.

Vehicle status evaluation includes:

- 1)** Checking the technical condition of the Vehicle leaf spring suspension elements for absence of faults and defects ([GNOM DP A](#) / GNOM DP / GNOM DP CAN).
Inspection of Vehicle air suspension circuit for damages and leakage of compressed air ([GNOM DDE](#)).
- 2)** Checking the voltage of the on-board Vehicle electric circuit with a voltage meter.
For 12 V Vehicles operating voltage should be in the range of 10 to 18 V.
For 24 V Vehicles voltage should be in range of 18 to 32 V.
- 3)** Checking Vehicle chassis ground. Resistance between any point on Vehicle chassis and the "-" terminal of the battery should not exceed 1 Ohm.

In case the Vehicle does not meet the required condition the customer should be notified to eliminate all the faults before GNOM mounting.

2.3 GNOM DP mounting

2.3.1 General instructions



WARNING: The procedure for mounting all models of position sensors — GNOM DP A (08001) / GNOM DP / GNOM DP CAN is quite identical. Therefore, only GNOM DP will be specified further on, while discussing methods of sensor mounting.



ATTENTION: Strictly follow safety rules of automobile repair works as well as local safety rules of the customer company when mounting GNOM DP sensor.

To mount GNOM DP on a [Vehicle](#), you need:

- [GNOM DP](#) position sensor;
- mounting kit (to be purchased separately):
 - [GNOM MK DP universal](#) — for mounting the sensor on three-axial Vehicles;
 - [GNOM MK DP 1-axle](#) — for mounting the sensor on two-axial Vehicles;
- signal cable:
 - [CABLE DFM.98.20.001](#) (included into the [delivery set](#)) — for connection of GNOM DP A (08001) model;
 - [041 cable](#) (to be purchased separately) — for connection GNOM DP;
 - [GNOM DP CAN sensor cable](#) / [S6 SC DP cable](#) (to be purchased separately) — for connection GNOM DP CAN;
- additional mounting brackets for GNOM DP and elements for GNOM MK DP (see figure 17) **manufactured from steel no less than 4 mm thick**, in accordance with schematic drawings made by the installer personnel;
- garage tools (sets of wrenches, sockets, screwdrivers, etc.);
- tape measure;
- volt-ohm meter.



Figure 17 — Examples of additional mounting brackets for position sensor and elements of mounting kit



IMPORTANT:

1) When fixing additional mounting brackets on the Vehicle chassis, **it is forbidden to drill the Vehicle frame and components of the transmission mechanism!**

2) **Spot weld is allowed for fixing the mounting brackets**, in case there are no suitable standard holes and locations allowing to fix the mounting plates with bolts.

2.3.2 Selection of mounting location and procedure for the sensor mounting



ATTENTION: A decision regarding [GNOM DP](#) mounting location and mounting scheme to be used is taken by the installer personnel based on the particularities of the specific Vehicle suspension design.

1) The location for mounting GNOM DP sensor is to be selected along the [Vehicle](#) lengthway symmetry line, between the wheels of the axle which is to be monitored, in the centre of the Vehicle frame cross bar (see figure 18).

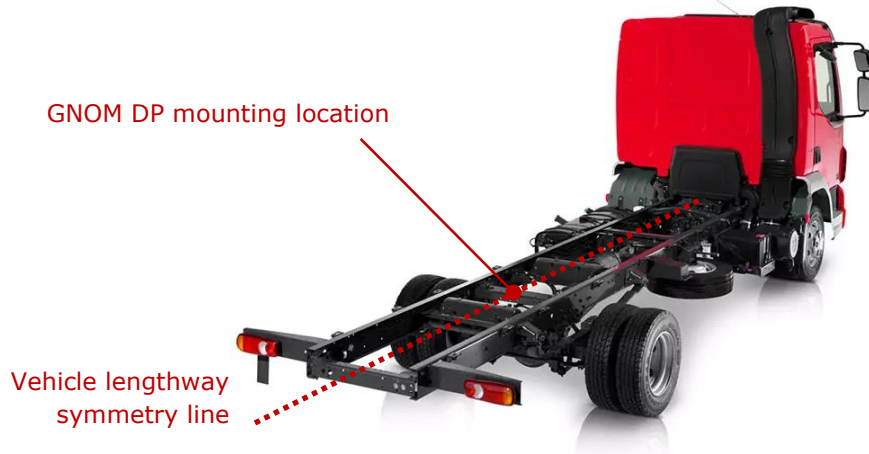

Figure 18 — Selection for GNOM DP mounting location for monitoring the Vehicle axle load

GNOM DP mounting location on the Vehicle frame must be as close as possible to the Vehicle frame which is to be monitored so as to ensure the correct mounting of the elastic element, lever and rod of mounting kit.

All the mounting kit components mentioned must be in the same plane and have no bends. The mounting location of the elastic element on the Vehicle axle must be as close as possible to the Vehicle lengthway symmetry line. This will reduce the impact of the Vehicle rolls and variations of suspension travel on the sensor operation, in case any of the Vehicle wheels runs into a road surface warp (see figure 19).

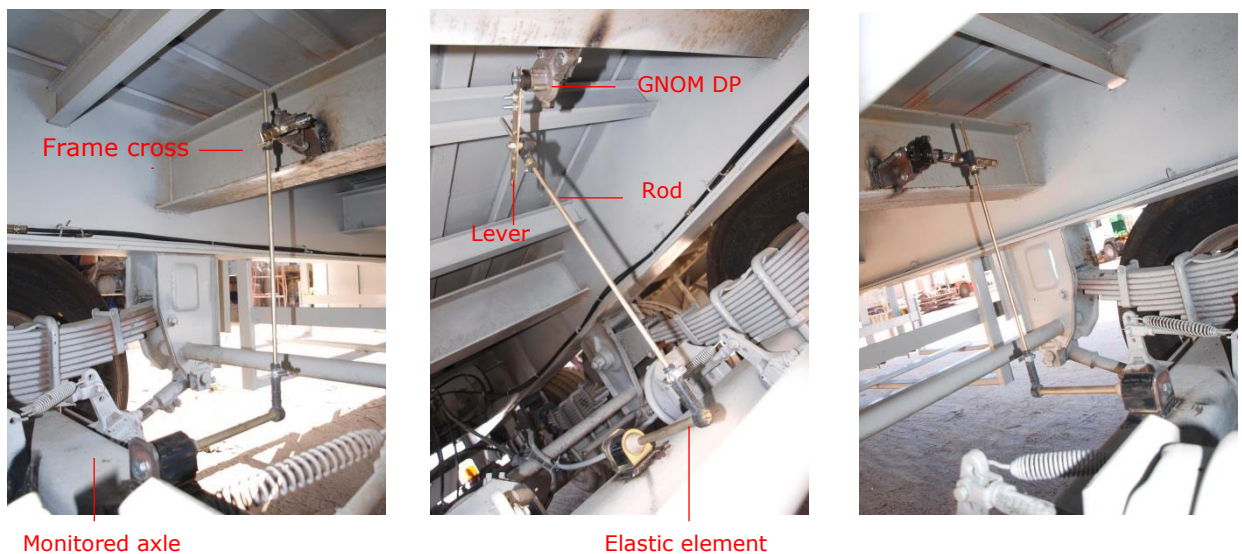

Figure 19 — Example of GNOM DP mounting location to monitor the semitrailer axle load

2) The lever length (L) and the rod length (H) from mounting kit are selected experimentally, specifically on the Vehicle to be equipped. The range of changing the angle of rotation of the lever of the mounted GNOM DP must be within the entire Vehicle suspension travel (Δ) (see figure 20).

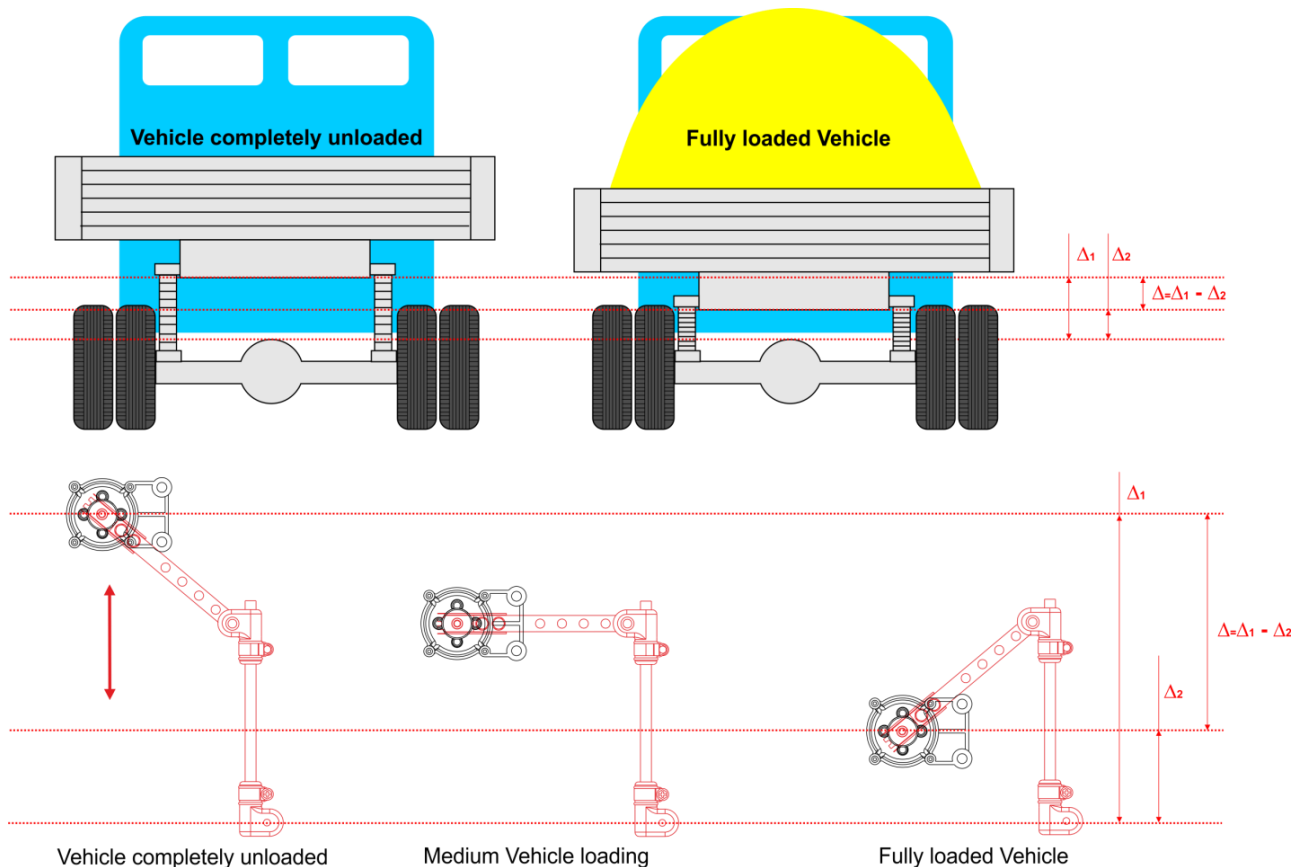

Figure 20 – Defining the Vehicle suspension travel

Initial adjustment of the rod height (H) and the lever length (L) (see figure 21) should be performed on a completely unloaded Vehicle.

The length of the lever (L) can be calculated according to the formula (2)

$$L = 0.8 \cdot \Delta, \text{ mm} \quad (2)$$

where $\Delta = \Delta_1 - \Delta_2$, mm – suspension travel defined according to the following values measured with a tape measure:

Δ_1 , mm – distance from the frame to the monitored axle measured on the completely unloaded Vehicle;

Δ_2 , mm – distance from the frame to the monitored axle measured on the maximally loaded Vehicle, mm.

You are to perform the final adjustment of the rod height (H) and the lever length (L) on the maximally loaded [Vehicle](#). To accomplish this, fix the rod coupling with clamps, check the lever position and, if needed, slightly adjust the rod height (H) and the lever length (L).

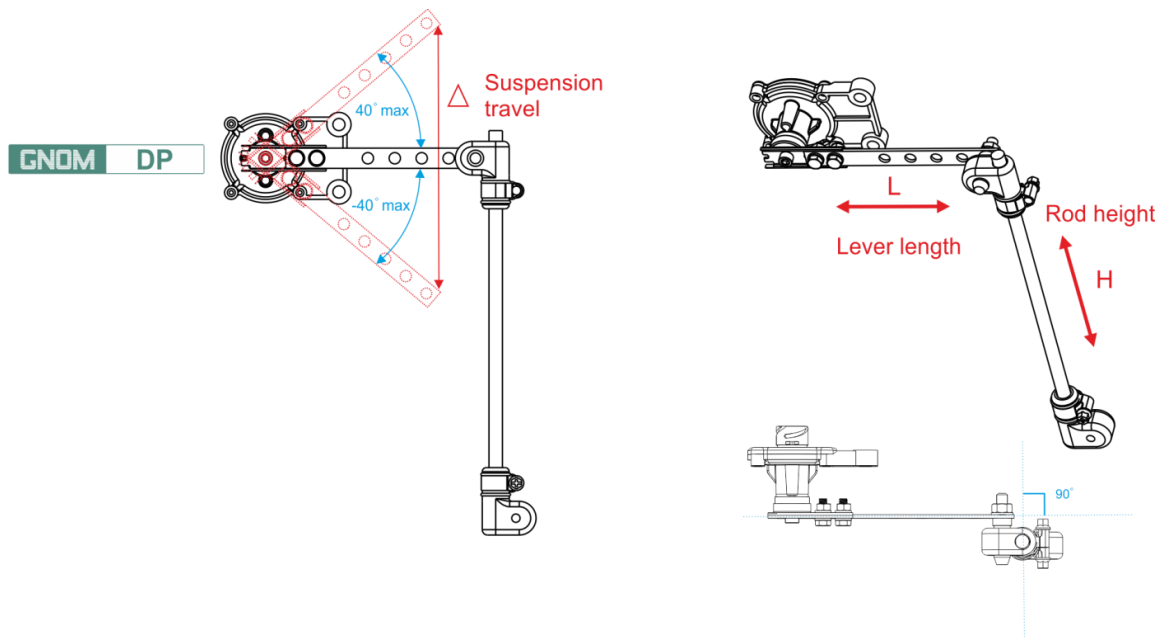

Figure 21 — Adjusting GNOM MK DP rod and lever for GNOM DP mounting



WARNING: Avoid mechanical deformation (bending) of sensor pivoted lever and mounting kit lever and rod when mounting [GNOM DP](#).

2.3.3 Stages of mounting the sensor according to the typical scheme for a two-axial Vehicle

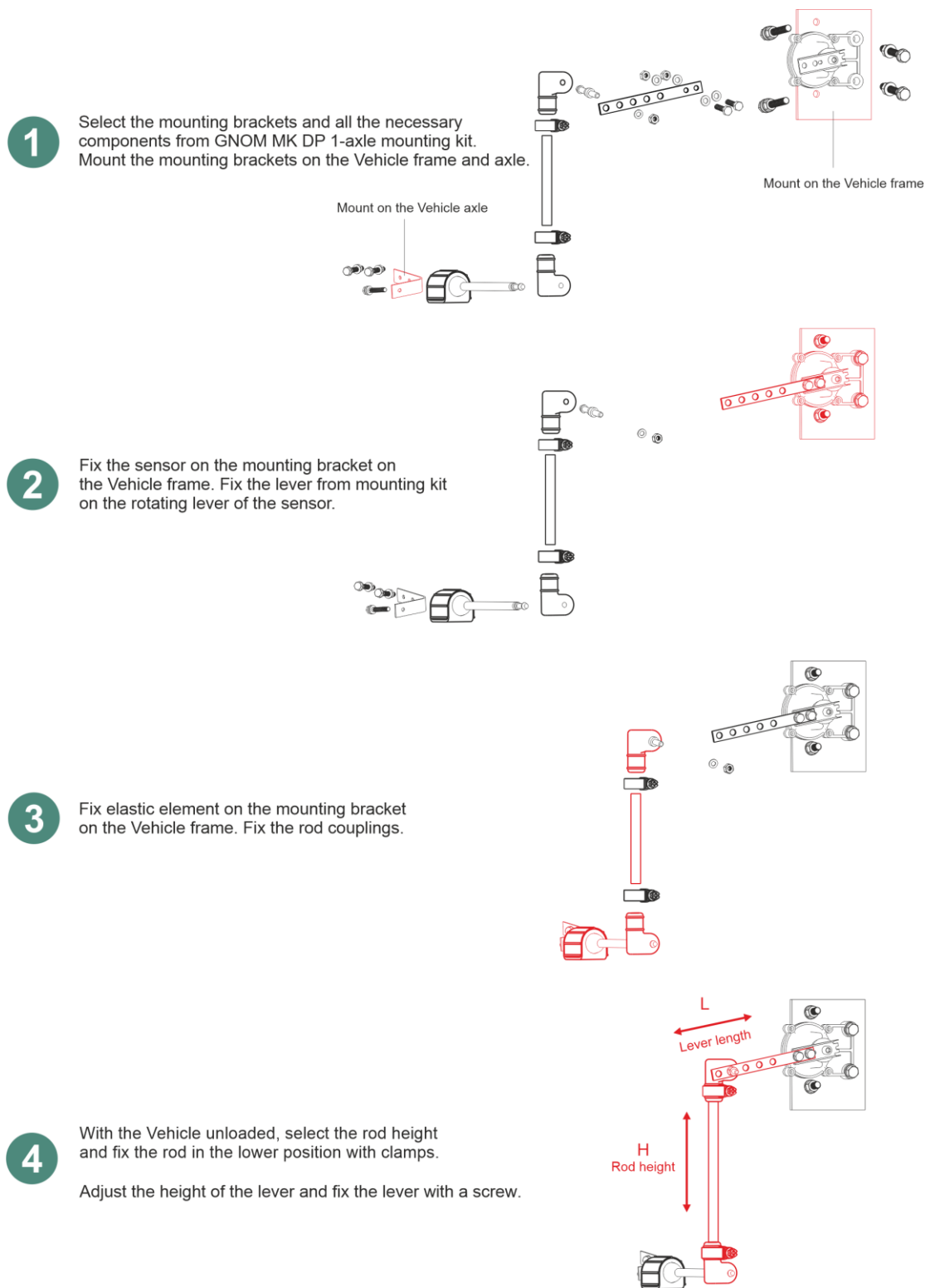

Figure 22 — Stages of mounting [GNOM DP](#) according to the typical scheme for a two-axial Vehicle

Figure 23 shows [GNOM DP](#) mounting on the rear axle of Vehicles with two axles 4x2.

Mounting bracket for [GNOM MK DP 1-axle](#) elastic element is fixed to the rear axle with standard bolts.

Mounting bracket for the sensor is fixed to the frame with spot welding.

To exclude the lever 180° throw-over in case the wheels of the monitored [Vehicle](#) axle run into road surface warps, we recommend to use the mounting bracket with special limiters (see figure 23 a).

Lever rotation angle limiters



a) elastic element is mounted in the same plane as the pivoted lever of the sensor



b) elastic element is perpendicular to the pivoted lever of the sensor

Figure 23 — GNOM DP mounting on Vehicles with two axles 4x2

2.3.4 Stages of mounting the sensor according to the typical scheme for a three-axial Vehicle

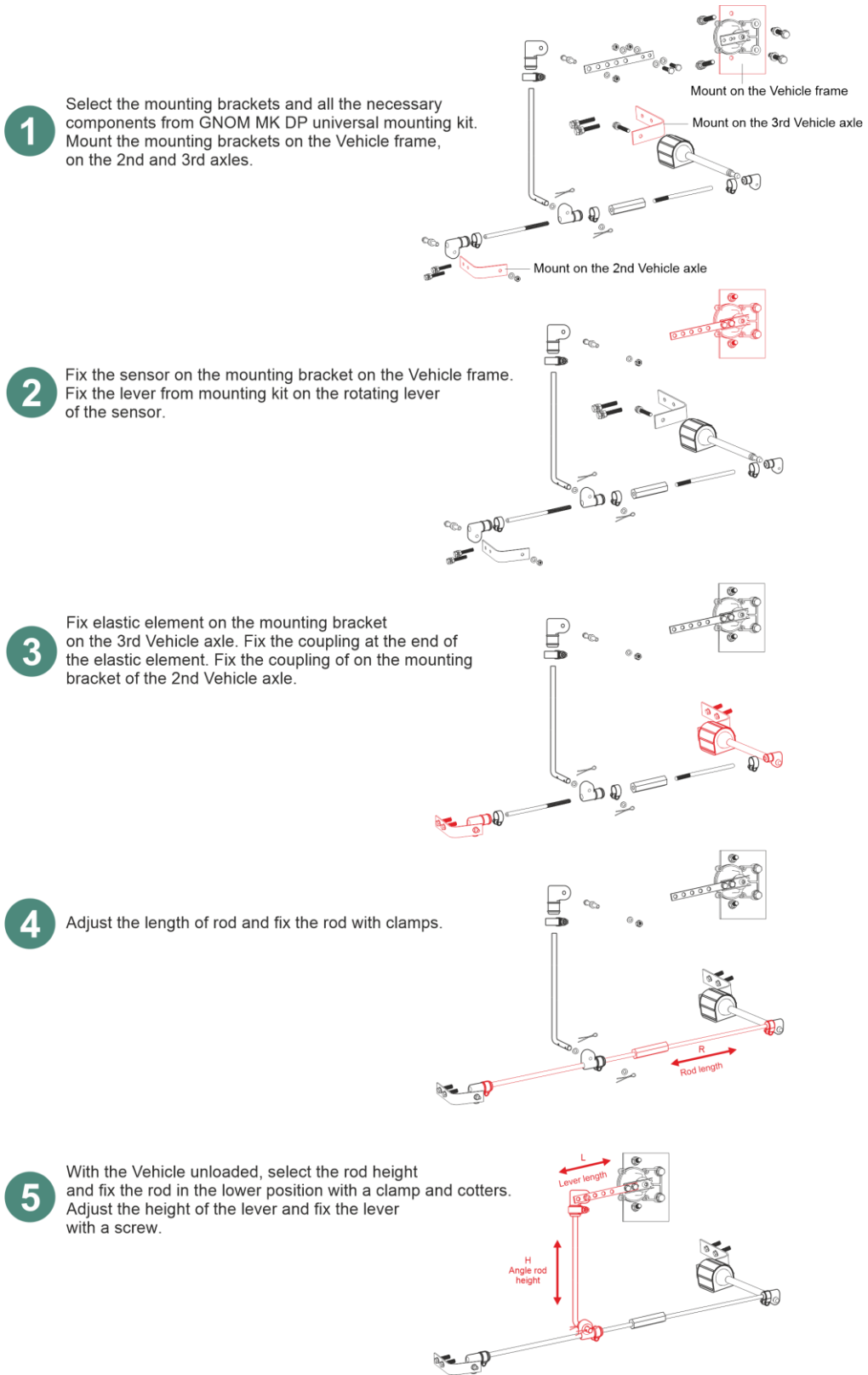

Figure 24 — Stages of mounting **GNOM DP** according to the typical scheme for a three-axial Vehicle

See figure 25 for [GNOM DP](#) mounting on the rear bogie of the Vehicle with three axles 6x4. Mounting brackets for [GNOM MK DP universal](#) rods are fixed to the axles of the rear bogie with standard bolts.

The mounting bracket for the sensor is fixed to the frame technological sockets between the axles of the rear bogie (see figure 25 a).

If there are no sockets in the [Vehicle](#) frame use spot welding for fixing the bracket (see figure 25 b).



a) fixing the sensor to the Vehicle frame with bolts

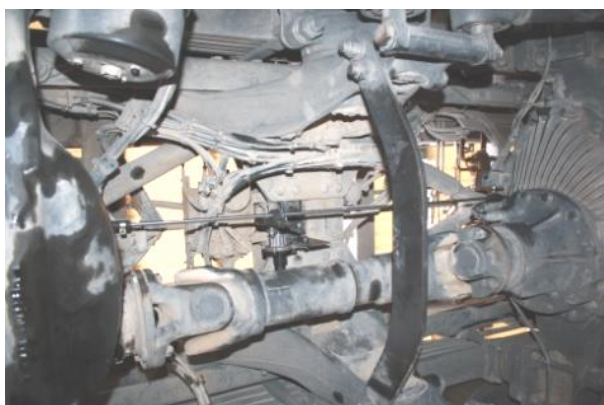

b) fixing the sensor to the frame with spot welding

Figure 25 — GNOM DP mounting on Vehicles with three axles 6x4

Photos showing examples of mounting [GNOM](#) axle load sensors can be found at <https://www.jv-technoton.com/>, section [Gallery of Mounting Technoton Equipment](#).

2.4 GNOM DDE mounting

2.4.1 General instructions

To mount [GNOM DDE](#) on a Vehicle, you need:

- GNOM DDE pressure sensor;
- signal cable — [cable 040-02](#) (to be purchased separately);
- mounting kit: GNOM MK DDE1 (included into the [delivery set](#)) or [GNOM MK DDE2](#) (to be purchased separately);
- automobile hand tool kit (sets of spanners, screwdrivers, etc.).

ATTENTION – WORK WITH HIGH PRESSURE!



- 1)** Mounting of GNOM DD should be performed by the personnel authorized to perform any operations on the equipment with high pressure.
- 2)** Strictly follow safety rules of automotive repair works as well as local safety rules of the customer company when mounting GNOM DDE.
- 3)** Before GNOM DDE mounting operations you should set the [Vehicle](#) air suspension into the service mode and **release pressure in the compressed air system!**

2.4.2 Selecting mounting location and scheme

Depending on the design of the air suspension of various Vehicles and convenience of [GNOM DDE](#) installation works the following installation location and mounting schemes are applied:

1) The simplest scheme is mounting GNOM DDE into a **standard air supply thread hole of the suspension air balloon**. The thread hole is plugged with a bolt (see figure 26). The sensor is mounted instead of the bolt into M16x1.5 thread hole or into M16x1.5 using adapter nut M22x1.5 according to **scheme 1** (see figure 27).



Figure 26 — GNOM DDE mounted into suspension air balloon

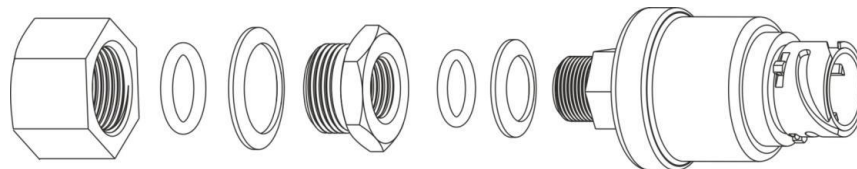
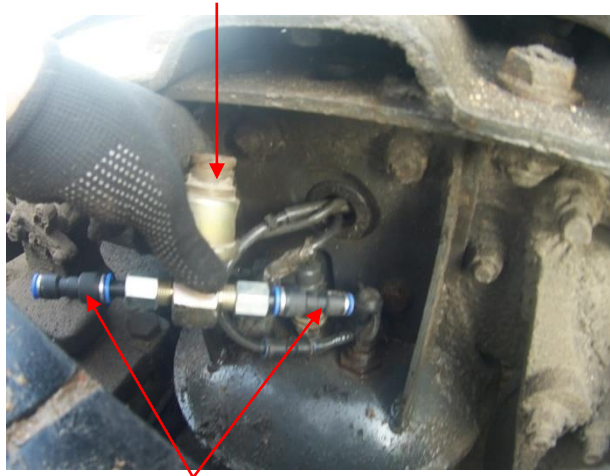

Figure 27 — GNOM DDE mounting order according to scheme 1

2) Any suitable **air supply pipes fitting** can be selected for GNOM DDE mounting when using adapter fitting (T splitter) of the [GNOM MK DDE2](#) (see figure 28).

GNOM DDE sensor prepared for mounting in the air suspension circuit



Collet fitting connectors from 6 mm to 8 mm (purchased separately)

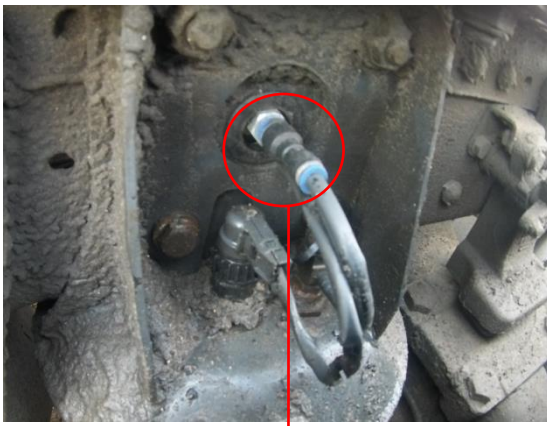

Location for connecting air supply lines of the air suspension

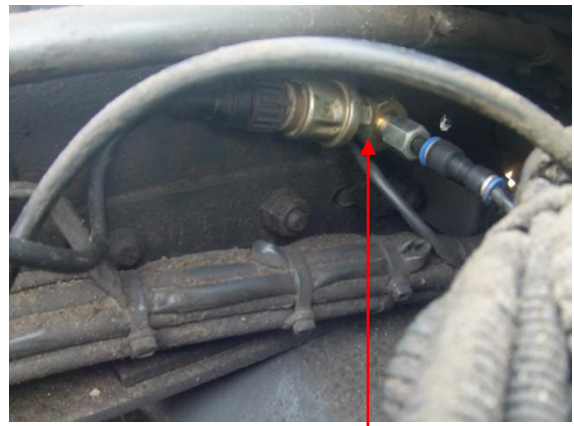

Fitting connector from GNOM MK DDE2 GNOM MK DDE2 mounting kit

Figure 28 — Using T splitter for GNOM DDE mounting in air supply pipes fitting

According to **scheme 2** [GNOM DDE](#) can be mounted into M22x1.5 thread hole with the resumption of compressed air supply pipeline (see figure 29).

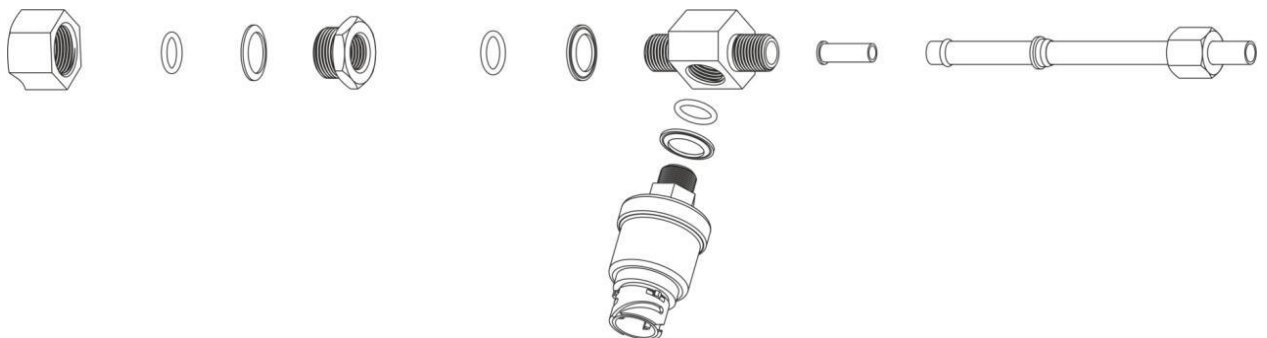

Figure 29 — GNOM DDE mounting order according to scheme 2

3) According to mounting **scheme 3** [GNOM DDE](#) is mounted into the **cut of $\varnothing=8$ mm suspension supply pipeline**. [GNOM MK DDE2](#) mounting kit is used (see figure 30).

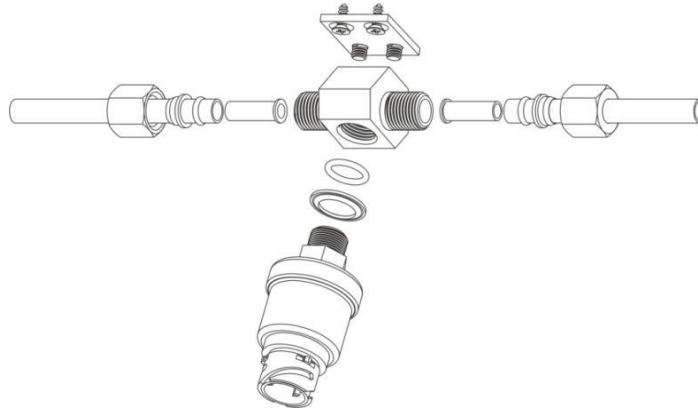

Figure 30 — GNOM DDE mounting scheme 3

4) Using mounting kit GNOM MK DDE2 the sensor can be installed into **$\varnothing=8$ mm supply pipeline fitting** (see figure 31).

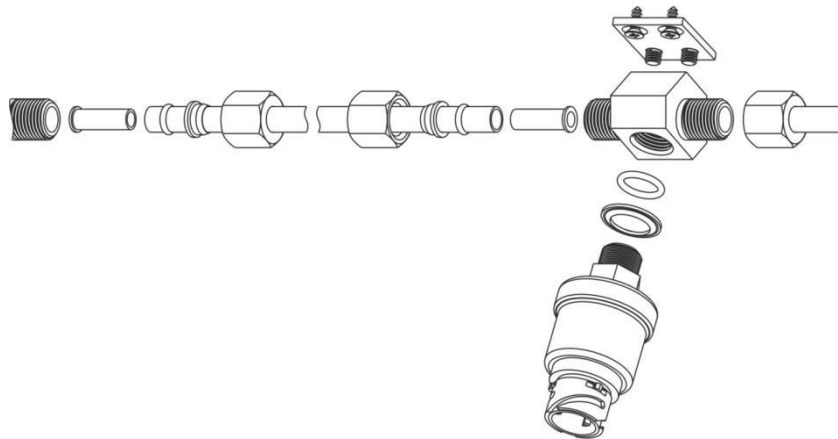

Figure 31 — GNOM DDE mounting scheme 4

Photos showing examples of mounting [GNOM](#) axle load sensors can be found at <https://www.jv-technoton.com/>, section [Gallery of Mounting Technoton Equipment](#).

2.4.3 Rules for installation works

Follow the **rules** for works on pneumatic equipment when mounting [GNOM DDE](#):

- Pipelines having cracks, tears, dents and thread defects are not allowed for mounting.
- Do not tighten any bolts, nuts, or other connection elements that are under pressure.
- Do not bend the pipeline or other elements of the air suspension system.
- Make sure the internal area of the pneumatic lines is clean when mounting pipelines.
- Pipelines fastening must be reliable, stress-free, and must have a margin to compensate temperature length changes.
- The maximum tightening torque of plastic air supply pipelines is 60 N•m.

2.5 Electrical connection

WARNINGS:



- 1) To ensure proper operation of GNOM sensors, their electrical connection must be performed only by certified specialists, who have undergone [technical training at the company](#).
- 2) During electrical connection of GNOM, you are to follow strictly health and safety rules for conducting repair operations, as well as health and safety requirements established at the company.

Power of [GNOM](#) sensors is supplied from the [Vehicle](#) on-board.

IMPORTANT:



- 1) Before you start connection operations, you need to switch off the Vehicle electrical circuits by means of the battery switch or release terminals of the wires connected to the battery.
- 2) Pay special attention to checking the proper quality of the Vehicle chassis ground. The impedance between any point of the Vehicle chassis and "-" terminal of the battery or between terminals of the chassis ground switch must not exceed 1 Ohm.
- 3) The feed wire "+" and the chassis wire "-" must be connected to the same sockets of the Vehicle onboard circuit, where the appropriate wires of the Telematics terminal (tracking device) are connected.
- 4) When connecting GNOM power supply to the Vehicle onboard circuit, it is recommended to insert **fuses** (purchased separately) (see figure 33 a). The nominal fuse current should be no more than 2 A.
- 5) It is **strongly recommended** to lay GNOM signal cable together with the standard Vehicle electrical wiring at ambient temperature above zero, with obligatory cable ties fixing its position every 50 cm (see figure 32).

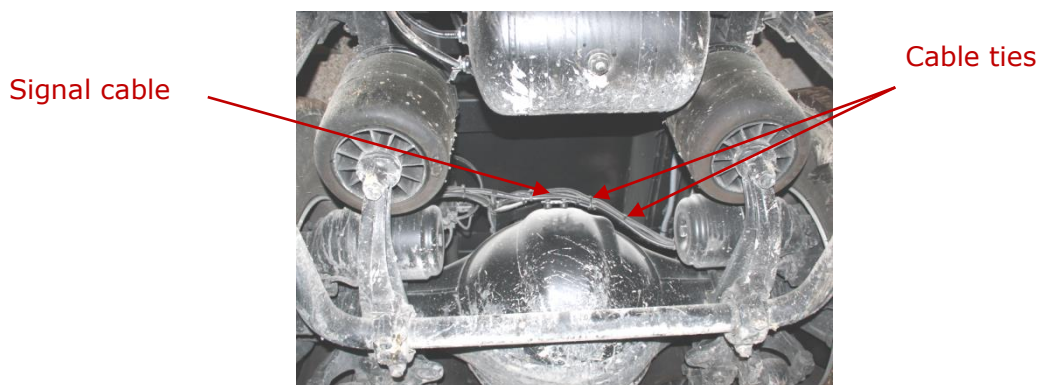
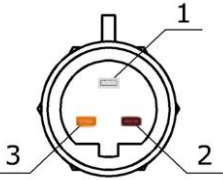

Figure 32 — Laying GNOM signal cable

1) The electrical connection of [GNOM DP A](#) (08001) is performed using [CABLE DFM.98.20.001 signal cable](#) from the [delivery set](#), in accordance with the sensor connector pinout and designation of the signal cable wires, according to table 8.

Table 8 – GNOM DP A (08001) electrical connection

GNOM DP A connector pinout	Connector Contact Number	Signal cable wire marking	Signal cable wire color	Circuit designation	Signal parameters
	1	OUT	White	Output signal (see 1.4.2)	Analog, voltage 1.0...7.0 V
	2	GND	Brown	Ground “-”	—
	3	VBAT	Orange	Supply “+”	Analog, voltage 9...36 V
<p>Manufacturer reserves the right to modify wire colors.</p>					

2) The electrical connection of [GNOM DP](#) is performed in accordance with the designation of the sensor connector contacts and designation of the signal cable wires, according to table 9.

Table 9 – GNOM DP electrical connection

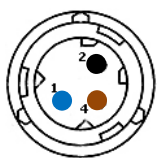
GNOM DP connector pinout	Connector Contact Number	Signal cable wire marking	Signal cable wire color	Circuit designation	Signal parameters
	1	VBAT	Blue	Supply “+”	Analog, voltage 8...32 V
	2	GND	Black	Ground “-”	—
	4	OUT	Brown	Output signal (see 1.4.2)	Analog, voltage 1.54...3.46 V
<p>Notes</p> <p>1 GNOM DP signal cable – 041 cable (to be purchased separately) is used for GNOM DP electrical connection (see 2.9.4).</p> <p>2 Manufacturer reserves the right to modify wire colors.</p>					

3) The electrical connection of [GNOM DP CAN](#) is performed in accordance with the designation of the sensor connector contacts and designation of the signal cable wires, according to table 10.

Table 10 – GNOM DP CAN electrical connection

GNOM DP CAN connector pinout	Connector Contact Number	Signal cable wire marking	Signal cable wire color	Circuit designation	Signal parameters
	1	VBAT	Green	Supply "+"	Analog, voltage 18...32 V
	2	GND	Yellow	Ground "-"	—
	3	CANH	Red	Output interface CAN 2.0B (see 1.4.3)	Digital, CAN-High (SAE j1939)
	4	CANL	Brown		Digital, CAN-Low (SAE j1939)
<p>Notes</p> <p>1 GNOM DP CAN signal cable – GNOM DP CAN sensor cable / S6 SC DP cable (to be purchased separately) is used for GNOM DP CAN electrical connection (see 2.9.4).</p> <p>2 Manufacturer reserves the right to modify wire colors.</p>					

4) The electrical connection of [GNOM DDE](#) is performed in accordance with the designation of the sensor connector contacts and designation of the signal cable wires, according to table 11.

Table 11 – GNOM DDE electrical connection

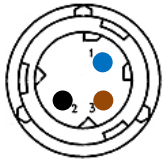
GNOM DDE connector pinout	Connector Contact Number	Signal cable wire marking	Signal cable wire color	Circuit designation	Signal parameters
	1	VBAT	Blue	Supply "+"	Analog, voltage 8...32 V
	2	GND	Black	Ground "-"	—
	3	OUT	Brown	Output signal (see 1.4.2)	Analog, voltage 0.25...3.80 V
<p>Notes</p> <p>1 GNOM DDE signal cable – 040-02 cable (to be purchased separately) is used for GNOM DDE electrical connection (see 2.9.4).</p> <p>2 Manufacturer reserves the right to modify wire colors.</p>					

Terminals are recommended for electrical connection of power supply wires and quick splice **connectors** for output signal wire connection (see figure 33).



a) fuse with holder



b) terminals



c) connectors

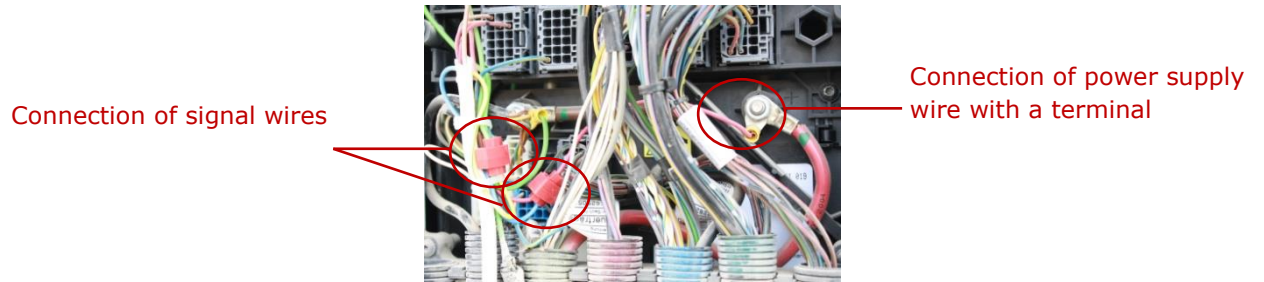

d) example of using terminals and connectors when connecting GNOM sensors

Figure 33 — GNOM electrical connection

2.6 Sealing

It is strongly recommended to seal the connector of the sensor and the points of cable wires connection with optional sealing cords and disposable plastic seals (to be purchased separately) to prevent unauthorized interference into GNOM operation (see figure 34).

To seal the connector put the sealing cord through the special holes on GNOM body and connection power supply connector. Then put the free ends of the cord through two holes in the center of the plastic seal. Clicking the seal will lock the cord. It will be impossible to unlock the seal without breaking it.

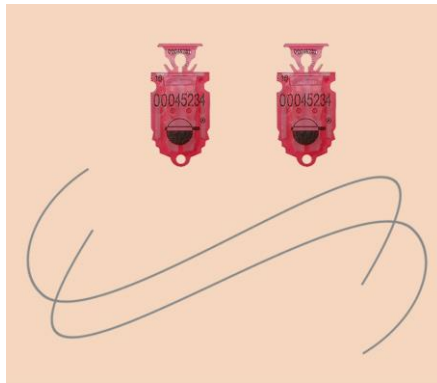

Figure 34 — Disposable plastic seals and sealing cord*

* Design of the seal supplied can differ from the one displayed in figure 34.

2.7 Calibration

GNOM sensors are supplied ready for use and do not require any adjustment.



IMPORTANT: For correct operation of GNOM sensors within the transport [Telematics system](#), you need to conduct the **calibration** procedure without which correct operation of GNOM sensors is impossible.

In the process of calibration you need to create a calibration table determining the dependence of GNOM sensor output voltage on the axle load or on how much [Vehicle](#) is loaded (see figure 35).

Depending on purpose of monitoring, there are the following types of calibration:

1) "Axles load monitoring" calibration in the process of which the dependence of the mounted GNOM sensors output voltage on different values of axle load is determined. To identify values of axle load in points of the calibration table, we recommend to use a special scale for weighing each axle of the Vehicle (see figure 36 a).

2) "Vehicle load monitoring" calibration in the process of which the dependence of the mounted GNOM sensors output voltage on different values of Vehicle load is determined. For this purpose, we recommend to employ a special scale for weighing the entire Vehicles (see figure 36 b).

Reference points for creating the calibration table are selected within the range from the minimal axle load (no load on the Vehicle) to the maximum load possible (maximally loaded Vehicle).

The Telematics system calculates axle load values, in accordance with points of the created calibration table. To this end, you need to enter the data of the calibration table points into the software of the monitoring system [Server](#) (e.g. into [ORF 4](#) / [ORF 5](#) Telematics service), or into the [Terminal](#) (e.g. [CANUp 27](#) online Telematics gateway), or into [MasterCAN Display 35](#) display of CAN j1939/S6 bus or into [MasterCAN DAC](#) digital to analog converter) (see [annex D](#)).

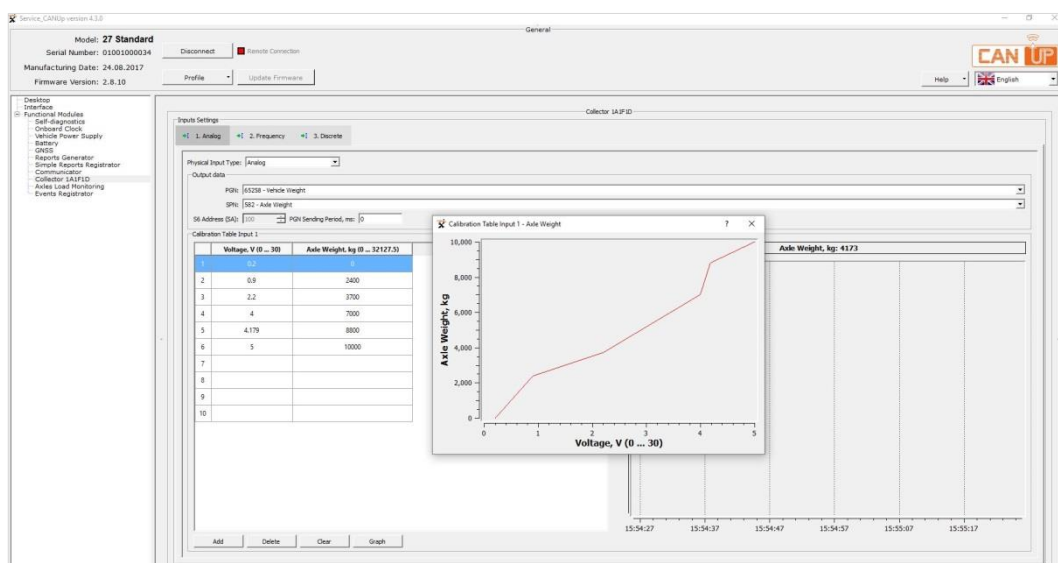

Figure 35 — Example of the calibration table created for the output signal of GNOM DDE connected to the analog input of CANUp 27 Standard

You can conduct the calibration using one of the following methods:

1) Loading of given weights (pieces of known weight)

Load weight is calculated according to formula (3)

$$\text{Load weight} = \text{Total weight of loaded pieces} \quad (3)$$

2) Weighing with axle weighing scales

- the most loaded axle of loaded Vehicle with unknown weight;

With such calibration the system won't be able to process load weight

- the whole Vehicle loaded with unknown weight;

Load weight is calculated according to formula (4)

$$\text{Load weight} = \text{Weight of fully loaded Vehicle} - \text{Weight of empty Vehicle} \quad (4)$$

IMPORTANT: During the calibration process you must:



1) Follow health and safety rules, as well as general regulations for cargo loading/unloading, positioning and fixing which are established at a particular road transport company for respective types of Vehicles.

2) Employ only special Vehicle weighing scales (see figure 36).



a) for weighing a single Vehicle axle



b) for weighing the entire Vehicle

Figure 36 — Examples of Vehicle weighing scales to be used in the calibration process

2.8 GNOM accuracy check

To check the operational accuracy of the [GNOM](#) sensor a test must be performed.

2.8.1 Purpose of the test

GNOM accuracy check test is needed to determine the reduced error of axle load measurement of the [Vehicle](#).

2.8.2 Test preparation

Install [GNOM](#) and make all necessary electrical connections to power supply and tracking device. Carry out all the works according to GNOM and tracking device manuals.

2.8.3 Testing

To check the accuracy of axle load measurement use the method of most loaded axle weighing.

The procedure includes the following steps for unknown weight calibration:

- 1)** Switch on the ignition.
- 2)** Load the Vehicle with a cargo (not less than 1/2 of maximum load capacity). The load should be evenly distributed along the Vehicle body.
- 3)** Put the most loaded axle on the scales and record the value into report.
- 4)** Unload the Vehicle partially (not less than 1/4 of maximum load capacity).
- 5)** Put the most loaded axle on the scales and record the value into report.
- 6)** Load the previously unloaded cargo back to the Vehicle.
- 7)** Put the most loaded axle on the scales and record the value into report.
- 8)** Calculate and record accuracy error values for loaded and unloaded Vehicle into report.

See [annex A](#) for a template of check test report and accuracy error calculation formulae.

2.9 Accessories

[Technoton](#) offers to purchase **high quality accessories** for mounting [GNOM](#) sensors.

2.9.1 Mounting kit GNOM MK DP universal

Mounting kit **GNOM MK DP universal** (hereinafter [GNOM MK DP universal](#)) is used for [GNOM DP A](#) / GNOM DP / GNOM DP CAN mounting on three-axial Vehicles with leaf spring suspension. See figure 37 for GNOM MK DP universal contents.

GNOM MK DP universal contains only high-quality components designed for mounting on [Vehicles](#).

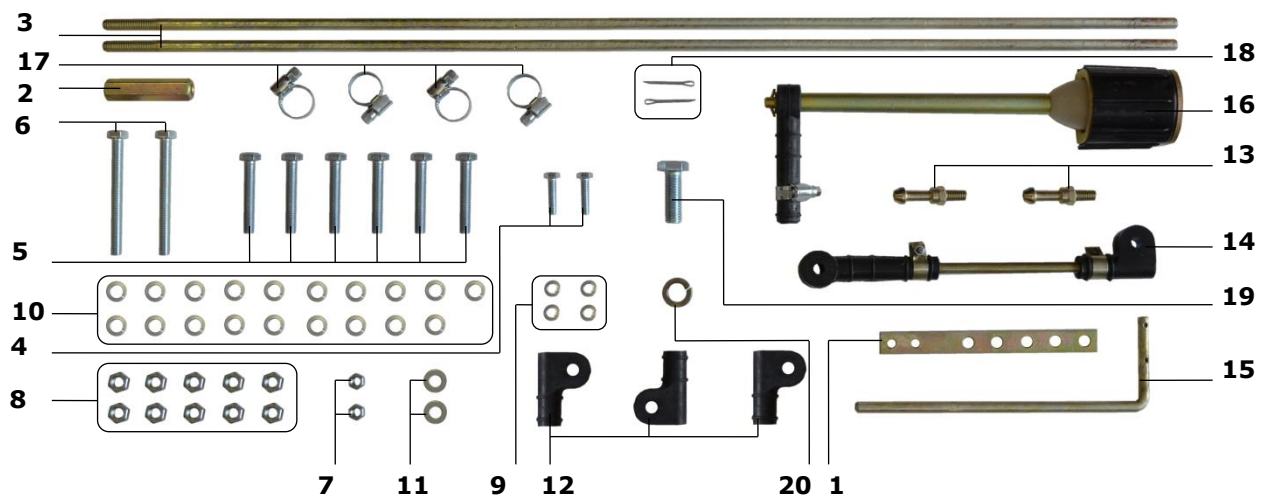

1 Lever	- 1 pc.;
2 Sleeve	- 1 pc.;
3 Rod	- 2 pcs.;
4 Bolt M6x25	- 2 pcs.;
5 Bolt M8x50	- 6 pcs.;
6 Bolt M8x80	- 2 pcs.;
7 Nut M6	- 2 pcs.;
8 Nut M8	- 10 pcs.;
9 Spring washer M6	- 4 pcs.;
10 Spring washer M8	- 19 pcs.;
11 Washer M8	- 2 pcs.;
12 Rod coupling	- 3 pcs.;
13 Pivot bolt	- 2 pcs.;
14 Regulator rod	- 1 pc.;
15 Angular regulator rod	- 1 pc.;
16 Elastic element	- 1 pc.;
17 Clamp	- 4 pcs.;
18 Cotter	- 2 pcs.;
19 Bolt M12x35	- 1 pc.;
20 Spring washer M12	- 1 pc.

Figure 37 — Mounting kit GNOM MK DP universal contents



ATTENTION: [Manufacturer](#) reserves the right to change the set of GNOM MK DP universal and replace the components with equivalent without prior customer notice.

2.9.2 Mounting kit GNOM MK DP 1-axle

Mounting kit **GNOM MK DP universal** (hereinafter [GNOM MK DP 1-axle](#)) is used for [GNOM DP A](#) / GNOM DP / GNOM DP CAN mounting on two-axial Vehicles with leaf spring suspension. See figure 38 for GNOM MK DP 1-axle contents.

GNOM MK DP 1-axle contains only high-quality components designed for mounting on [Vehicles](#).

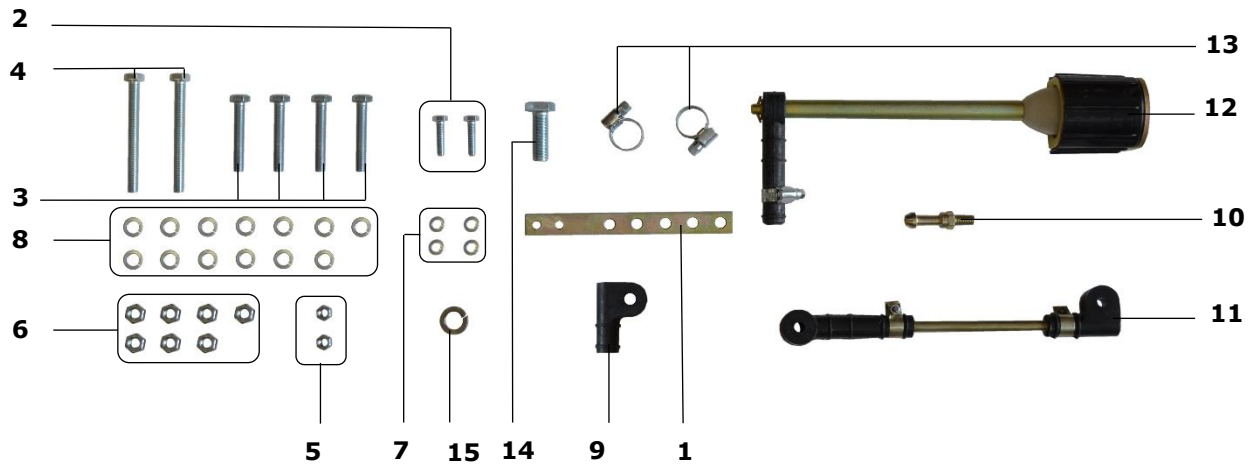

1 Lever	- 1 pc.;
2 Bolt M6x25	- 2 pcs.;
3 Bolt M8x50	- 4 pcs.;
4 Bolt M8x80	- 2 pcs.;
5 Nut M6	- 2 pcs.;
6 Nut M8	- 7 pcs.;
7 Spring washer M6	- 4 pcs.;
8 Spring washer M8	- 13 pcs.;
9 Rod coupling	- 1 pc.;
10 Pivot bolt	- 1 pc.;
11 Regulator rod	- 1 pc.;
12 Elastic element	- 1 pc.;
13 Clamp	- 2 pcs.;
14 Bolt M12x35	- 1 pc.;
15 Spring washer M12	- 1 pc.;

Figure 38 — Mounting kit GNOM MK DP 1-axle contents



ATTENTION: [Manufacturer](#) reserves the right to change the set of GNOM MK DP 1-axle and replace the components with equivalent without prior customer notice.

2.9.3 Mounting kit GNOM MK DDE2

[GNOM MK DDE2](#) mounting kit is designed to mount [GNOM DDE](#) sensor in the Vehicle air suspension circuit, in accordance with **mounting schemes 2/3/4** (see [2.4.2](#)).

GNOM MK DDE2 (see figure 39) contains only high-quality components specially designed for use in [Vehicle](#) air suspension system.



ATTENTION: [Manufacturer](#) reserves the right to change the set of GNOM MK DDE2 and replace the components with equivalent without prior customer notice.

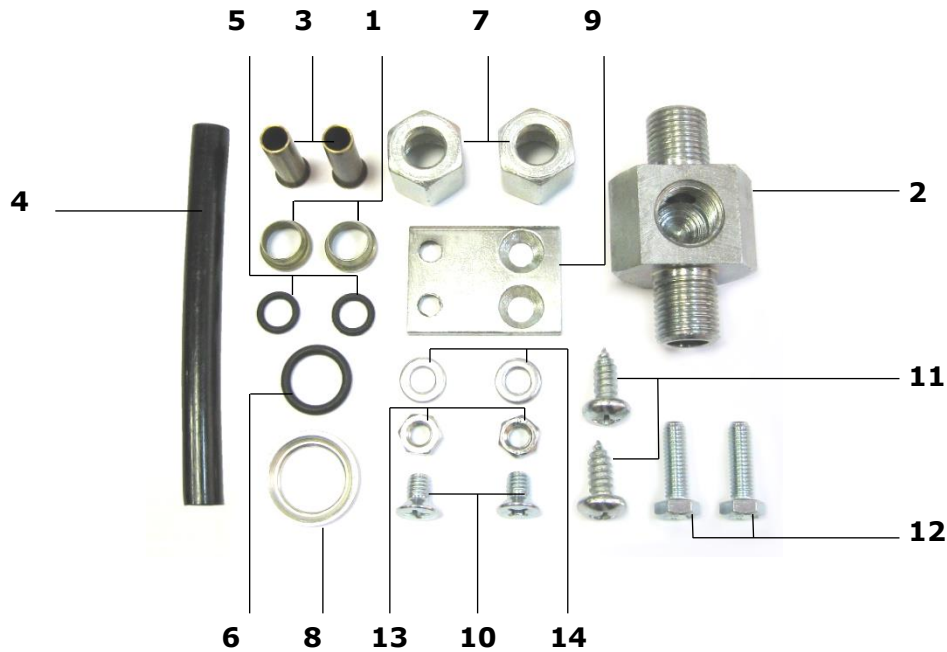

1 Conical sleeve	- 2 pcs.;
2 Fitting adapter (T splitter)	- 1 pc.;
3 Nipple	- 2 pcs.;
4 Pipeline Ø=8 mm	- 1 pc.;
5 O-ring	- 2 pcs.;
6 O-ring	- 1 pc.;
7 Swivel nut	- 2 pcs.;
8 Washer 16	- 1 pc.;
9 Mounting bracket	- 1 pc.;
10 Screw M6x8	- 2 pcs.;
11 Self-tapping screw 6.3x13	- 2 pcs.;
12 Bolt M6x20	- 2 pcs.;
13 Nut M6	- 2 pcs.;
14 Washer M6	- 2 pcs.;

Figure 39 — Mounting kit GNOM MK DDE2

2.9.4 Signal cables





Table 12 — Signal cables for GNOM sensors electrical connection

External view of the cable and its socket	Designation (Name)	Purpose and description
	CABLE DFM.98.20.001 (GNOM DP A sensor signal cable)	Designed for GNOM DP A electrical connection to analog input of the tracking device and to the Vehicle onboard circuit power supply. Cable length is 7.5 meters. Included into GNOM DP A delivery set.
	041 cable (GNOM DP sensor signal cable)	Designed for GNOM DP electrical connection to analog input of the tracking device and to the Vehicle onboard circuit power supply. Cable length is 8 meters. The cable is not a part of GNOM DP delivery set and should be ordered additionally.
	040-02 cable (GNOM DDE sensor signal cable)	Designed for GNOM DDE electrical connection to analog input of the tracking device and to the Vehicle onboard circuit power supply. Cable length is 12 meters. The cable is not a part of GNOM DDE delivery set and should be ordered additionally.
	GNOM DP CAN sensor cable (GNOM DP CAN sensor signal cable)	Designed for GNOM DP CAN* electrical connection to CAN (SAE j1939) input of the tracking device and to the Vehicle onboard circuit power supply. Cable length is 8 meters. The cable is not a part of GNOM DP CAN delivery set and should be ordered additionally.
	S6 SC DP cable (GNOM DP CAN sensor signal cable)	Designed for connection of GNOM DP CAN* sensor to the section of S6 cable system which is located outside the cabin. Cable length is 2 meters. The cable is not a part of GNOM DP CAN delivery set and should be ordered additionally.
<p>* You may find designations of models of additional cables and other elements of S6 cable system that may be needed for GNOM DP CAN connection by means of S6 Technology in CAN j1939/S6 Telematics interface Operation manual.</p>		

2.9.5 Optional accessories

The following accessories are recommended for [GNOM](#) mounting (see table 13).

Table 13 – GNOM mounting accessories

View	Label	Description	Application	Supply options
	N-Type Coiled Cable 4m	Semitrailer spiral cable	To connect the Telematics equipment mounted on the semitrailer to the Telematics equipment mounted on the tractor truck	Material for sockets – plastic, for 24 V onboard circuit, length is 4 m
	N-Type Metal Socket	Semitrailer cable socket	To connect the sensor signal cable mounted on the semitrailer to the semitrailer spiral cable	Material for sockets – metal, for 24 V onboard circuit
	N-Type Plastic Socket			
	64221-3533110	Elastic element	To mount GNOM DP sensor	Included into GNOM MK DP mounting kits

3 Axle load monitor

For visual monitoring the axle load by the [Vehicle](#) driver and for warning of exceeding the maximum axle load, we recommend to use **MasterCAN Display 35 G (“Truck”) display of CAN j1939/S6 bus** (further on — [MasterCAN Display 35 G](#)), developed by [Technoton](#) in combination with GNOM sensors (see figure 40).

MasterCAN Display 35 G is designed for visual monitoring parameters of truck tractors equipped with a standard CAN-bus, [Units](#) and analog sensors.

Power is supplied to MasterCAN Display 35 G from the Vehicle onboard circuit; MasterCAN Display 35 G is fully compatible with [GNOM DDE](#) / [GNOM DP A](#) / GNOM DP analog sensors. It is allowed to connect to the display up to two GNOM sensors in any combination of sensor models.



IMPORTANT: In order to display readings of [GNOM DP CAN](#) digital sensor, you need to employ **only** the model of CAN j1939/S6 bus display **MasterCAN Display 35 U (“Universal”)**. Besides, you can also additionally connect to the display up to two analog GNOM sensors of any models (see figure 44).

MasterCAN Display 35 G has 27 preset screens with values of [SPN](#) received via [CAN j1939/S6 Telematics interface](#) and one screen with converted signals from analog inputs (see [annex C](#)).



Figure 40 — MasterCAN Display 35 G exterior view

Table 14 — [MasterCAN Display 35 G](#) main specifications

Parameter, measuring unit	Value
Digital interface	CAN j1939/S6
Analog input, Voltage (resistance is 140 kOhms), V	0.5...10
Analog input, Frequency (amplitude 8...10 V), kHz	0.01...10
Power supply voltage range, V	9...45
Maximal current consumption at supply voltage 12/24 V, mA, not more than	100/50
Temperature range, °C	-10*...+60
Ingress protection rating	IP40
Liquid-crystal display (LCD)	128x64, monochrome, with automatic and manual adjustment of backlighting
Weight, kg, not more than	0.25
* If the ambient temperature is below -10 °C, LCD display of MasterCAN Display 35 G switches off automatically, but the device itself is active and operative. If the temperature rises above -10 °C, LCD display switches on automatically.	

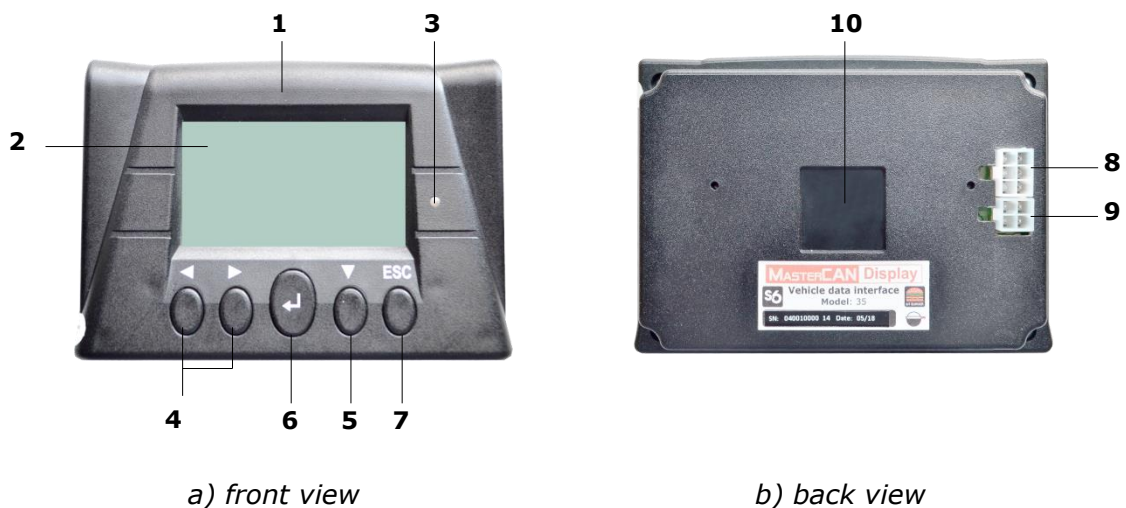

- 1** – body with electronic module inside;
- 2** – LCD with backlight;
- 3** – ambient light sensor for automatic adjustment of LCD brightness;
- 4** – horizontal selection buttons;
- 5** – vertical selection button;
- 6** – confirmation button;
- 7** – escape (cancel) button;
- 8** – **S6** socket (for connecting to CAN j1939/S6 interface and onboard electrical network of Vehicle);
- 9** – **SENS** socket (input for connecting voltage/frequency automotive sensors);
- 10** – groove for fixing mounting plate to back cover.

Figure 41 – MasterCAN Display 35 G design

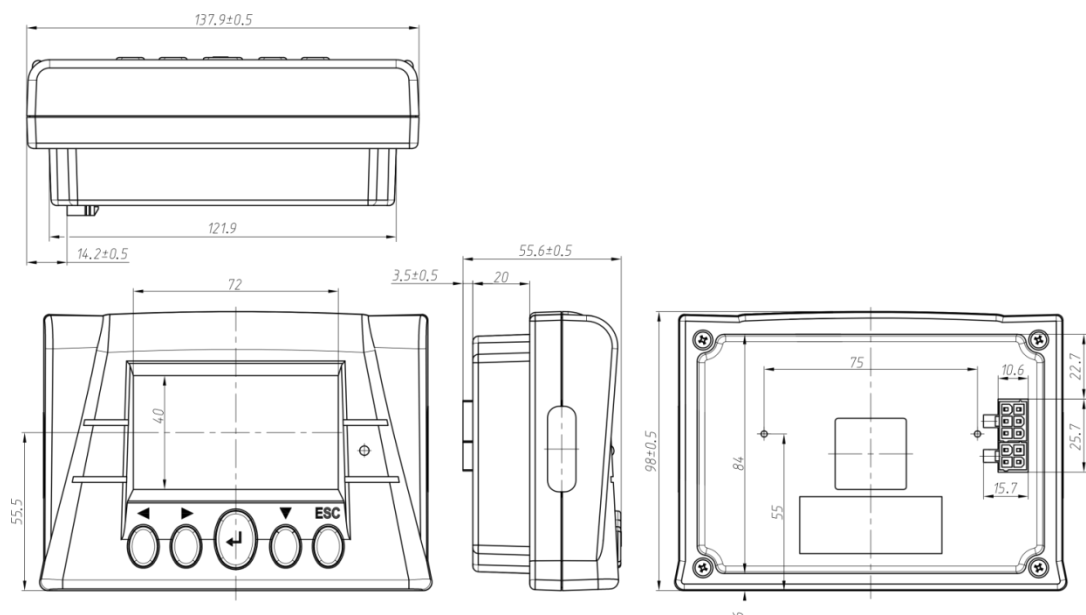

Figure 42 – [MasterCAN Display 35 G](#) overall dimensions

We recommend to mount MasterCAN Display 35 G in the [Vehicle](#) driver’s cabin. The most suitable location for MasterCAN Display 35 G mounting is the upper portion of the dashboard, so that the information screen could be within the sight of the driver (see figure 43).



a) place of installation



b) fixing

Figure 43 — Mounting of MasterCAN Display 35

General recommendations regarding MasterCAN Display 35 G electrical connection are similar to those regarding [GNOM](#) sensors connection (see [2.5](#)). MasterCAN Display 35 G is electrically connected, in accordance with the designation of contacts of its **S6** and **SENS** connectors, the marking and color of wires of respective signal cables, according to table 15 (see details in [MasterCAN Display 35 operation manual](#)).

Table 15 — Designation of contacts of **S6** connectors of MasterCAN Display 35 G and S6 signal cable

Connector Pinout	Connector Contact Number	Wire Marking	Wire Color	Circuit Designation	Signal Parameters
<p>S6 socket of MasterCAN Display 35:</p> <p>S6 plug of S6 signal cable:</p>	1	VBAT	Orange	Power "+"	Analog, voltage 9...45 V
	2	GND	Brown	Ground "-"	—
	3	CANH	Blue	CAN HIGH	Digital, CAN 2.0B, SAE j1939 Standard
	4	CANL	White	CAN LOW	
	5	KLIN	Black	K-Line	Digital, ISO 14230 Standard

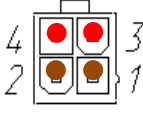
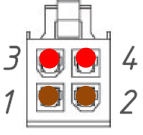
Connector Pinout	Connector Contact Number	Wire Marking	Wire Color	Circuit Designation	Signal Parameters
<p>SENS socket of MasterCAN Display 35:</p>  <p>SENS plug of SENS signal cable:</p> 	1	2_AFIN-	Brown	Frequency/ Voltage input 2	see 1.4.2
	3	2_AFIN+	Red		
	2	1_AFIN-	Brown	Frequency/ Voltage input 1	
	4	1_AFIN+	Red		

[Manufacturer](#) reserves the right to modify wire colors.

Examples of electrical connection of MasterCAN Display 35 for displaying data of axles load received by means of GNOM sensors are provided in figures 44 and 45.

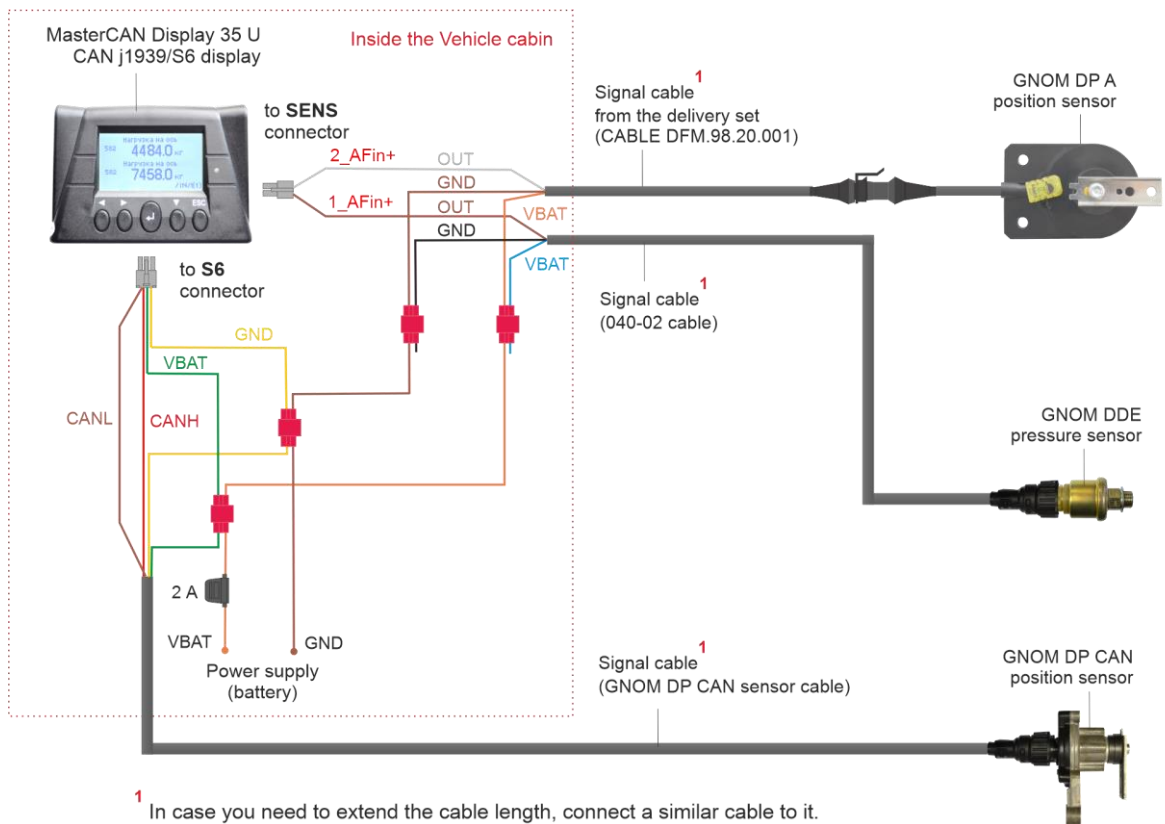

Figure 44 — Example of the connection diagram of two GNOM DP A and GNOM DDE analog sensors and one GNOM DP CAN digital sensor to MasterCAN Display 35 U

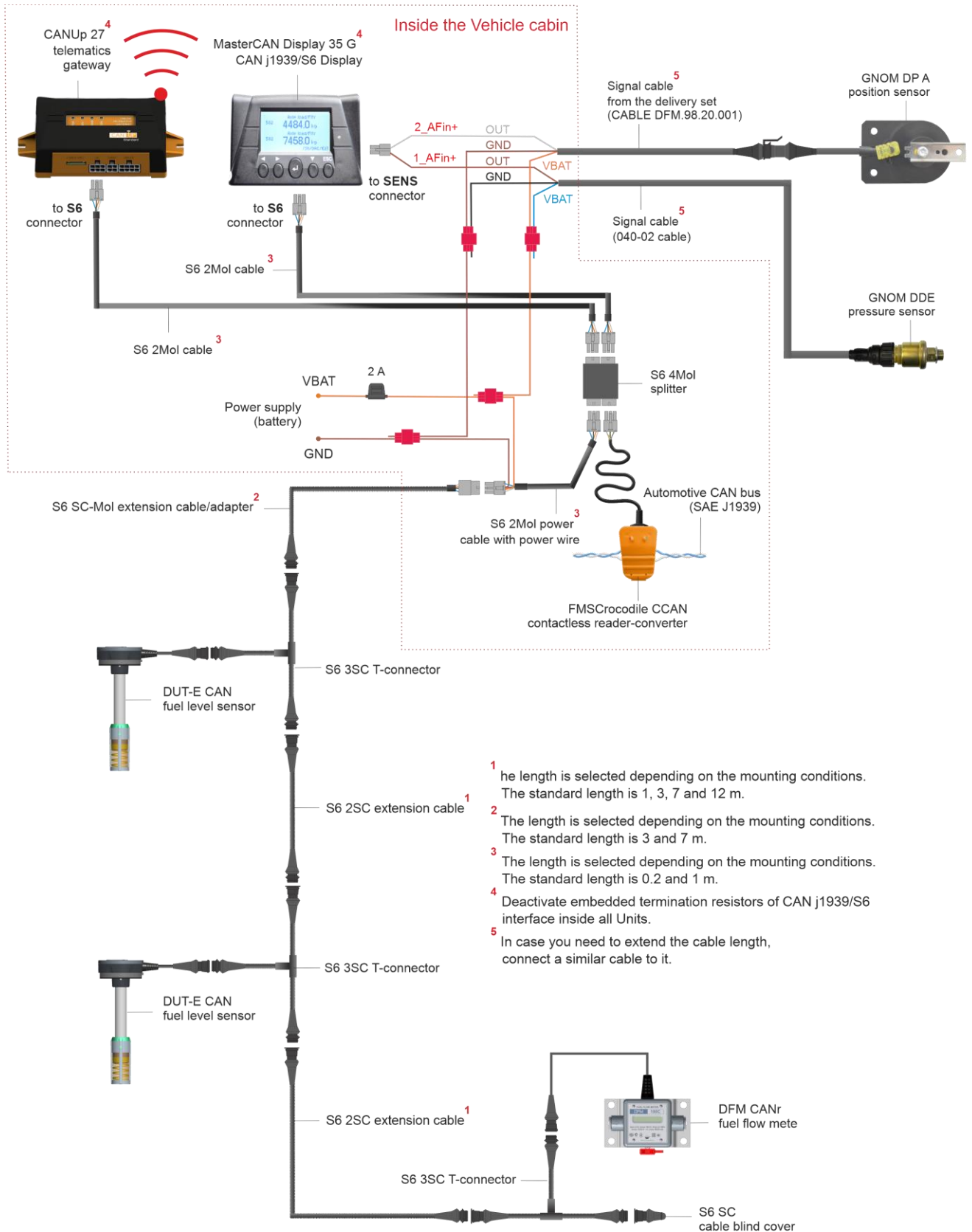
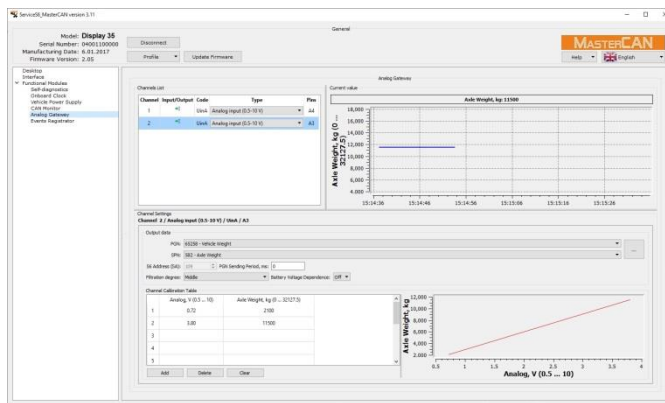

Figure 45 — Connection diagram of two GNOM sensors to MasterCAN Display 35 G together with Units and a standard Vehicle CAN bus

[MasterCAN Display 35 G](#) starts its operation from the moment the power supply is on. To monitor [Parameters](#) on the display, first, you need to configure it. To accomplish this, connect MasterCAN Display 35 to the personal computer (PC) with [S6 SK](#) adapter (purchased separately). Before you start your work with S6 SK, download the USB driver and Service S6 MasterCAN service software from <https://www.jv-technoton.com/> website, section [Software/Firmware](#) and install it on the PC.

To display data of axles loads using MasterCAN Display 35 G you must:

- 1) In the submenu of **Analog Gateway FM** service software (see figure 46 a):
 - Select and configure the display input channels for conversion of signals received from GNOM sensors into digital values ([SPN](#)).
 - Create and save calibration tables for each input channel of the display, with GNOM sensor connected.
- 2) In the submenu of **CAN Monitor FM** service software (see figure 46 b) configure the presentation of converted analog signals from GNOM sensors on the information screen of the display.



a) Analog Gateway FM

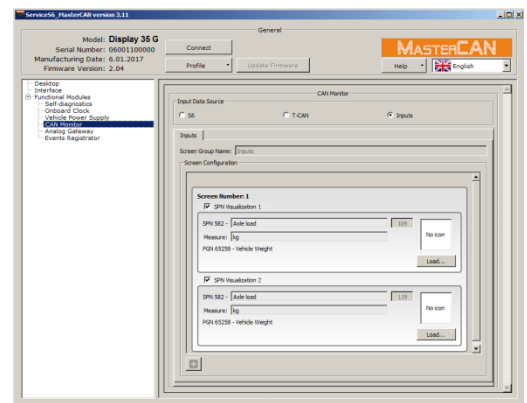

b) CAN Monitor FM

Figure 46 — MasterCAN Display 35 G settings windows in Service S6 MasterCAN software

A detailed description of MasterCAN Display 35 G and the procedure for its configuration with Service S6 MasterCAN software see in [CAN j1939/S6 Display 35 operation manual](#).

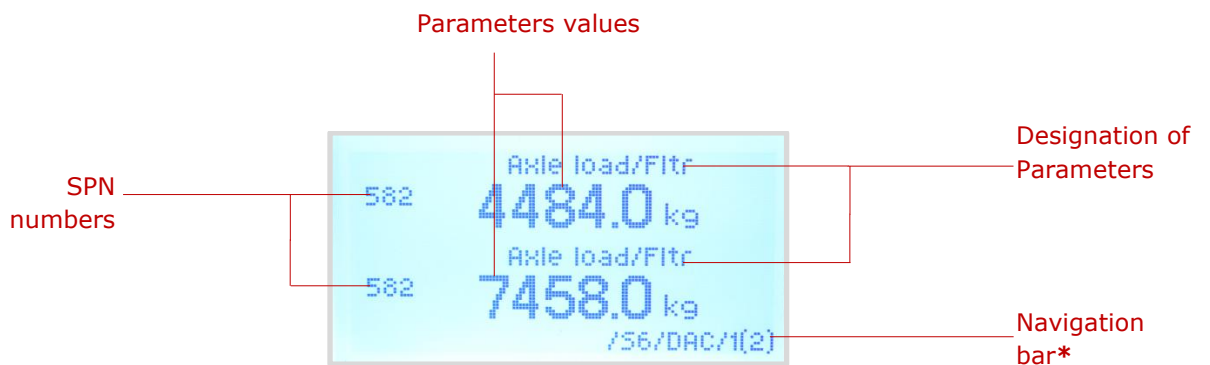

* Composition of the navigation bar: Source of input data/Group of screens/Screen number (Number of screens in the group)

Figure 47 — Example of presentation of the Vehicle axles load data on MasterCAN Display 35 G information screen

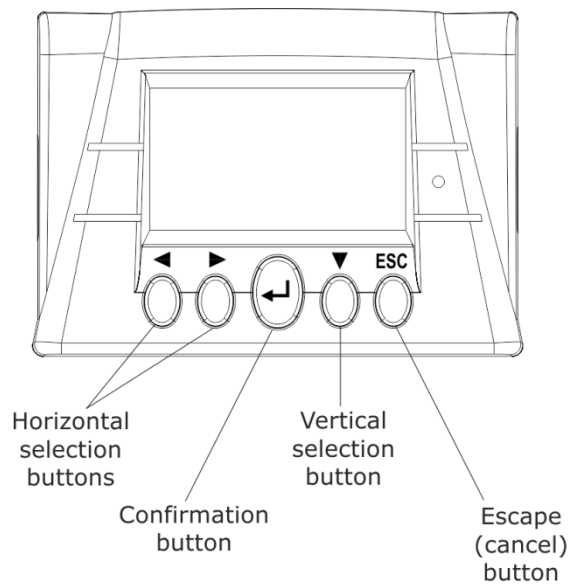

Example 1 Displaying DFM CAN/DFM D CAN data



Example 2 Switching to DUT-E CAN/DUT-E 2Bio CAN data

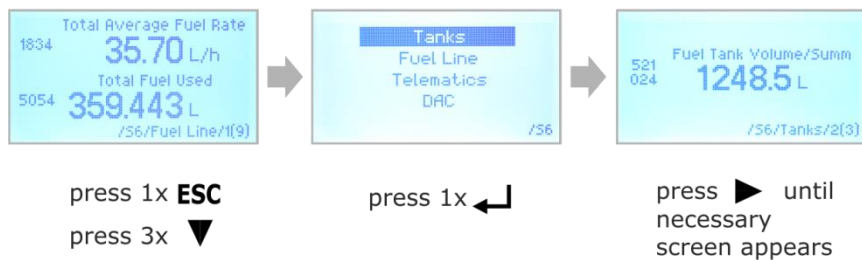

Example 3 Switching over to display converted signals from GNOM DP/GNOM DDE analog sensors



Figure 48 — Navigation keys and examples of switching between [MasterCAN Display 35 G](#) information screens

4 Packaging

[GNOM](#) delivery sets come in cardboard boxes of the following shape (see figure 49).



a) GNOM DDE



b) GNOM DP A

Figure 49 — Examples of sensor packaging

A label sticker containing information on the sensor name and model, serial number, date of manufacture, weight, Quality Control seal, QR code is stuck on GNOM pack (see figure 50).

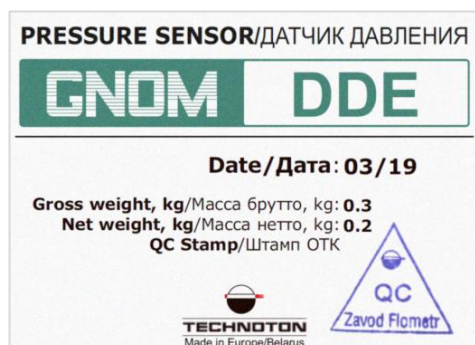

a) GNOM DDE



b) GNOM DP A

Figure 50 — Examples of packaging labels

Note — Label design and contents can be modified by the [Technoton](#).

5 Storage

[GNOM](#) is recommended to be stored in dry enclosed areas.

GNOM storage is allowed only in original packaging at temperature range from -50 to +40 °C and relative humidity up to 100 % at +25 °C.

Do not store GNOM in the same room with substances that cause metal corrosion and/or contain aggressive impurities.

GNOM shelf life must not exceed 24 months.

6 Transportation

Transportation of [GNOM](#) is recommended in closed transport that provides protection for GNOM from mechanical damage and precipitation.

When transporting by air, GNOM must be stored in heated pressurized compartments.

Air environment in transportation compartments should not contain acid, alkaline and other aggressive impurities.

Shipping containers with packed GNOM sensors should be sealed.

7 Utilization/re-cycling

[GNOM](#) does not contain harmful substances and ingredients that are dangerous to human health and environment during and after the end of life and recycling.

GNOM does not contain precious metals in amount that should be recorded.

Contacts

Distribution, technical support and service



sales@jv-technoton.com

support@jv-technoton.com



Annex A

Template of check test report

Report on axle load measurement accuracy test

Date _____

Vehicle type, model, registration number		
Tracking/displaying device model and serial number		
Axle load on the fully loaded Vehicle	According to scales m_{loaded} , tons	
Axle load on unloaded Vehicle	According to scales m_{scales} , tons	
	According to tracking device m_{track} , tons	
Accuracy error of axle load measurement of unloaded Vehicle	Absolute error $\Delta = m_{\text{track}} - m_{\text{scales}}$, tons	
	Normalized to axle load of loaded Vehicle $\delta = \frac{m_{\text{track}} - m_{\text{scales}}}{m_{\text{loaded}}} \cdot 100 \%$	
Axle load on loaded Vehicle	According to scales m_{scales} , tons	
	According to tracking device m_{track} , tons	
Accuracy error of axle load measurement of loaded Vehicle	Absolute error $\Delta = m_{\text{track}} - m_{\text{scales}}$, tons	
	Normalized to axle load of loaded Vehicle $\delta = \frac{m_{\text{track}} - m_{\text{scales}}}{m_{\text{loaded}}} \cdot 100 \%$	

Resume:

The results of axle load measurement **match/do not match** specifications.

Comments: _____

Representative of the CUSTOMER _____/_____

Representative of the CONTRACTOR _____/_____

Annex B

Cargo weight monitoring

Fleet operator can monitor carried cargo weight of Vehicles equipped with axle load sensors.

Weight = front axle load + rear bogie load

Axle load – is the load of the vehicle weight on the road surface exerted by wheels of one axle.

Weight of a two-axle Vehicle:

Weight = front axle load + rear axle load



Weight of a three-axle Vehicle:

Weight = front axle load + rear bogie load



Mounting sensor on each axle of the Vehicle is not always possible from technical point of view and is not economically feasible. Front axle load which is created by the weight of the driver's cabin and Vehicle engine is insignificant comparing with rear axle (rear bogie) load created by the weight of the Vehicle body (loading platform) and carried cargo. That is why a single sensor should be mounted on **the most loaded axle**.

The most loaded axle of two-axial Vehicles is the rear one. The rear bogie is most loaded on three-axial Vehicles (see figure B.1).

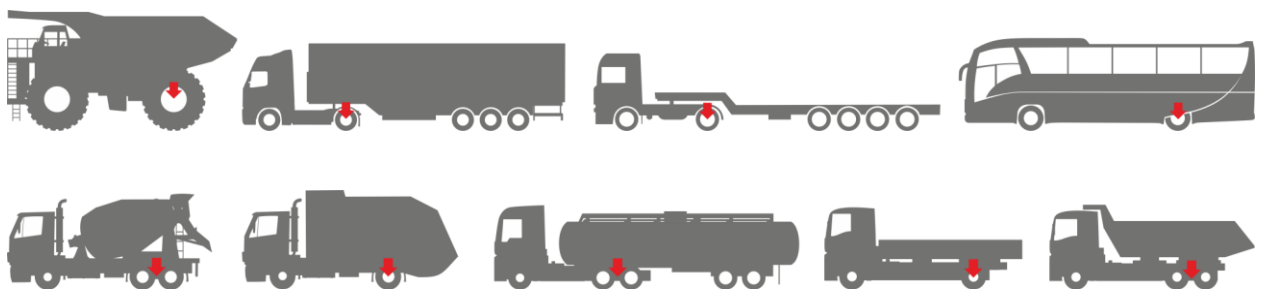

Figure B.1 – Most loaded axle of various Vehicles

Processing the axle load data the Server can estimate approximate cargo weight for different types of Vehicles (see tables B.1 and B.2).

Table B.1 — Cargo weight estimation for two-axial truck with three-axial semitrailer by truck rear axle load value

Axle load*, tons	Approximate cargo weight**, tons	Note
Less than 2	—	Wrong calibration
2.3		Semitrailer unhitched
4	0	Semitrailer hitched
6	9.0...9.5	
8	18...19	
10	27...28	
<p>* This chart compiled for MAZ 5440 truck. These characteristics may differ for other Vehicles.</p> <p>** If the Vehicle has isolated suspension circuits for left and right sides, then specified values will be valid only for a uniform distribution of load across the Vehicle body.</p>		

Table B.2 — Carried load weight estimation for three-axial dump truck by rear bogie load value

Rear bogie load, tons	Approximate cargo weight, tons
Less than 7	0
10	3.5...4.0
13	6.5...7.0
16	9.5...10.0
19	13.0...13.5
22	16.5...17.0
25	19.5...20.0

Performing calibration procedure with the loads of given weight (see [2.7](#)) provides much more accurate characteristics of axle (rear bogie) load versus carried load weight.

Annex C Diagrams of pre-set information screens for axle load monitor

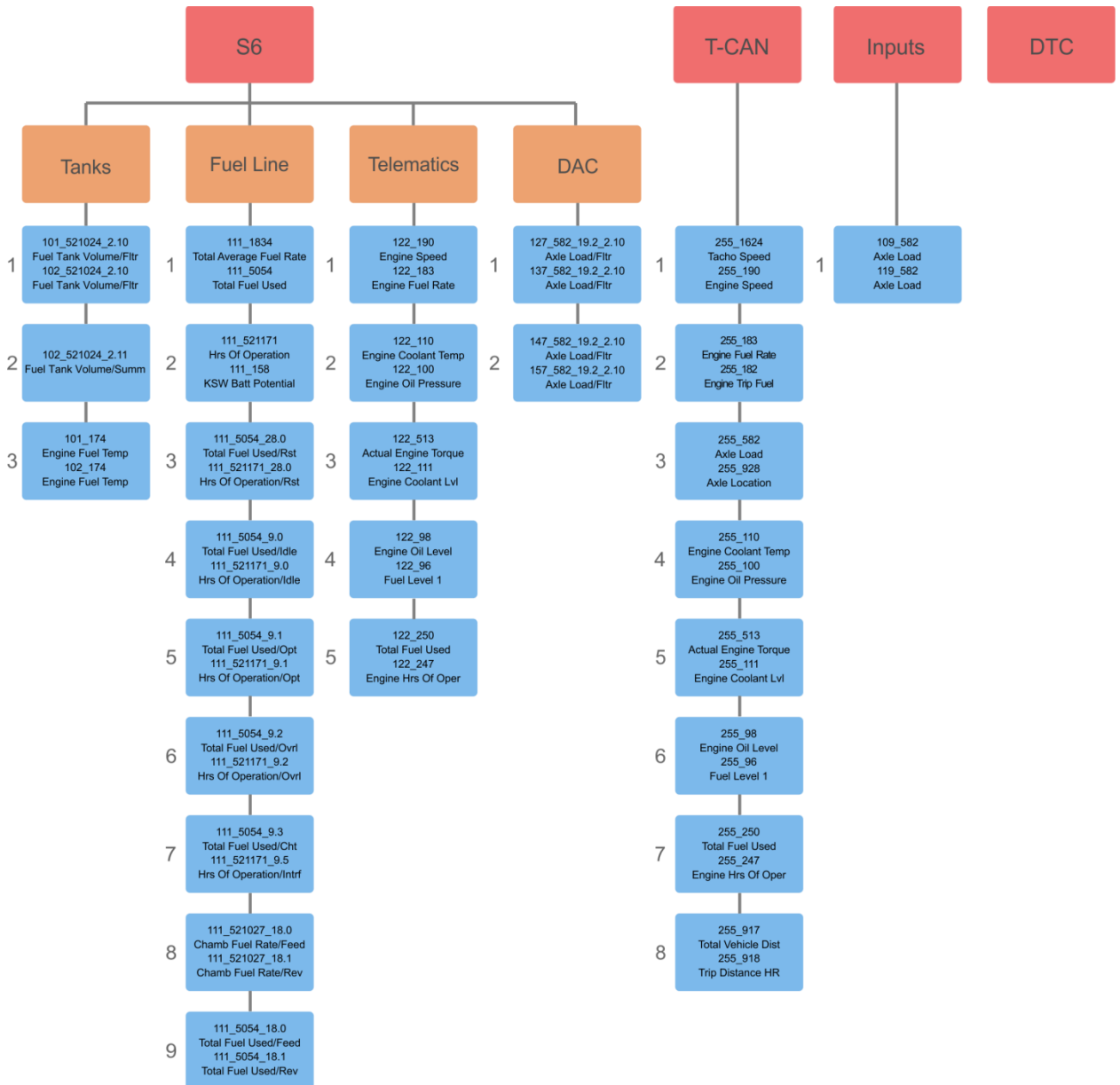

Notes

- 1 Pre-set screens of [MasterCAN Display 35 G](#) cannot be edited or deleted by the user.
- 2 In order to display a standard set of specified parameters, you need to connect equipment to MasterCAN Display 35 G, in accordance with table C.1.
- 3 In any of MasterCAN Display 35 G pre-set group of screens for sources of data from **S6** and **T-CAN** the user can add new screens to the maximum possible number of screens (10 pcs.).
- 4 The number of pre-set screens of MasterCAN Display 35 G and the content of the data displayed may be modified by the [Manufacturer](#) without prior notice.

Table C.1 — Equipment that should be connected to MasterCAN Display 35 G in order to display a standard set of parameters on pre-set screens

Designation of Equipment	Quantity, pcs.	Note
DFM CAN* / DFM D CAN Fuel flow meter	1	Connection using S6 Technology (to S6 connector).
DUT-E CAN / DUT-E 2Bio / DUT-E GSM Fuel level sensor	2	Connection using S6 Technology (to S6 connector) in any combination of fuel level sensors.
MasterCAN CC Vehicle data interface	1	To connect to standard Vehicle CAN-bus, you may use any of these Units. We recommend to connect MasterCAN CC to CAN-bus using CANCrocodile or CANCrocoLITE contactless readers.
FMSCrocodile CCAN Contactless reader-converter		
MasterCAN DAC2113 j1939 i/o module	2	Connection using S6 Technology (to S6 connector).
GNOM DP CAN Axle Load Sensor	1	Connection using S6 Technology (to S6 connector).
CANCrocodile / CANCrocoLITE** Contactless reader	1	Connection to S6 connector, operation in the sniffer mode.
GNOM DDE / GNOM DP A / GNOM DP Axle Load Sensor	2	Connection to SENS connector in any combination of models and types of sensors used.
DUT-E AF Fuel level sensor		
<p>* In case of connection of one-chamber flow meters, SPN values that can be displayed only by differential flow meters are not shown.</p> <p>** In case of CANCrocodile/CANCrocoLITE connection, data display is only possible on the screens for T-CAN source of input data. In this case, simultaneous connection of other Units to S6 connector is not allowed.</p>		

Annex D

Recommendations on the equipment calibration, connection and configuration, when using GNOM sensors

1) Recommendations regarding the calibration process

To monitor the Vehicle axle load (irrespective of the number of GNOM sensors used), you need to conduct the calibration procedure individually for each axle. For this purpose, the Vehicle axle weighing scales are used; only one axle of the [Vehicle](#) can be placed on the scale (see [figure 36 a](#)). The calibration table should contain at least two points – “Vehicle completely unloaded” and “Vehicle maximally loaded”.

Note: Weights measured with Vehicle weighing scales during the individual calibration of each axle should not be confused with values of the Vehicle cargo weight.

Table D.1 – Example of an axle load calibration table

Output voltage of GNOM sensor, V	Axle load, kg
1.545	4012
3.214	12854

To monitor the Vehicle weight, you need to conduct the calibration procedure by weighing the entire Vehicle, with placing the entire Vehicle on the platform of the special Vehicle weighing scale (see [figure 36 b](#)).

In case the precise cargo weight is not known, first, you must measure the GNOM output signal for the completely unloaded Vehicle, then – for the maximally loaded Vehicle.

You should load the Vehicle following health and safety rules, as well as general regulations regarding loading/unloading, positioning and fixing cargo that are established at a particular road transport company.

E.g., if the cargo is discrete, the Vehicle loading procedure is carried out in the “front-back” order, with even spreading of the cargo along the whole platform.

Experience shows that the most precise weighing results can be obtained in case of using bulk cargo or fluid cargo in the process of calibration.

Table D.2 – Example of a truck axle calibration table for monitoring the cargo weight

Output voltage of GNOM sensor, V	Cargo weight, kg
1.547	0
3.214	10855

To enhance the accuracy of cargo weighing, we recommend to use two GNOM sensors. One GNOM sensor is to be mounted on the rear axle (bogie), while the other – on the axle (bogie) of the semitrailer. For the truck Vehicle, GNOM sensors should be mounted on the front and rear axles, the calibration process for each of the monitored axles being identical.

Table D.3 — Example of the calibration table for the semitrailer axle for monitoring the cargo weight

Output voltage of GNOM sensor, V	Cargo weight, kg
1.149	0
3.015	10855

To reduce the monitored cargo weight value **M** dependence on even spreading the cargo along the platform to the minimum, it should be calculated on the [Telematics server](#) according to the formula (D.1).

$$M = (M1 + M2) / 2 \tag{D.1}$$

where **M1** – cargo weight measured for the front Vehicle axle;

M2 – cargo weight measured for the rear Vehicle axle.

Notes — If during defining the weight values the weight of empty Vehicle is deducted, then **M** is the cargo weight. If it is not deducted, **M** is the weight of the loaded [Vehicle](#).

2) Recommended schemes of the equipment connection

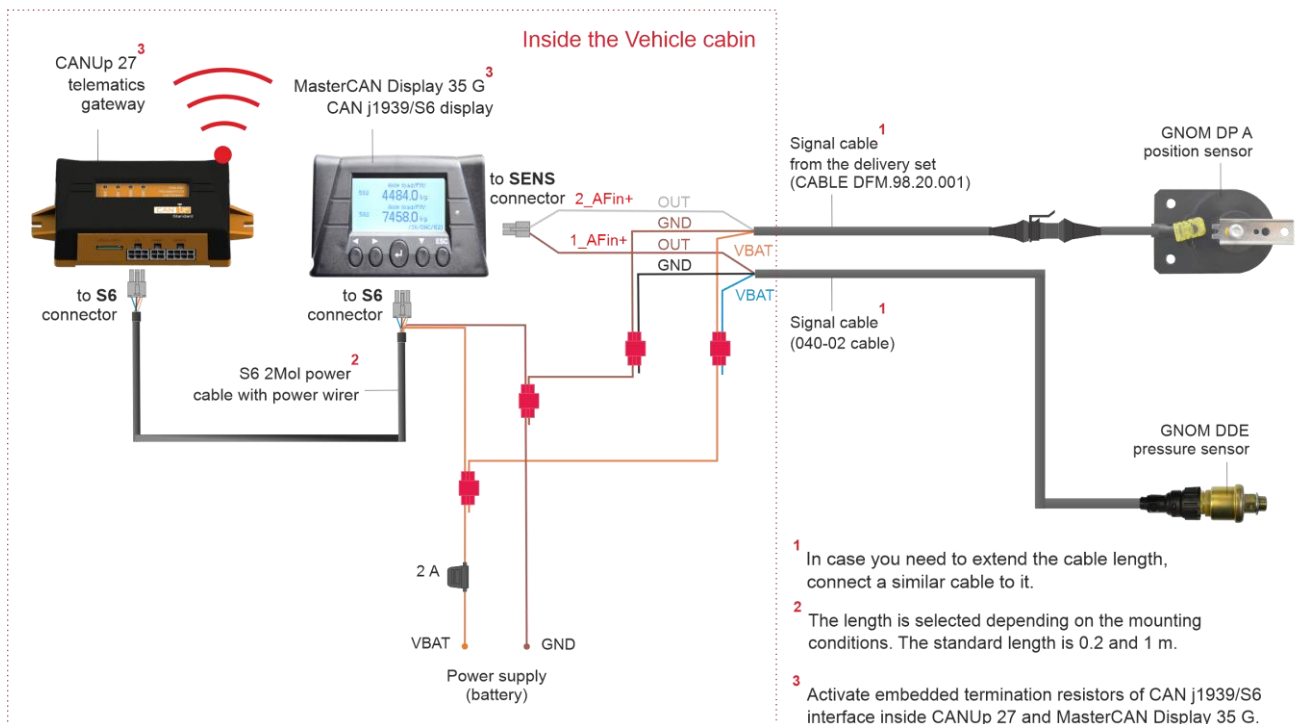

Figure D.1 — Typical scheme of the equipment connection for monitoring the axle load for a road train with a non-interchangeable semitrailer (see [figure 5](#))

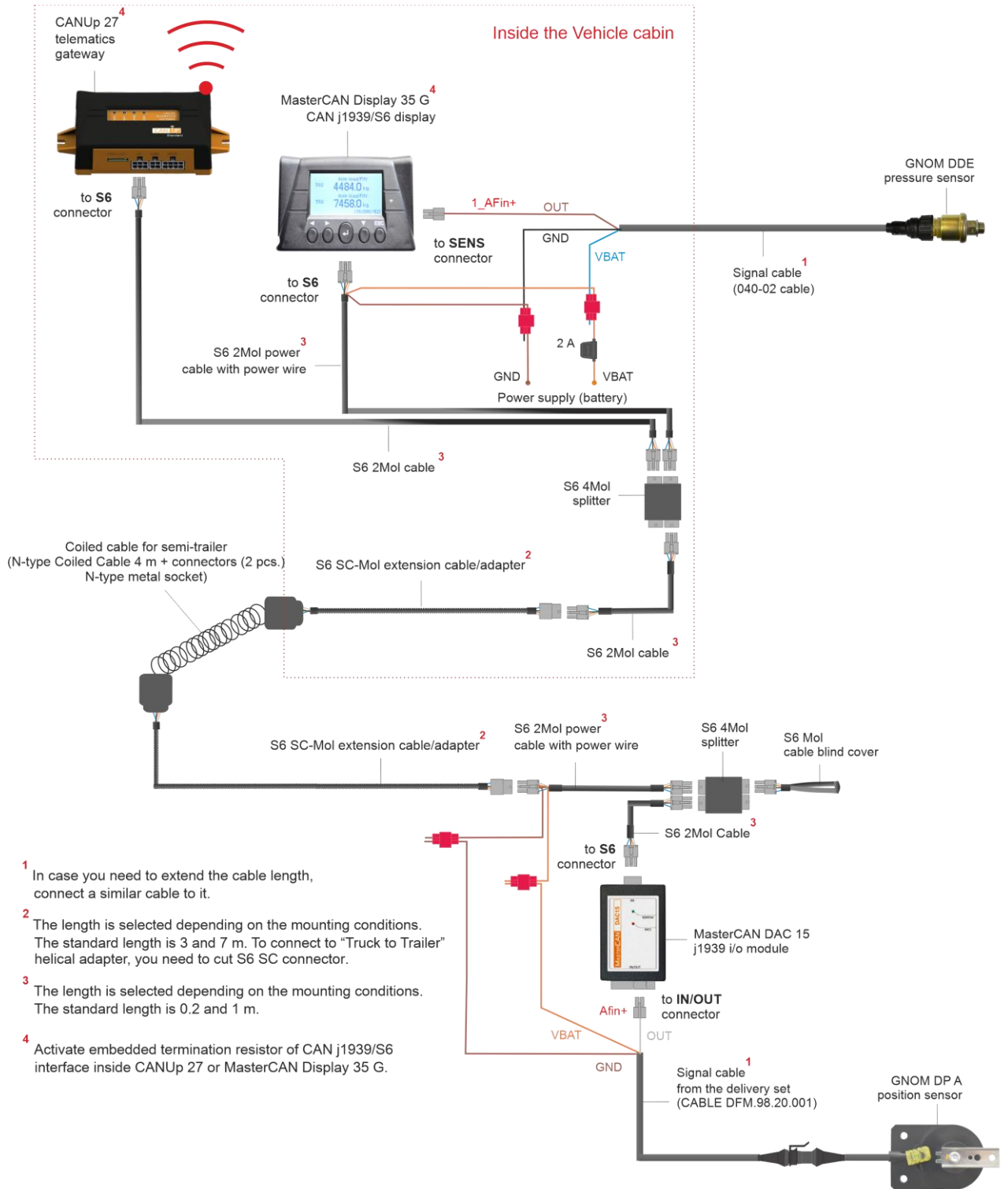

Figure D.2 — Typical scheme of the equipment connection for monitoring the axle load for a road train with a replaceable semitrailer (see [figure 6](#))

3) Recommendations on the equipment configuration

When using [MasterCAN Display 35](#) display of [CAN j1939/S6](#) bus for conversion of two analog signals from two GNOM sensors into digital values ([SPN](#)), you need to create a calibration table individually for each of the sensors and save it in the display memory using Service S6 MasterCAN service software (see figure D.3).

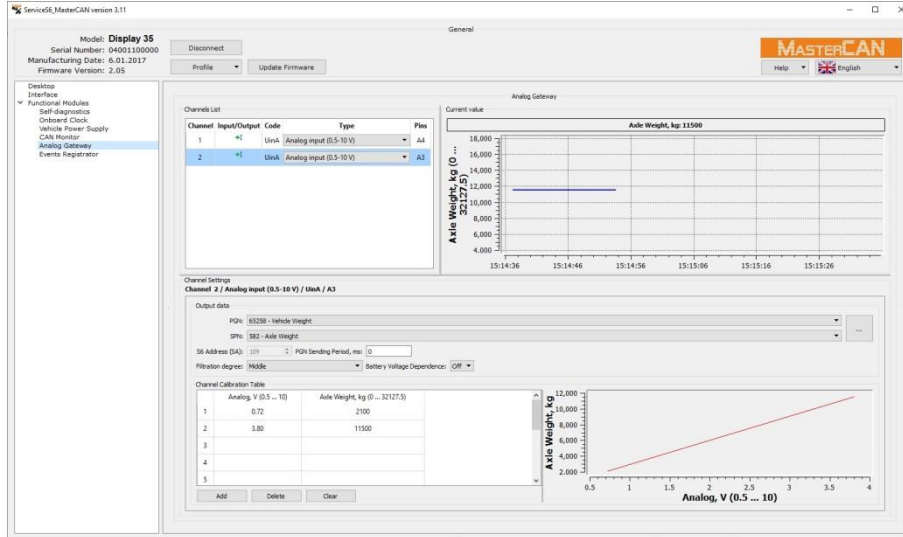

Figure D.3 – Creation of calibration tables of GNOM sensors using Service S6 MasterCAN software

For simultaneous correct operation of the two GNOM sensors, specify their network addresses (SA) 109 and 129 in the settings of inputs.

In order to obtain the readings of GNOM output signal in volts, we recommend to select for temporary use the following output data in the settings of each analog input: [PGN 64777](#) (High Resolution Fuel Consumption (Liquid)) and [SPN 5054](#) (High Resolution Engine Total Fuel Used). In this case, current values of GNOM output signal in volts are displayed in the graph and in the line of the current value of total fuel consumption. Write down the data of the calibration tables points in the notepad and replace the output data of each analog input with raw data: [PGN 65258](#) (Vehicle Weight) and [SPN 582](#) (Axle Weight). Then, enter the calibration table points manually and save the profile in the [Unit](#) (see figure D.4).

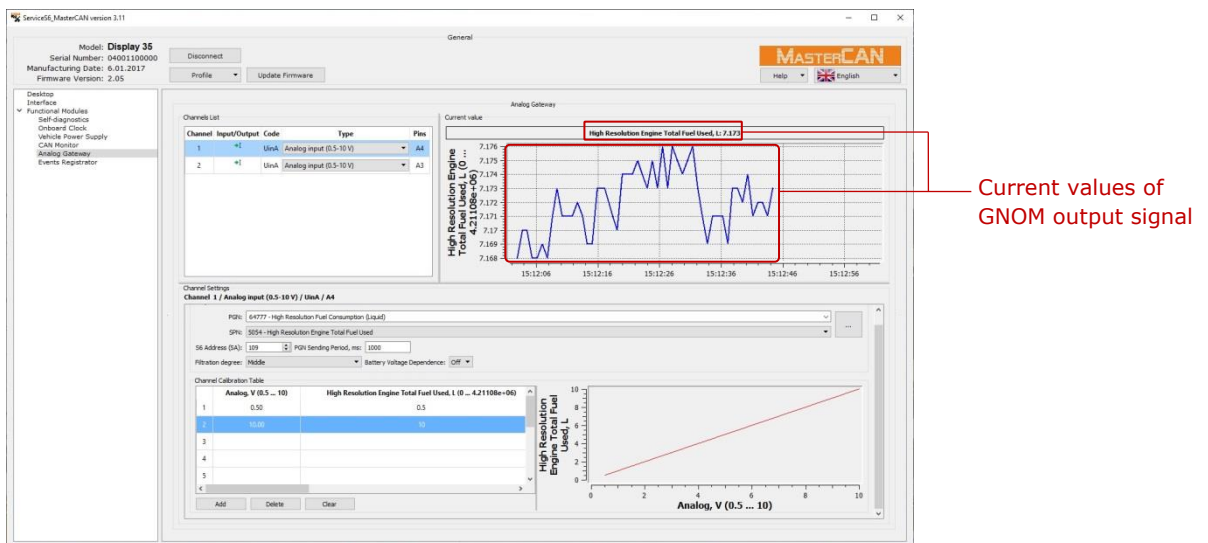

Figure D.4 – Getting readings of the output signal of GNOM connected to MasterCAN Display 35 with Service S6 MasterCAN software

In case of using MasterCAN DAC 15 digital to analog converter (i/o module) for conversion of GNOM sensor analog signal into digital values (**SPN**), you are to create a calibration table for the connected sensor and save it in the converter memory.

To configure the input, you are to select the following output data of **PGN 62985** (Axle Load Control Parameters) and **SPN 582** (Axle Weight /Rear axle).

In the process of calibration current values of GNOM output voltage are displayed on the button below the calibration table (see figure D.5).

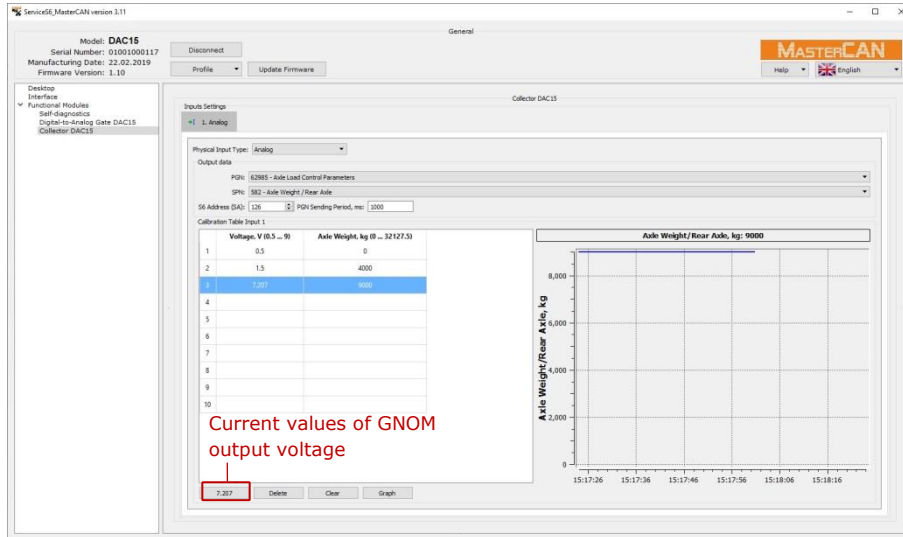

Figure D.5 – Getting readings of the output signal of GNOM connected to MasterCAN DAC 15 with Service S6 MasterCAN software

In case the sensor is connected directly to the analog input of the **Telematics terminal** of any manufacturer, we recommend the following:

In case the Terminal service software displays the current value of GNOM output voltage, first, write down the created calibration table (Voltage, V/ Axle load, kg) into the notepad. You may enter it manually on the **Server** later on to recalculate values of the current output signal into the axle load data.

If the current value of GNOM output voltage is not displayed in the Terminal service software, they can be viewed in raw parameters directly on the Server.

Annex E

Videography

1) Video “GNOM DP S7 axle load sensors, diving basics”

A common thing for Technoton technicians is to conduct "survival" experiments on our telematics hardware. We conducted an experiment on a new axle load sensor GNOM DP S7. In the morning we had put the sensor into the water, and in the afternoon get the sensor out of the water and checked out water impermeability — after 7 hours spent in the water, GNOM DP S7 worked as if nothing had happened! The sensor still showed the correct angles and temperature.



<https://www.youtube.com/watch?v=27VpRVeGpIU>

2) Video “GNOM DP S7 axle load sensor: game of ice”

We conducted another experiment: sent the sensor for 3 days to the freezer! When GNOM S7 sensor was pulled out, it showed -23 °C, and continued to display correct data values.



<https://www.youtube.com/watch?v=hRnEOcNWJIE>

3) Video “Axle load monitoring for leaf spring suspension. Demo stand”



<https://www.youtube.com/watch?v=ZEPp5FCZcBY>

4) Video “Axle load monitoring for air suspension. Demo stand”



<https://www.youtube.com/watch?v=eUsBp1qRhwY>

5) Animation “GNOM DP position sensors. Mounting and application”.

The animation shows sensor mounting schemes for biaxial and threeaxial Vehicles as well as instance of the diagrams built on sensor data in Vehicle monitoring system.



<https://www.youtube.com/watch?v=9njffVByJog>

6) Other [Technoton](#) videos are on the YouTube channel which is regularly updated:



<https://www.youtube.com/channel/UCq7EF3DHrgl7fOWB2yysR-A>