

GNOM

Axle load sensors



TECHNOTON

ADVANCED VEHICLE TELEMATICS

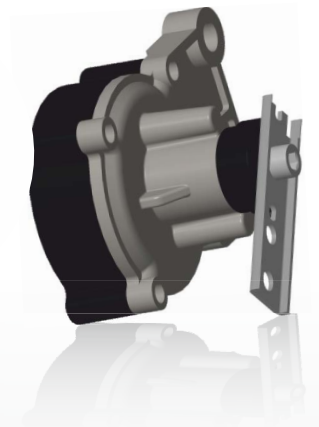

Belarus, Minsk www.jv-technoton.com

What is axle load?

Axle load – total weight to which a surface of road exposed through wheels of a given axle.



Weight of two-axle vehicle:
Weight= front axle load + rear axle load



Weight of three-axle vehicle:
Weight= front axle load + rear bogie load

Vehicle suspension types



Leaf spring (mechanical) suspension system

Slender arc-shaped length of spring steel of rectangular cross-section. Center of the arc is fixed to the axle, loops at the ends of the arc – to chassis.

GNOM DP and **GNOM DP S7** sensors are used.



Pneumatic (air-pressure) suspension system

Operation of air suspension is ensured by air cylinders with compressed air. Air pressure is created by a compressor.

GNOM DDE and **GNOM DDE S7** are used.

Tasks #1



Driver supervision and elimination of unauthorized cargo. Sensors help fleet owners to stay informed about unauthorized cargo loading and unloading.



Trailer load optimization. Data from sensors is used for detecting trailer overload and underload, allows decreasing suspension wear out and improving efficiency of trailer operation.

Tasks #2

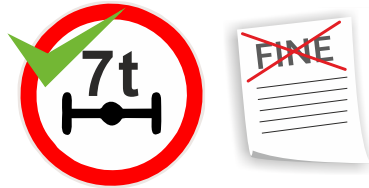

Avoiding fines for exceeding maximum axle load. Sensors provide info on current axle load, helping to monitor total vehicle weight and eliminate fines for excess load per axle.

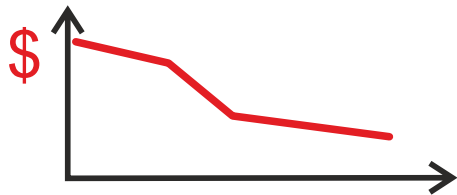

Decreasing costs for suspension maintenance. If vehicle is loaded optimally, suspension lasts longer comparing to overloaded one – less maintenance is needed and repairment costs are reduced.

Example of axle load monitoring system



GNOM axle load sensors are used in vehicle telematics systems for measuring load per axle and total cargo/vehicle weight.

GNOM Axle load sensors

Sensors with signal cable



GNOM DDE



GNOM DP, GNOM DP CAN

GNOM Axle load sensors
GNOM DP/ Structure

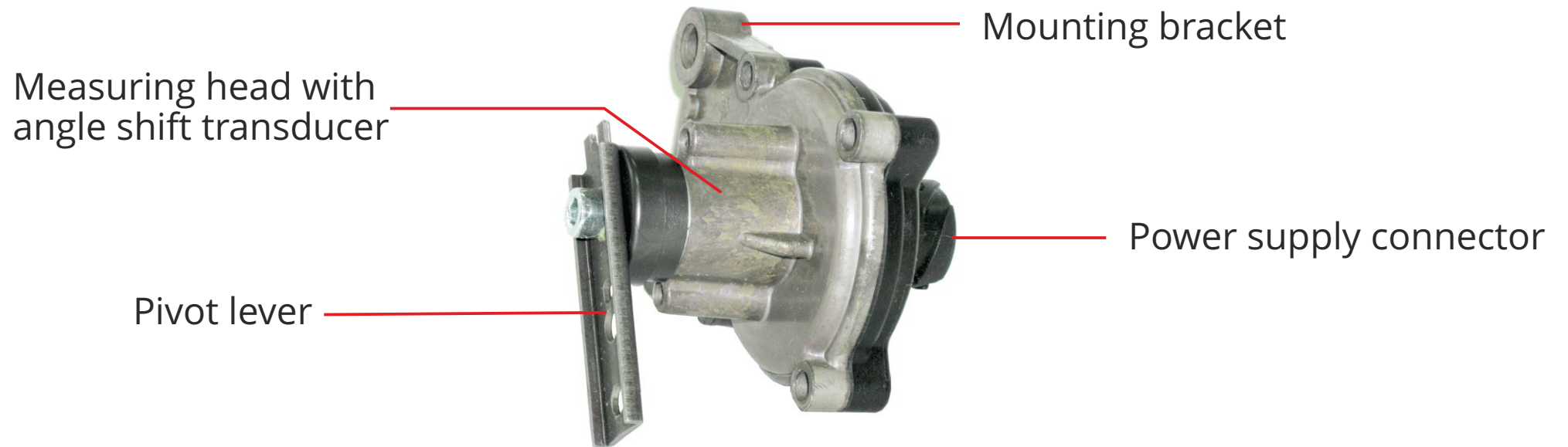

The output signal:

- analog (voltage), GNOM DP model
- CAN j1939 interface, GNOM DP CAN model

GNOM DP/ Operation principle

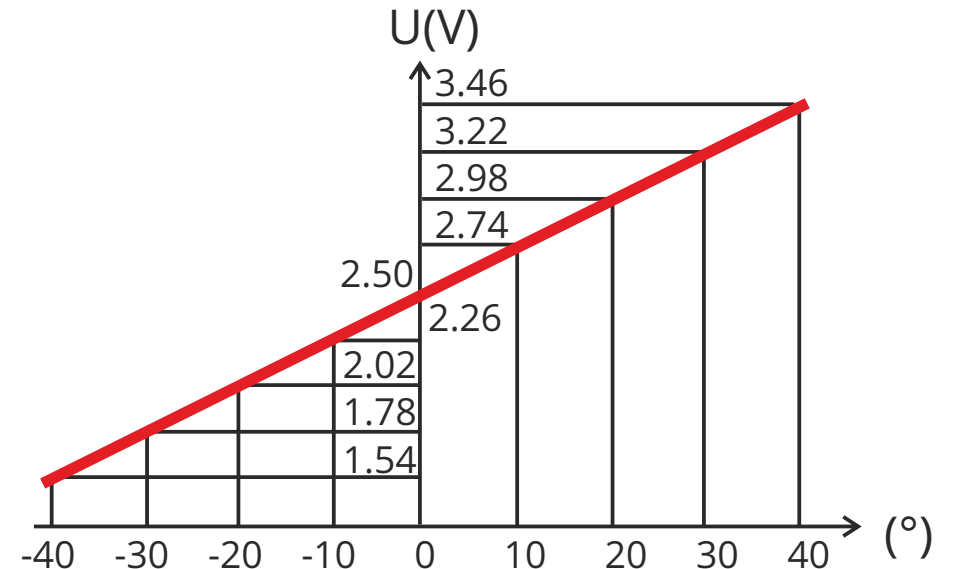
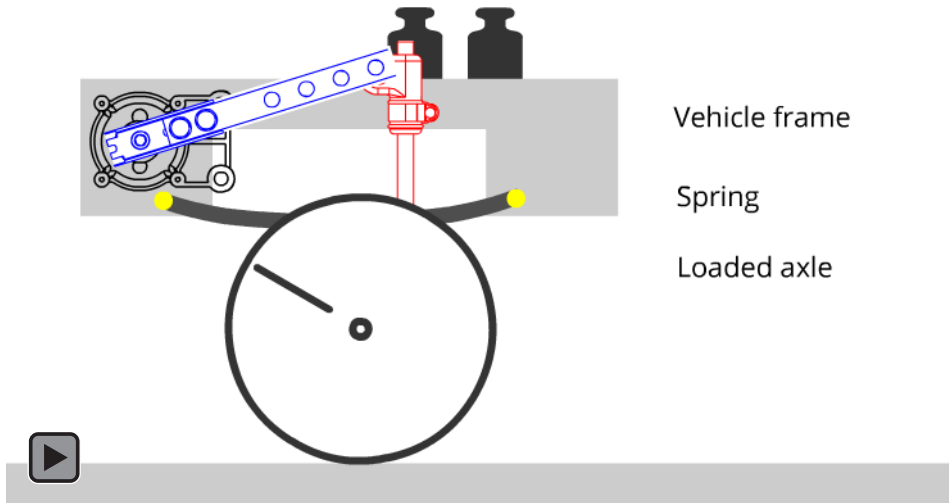

Sensor's pivot lever is attached to an axle using special mounting kit, while sensor's body is fixed to cargo bed or vehicle frame. When a cargo is placed in, vehicle's frame goes down and shifts the pivot lever – that shift generates output voltage signal of GNOM DP.

GNOM DP/ Features

- ✓ The sensor is installed on rear axle/bogie of a truck or semi-trailer with leaf spring suspension.
- ✓ It measures axle shift when axle load is changing.
- ✓ The sensors can be connected to any GPS-tracker with voltage input.

Supply voltage range	8...32 V
Output voltage range – GNOM DP model	1.54...3.46 V
Interface – GNOM DP CAN model	CAN j1939

GNOM DP/ Mounting kit

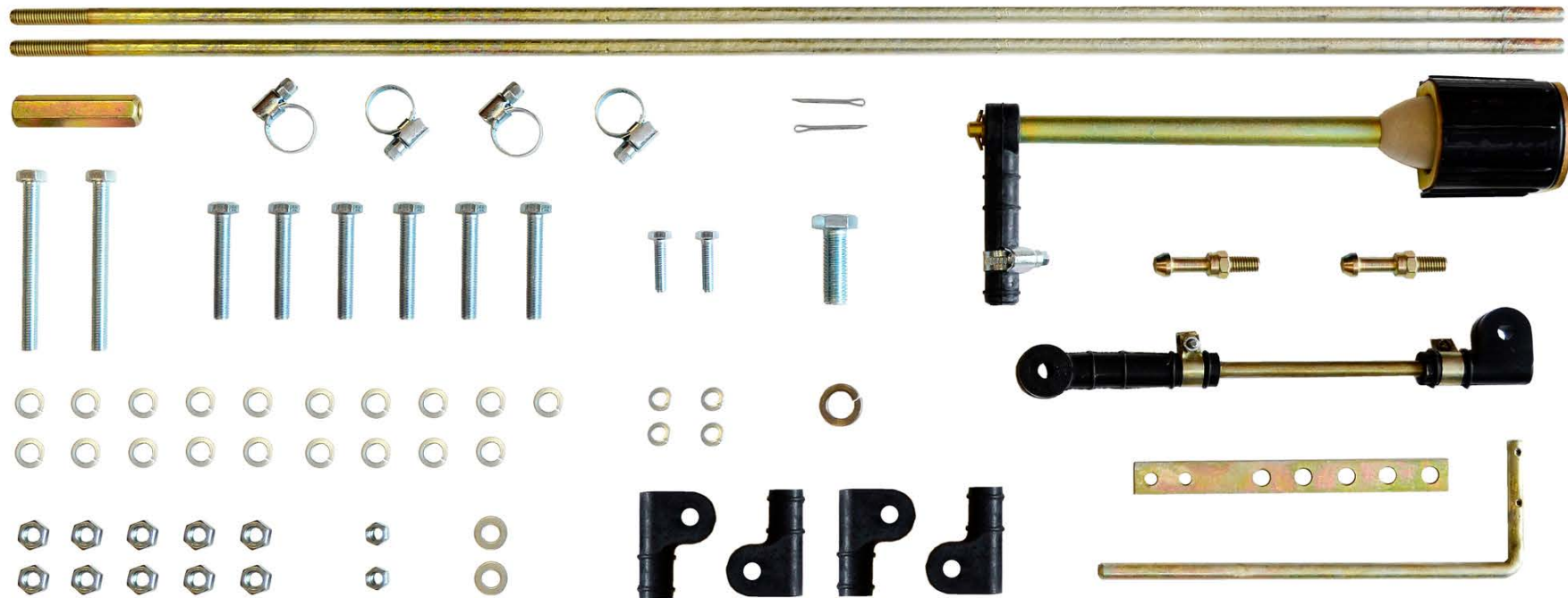

Mounting kit specially designed by Technoton ensures durable mounting of the sensor to a vehicle

GNOM DP/ Data example – garbage truck

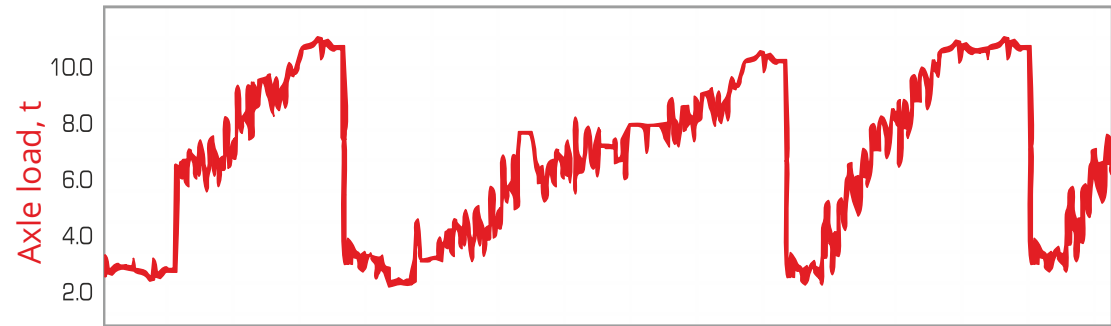

Axle load – 4,5 t	Cargo weight – 5,3 t
Loading during a trip – 102	Unloading during a trip – 3

GNOM DDE/ Structure

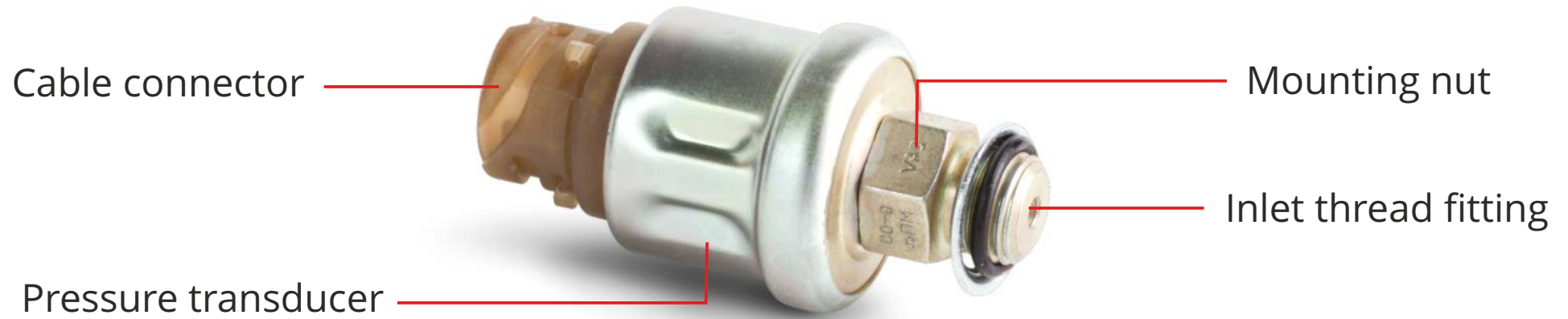

The output signal is analog (voltage).

GNOM DDE/ Operation principle

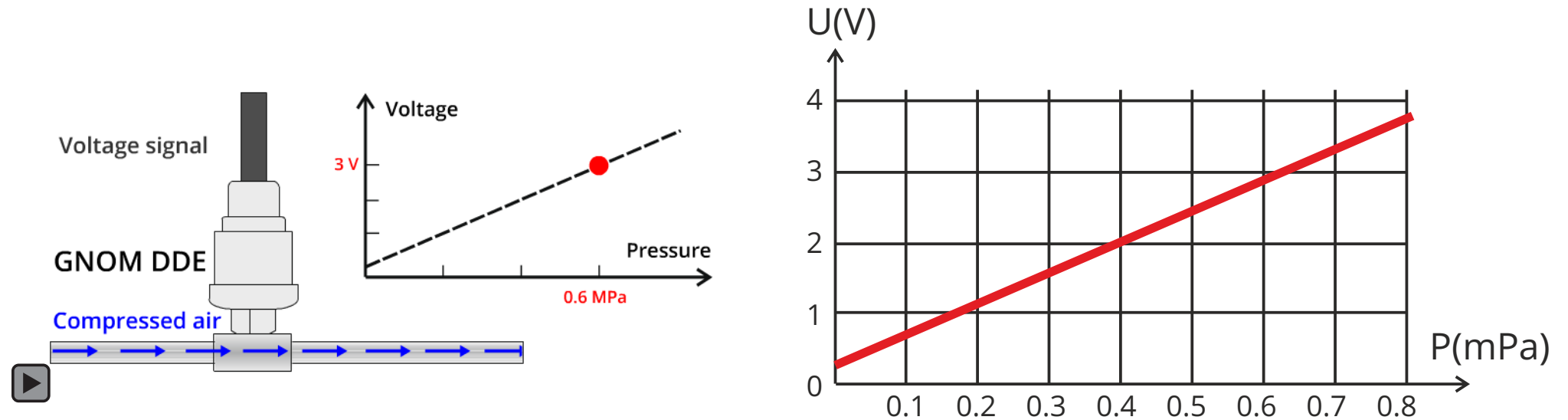

Operating principle of the sensors is based on measuring compressed air pressure and generating stabilized output signal. Output signal voltage is directly proportional to the pressure of compressed air in vehicle's suspension system.

GNOM DDE/ Features

- ✓ Installed in air cylinder or compressed air line of suspension.
- ✓ Measures pressure of compressed air in pneumatic system.
- ✓ Can be connected to any GPS-tracker with voltage input.
- ✓ Output signal is stabilized and does not dependent on power supply voltage.

Inlet pressure	0...0.8 MPa
Supply voltage	8...32 V
Output voltage range	0.25...3.80 V

GNOM DDE/ Data example – freight truck

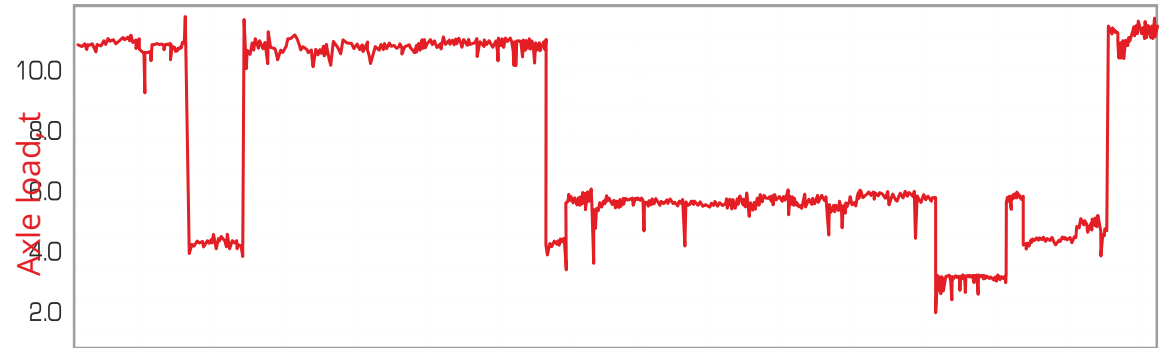
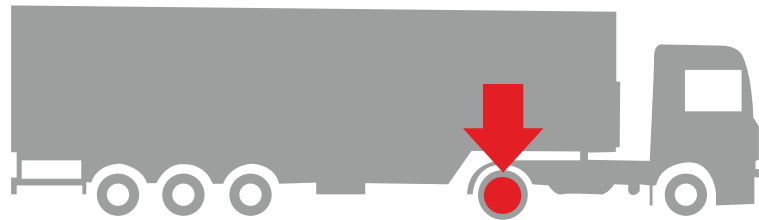

Axle load – 6,0 t	Cargo weight – 9,5 t
Loading during a trip – 3	Unloading during a trip – 2

GNOM Axle load sensors



GNOM DP и GNOM DDE – compatibility with terminals



GNOM DP and GNOM DDE can send signal to any terminal unit equipped with 0 – 5V analog input.

GNOM Axle load sensors



Wireless sensors. S7 Technology



GNOM S7 DDE

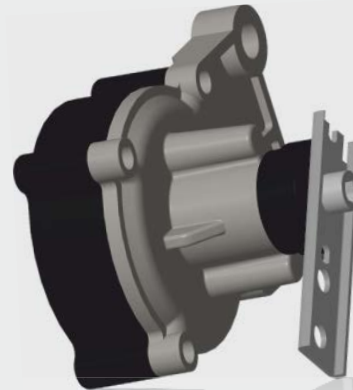

GNOM S7 DP



S7 Technology

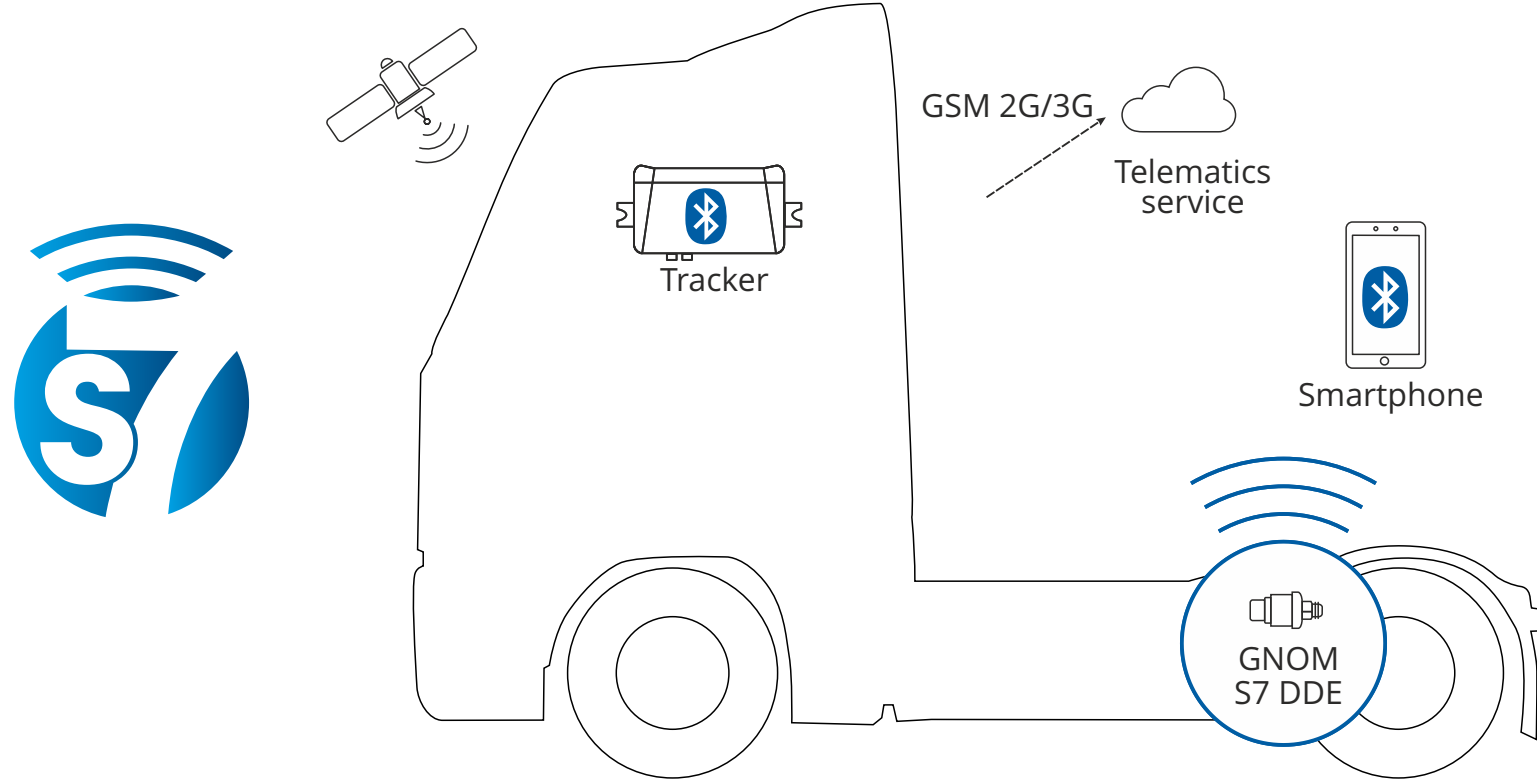

Technology for wireless data collection from autonomous sensors used in industrial and automotive telematics systems.

GNOM S7 DP/ Structure

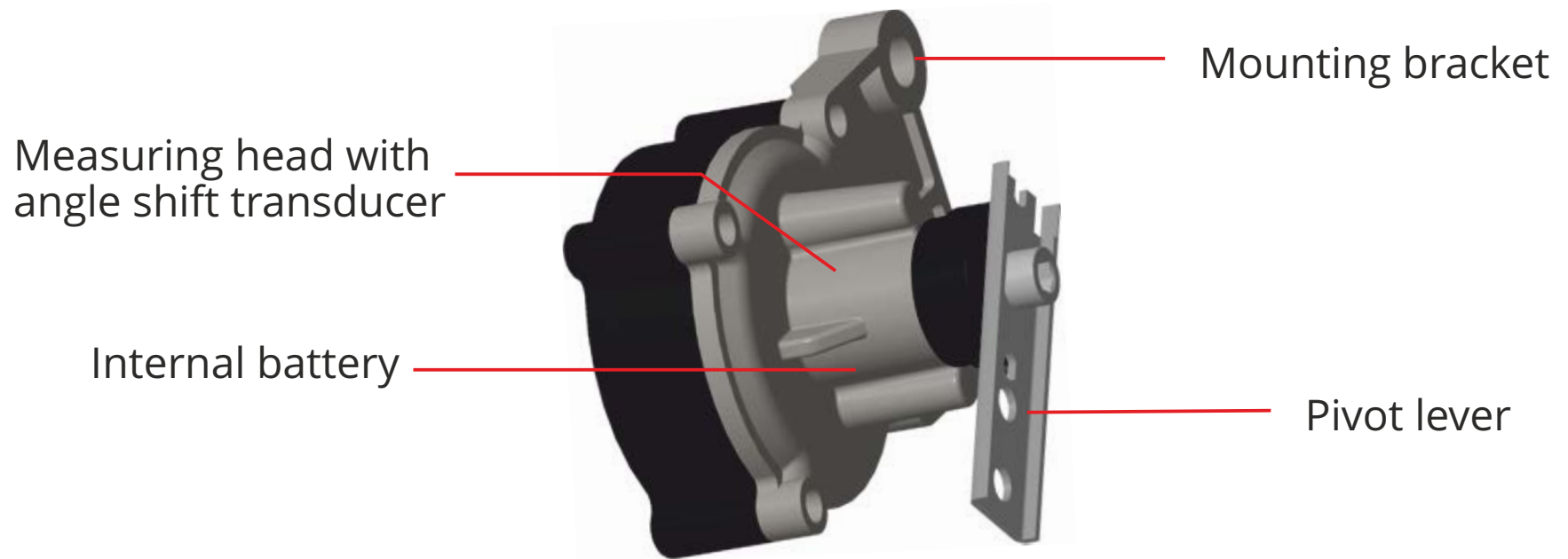

Wireless data transfer via BLE (Bluetooth low energy).
Data transmission protocol using S7 Technology.

GNOM S7 DP/ Features

- ✓ The sensors is installed on rear axle/bogie of a truck or semi-trailer with leaf spring suspension.
- ✓ It measures axle shift when axle load is changing.
- ✓ Wireless data transfer to several Receivers simultaneously over Bluetooth 4.X



Estimated lifetime of the sensor (battery life)	5 years
Data transfer distance	10 – 20 m

GNOM S7 DDE/ Structure



Wireless data transfer via BLE (Bluetooth low energy).
Data transmission protocol using S7 Technology.

GNOM S7 DDE/ Features

- ✓ Installed in air cylinder or compress air line of suspension.
- ✓ Measures pressure of compressed air in pneumatic system.
- ✓ Wireless data transfer to several Receiver simultaneously over Bluetooth 4.X



Inlet pressure	0.1...1.4 MPa
Estimated lifetime of the sensor (battery life)	5 years
Data transfer distance	10 – 20 m

GNOM Axle load sensors



GNOM S7 DP и GNOM S7 DDE – compatibility with terminals



Up-to-date list is here: www.jv-technoton.com/compatibility/

Service S7 GNOM mobile app

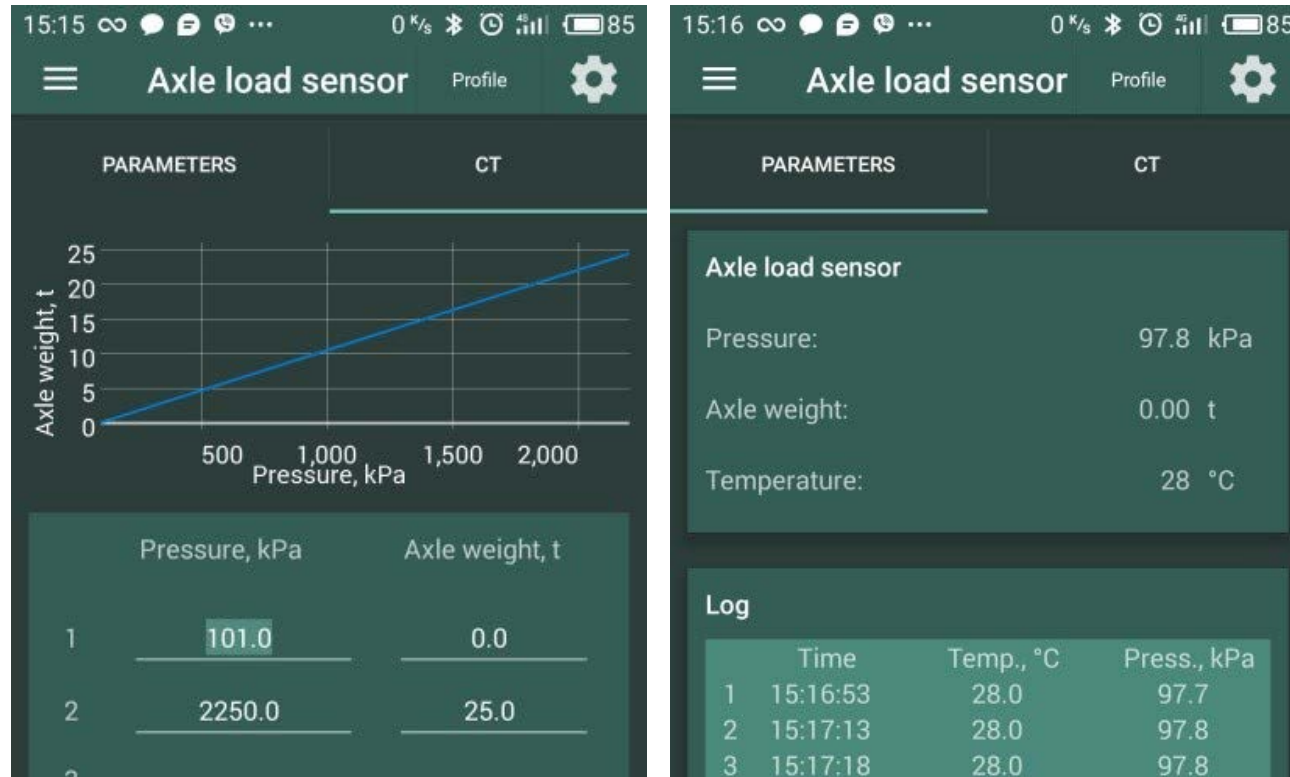

Allows driver and chief mechanic to get sensors' data in real time without a server.

GNOM S7 DP and GNOM S7 DDE – sending data to Receiver

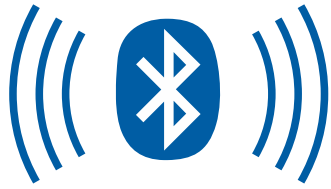

- ✓ Configuration profiles for GNOM DP S7 and GNOM DDE S7 and calibration tables are done on Receivers' side. Sensors' factory settings can not be affected.
- ✓ If a smartphone or tablet is used as data Receiver, Service S7 GNOM app should be downloaded from Google Play and installed to a device.
- ✓ Configuration profiles are saved only in Receivers and not in the sensors – not possible to affect configurations intentionally or accidentally.

Summary

GNOM sensors are:

- ✓ used in telematics systems for vehicle weight monitoring and preventing axle overload;
- ✓ helping fleet owners to avoid fines for exceeding load per axle and extra repair costs;
- ✓ used for vehicles and trailers with mechanic and pneumatic suspension systems.

Any GPS tracker with voltage input up to 5V can be used with GNOM sensors.

Wireless GNOM with Bluetooth 4.1 can send data both to telematics unit and to driver's smartphone.

Specially designed by Technoton mounting kit allows durable installation on axle and frame.

Learn more

Official web-pages



www.jv-technoton.com

More about S6 Technology



rd-technoton.com

More about IoT Burger Technology



rd-technoton.com

Document center



www.docs.jv-technoton.com

YouTube channel



[/c/technotonen](https://www.youtube.com/c/technotonen)

Follow us in social media



[/company/technoton](https://www.linkedin.com/company/technoton)



[/technoton](https://www.facebook.com/technoton)